

# DSP280

## Dual socket 2nd generation Intel Quad Core i7 Multiprocessor

### Features

- Dual Intel Core i7 Quad Core Processors
  - Intel® Advanced Vector Extensions™ (AVX)
  - Intel® Hyper-Threading Technology
  - Intel® HD Graphics 3000 with 3D & OpenGL
  - Intel® Turbo Boost 2.0 at up to 3GHz
  - Trusted Platform Module (TPM)
- Two CPU sub-systems each with:
  - 6Mbytes shared L3 Cache
  - 8GigaBytes DDR3 SDRAM (16GB total)
  - Dual Port RDMA NIC-10GE & DDR Infiniband
- QM67 IO Hub
  - 4MB SPI FLASH plus recovery BANC FLASH
  - 512KB MRAM NV memory for mission data
  - 8GigaBytes NAND FLASH Disk
  - HDMI/DVI Display port
  - 2 x USB 2.0 ports
  - SATA 3.0 interface
  - 2 x RS232/422/485 Serial ports
  - 8 x GPIO
  - PS2 Keyboard & mouse
- 6U OpenVPX VITA65 Payload profile with:
  - Data Plane: 10GE/Infiniband RDMA NICs
  - Expansion Plane: Gen 2 PCIe Switch with DMA
  - Control Plane: 2 x GbE ports per node

DSP280 is the world's first fully rugged 6U OpenVPX multiprocessor to bring mainstream High Performance Computing (HPC) to deployed defence and aerospace applications. GE Intelligent Platforms has harnessed Intel's latest Quad Core i7 32nm embedded chip set to create the ideal COTS solution to meet the real-time performance requirements of extended intelligence, surveillance and reconnaissance (ISR) mission profiles across a wide range of deployed platforms including both manned and un-manned airborne, ground and naval vehicles.

### Best in class Performance

The dual Intel Quad Core i7 platform is capable of more than 260 Gigaflops peak performance and 21GBytes per second main memory bandwidth with error checking and correction (ECC). DSP280 sets the standard for deployed DSP and multiprocessing applications such as radar, sonar, image and sensor processing and goes further with 3D Graphics to support general purpose and display processing.

### Scalability for best size, weight and power (SWaP)

The HPEC architecture can scale from one to many CPU nodes per enclosure via two dual port RDMA enabled network interface controllers (rNICs) delivering up to 3.7GBytes/s data rates at less than 1µs memory to memory latencies between nodes. In addition, system integrators can minimize card count by mapping multiple platform functions such as control, DSP and graphics

onto one or more DSP280s in order to reduce spares and simplify logistical support in the field.

### High Performance embedded Computing (HPEC)

DSP280 is a key member of GE's HPEC product family which includes our new SBC624 2nd Generation Core i7 6U OpenVPX SBC, our latest NPN240 dual NVIDIA CUDA GPGPUs and switch fabric modules (SFMs) such as the GBX460 10GE card. These COTS OpenVPX modules harness mainstream LINUX and Windows™ platforms along with open middlewares to deliver world class performance at a fraction of the cost of proprietary solutions.

### AXIS Advanced Multiprocessor Integrated Software

AXISLIB-AVX is GE's comprehensive DSP and math function library providing the full VSIPL Core 1.0 profile with hand optimized AVX support to extract game changing levels of performance from Intel's brand new 256bit wide SIMD AVX unit. The VSIPL API ensures code portability across multiple processor generations in support of planned technology refresh during the entire program life cycle.

AXISPRO includes a high performance IPC middleware and GUI for task level programming and fast prototyping to reduce development cost and shorten time to solution of even the most complex signal processing applications.



# Dual socket 2nd generation Intel Quad Core i7 Multiprocessor

## Specifications

### Processors & Main Memory

- 2 x Quad Core i7-2715QE BGA @ 2.1GHz base frequency with 3D Graphics & dynamic Turbo Boost Technology 6MB shared L3 cache 16GBBytes memory down per board
- 2 Channels 1333MHz ECC DDR3 SDRAM per CPU
- Build options: 8GB and 32GB (future)
- Non-volatile Memory per CPU:
  - 2 x 4Mbytes SPI BIOS FLASH with protected recovery BANC FLASH (1 device)
  - 512KBytes non-volatile memory (MRAM)
  - 8 Gigabytes NAND FLASH DISK

### OpenVPX VITA65 Profiles:

- SLOT: SLT6-PAY-4F1Q2U2T-10.2.1
- Module: MOD6-PAY-4F1Q2U2T-12.2.1-8

### I/O Planes:

- Utility: Power, I2C, Common clock
- Data: 4 Fat Pipes 10GE or DDR Infiniband with RDMA via 2 dual port Mellanox® ConnectX-2™ rNICs
- Expansion: 2 Double FPs or 4 Fat Pipes PCIe via IDT 32 lane gen 2 switch with 4 channel DMA
- Control: Two 1000Base-BX (1 per node)
- Network: Two 1000Base-T (1 per node)

### Circuit Card Assembly (CCA) Build Levels:

Monolithic construction for extended temperature, shock and vibration environments.

### Air cooled assemblies:

- Level 1, 2 and 3
- Air flow-through assemblies:
- VITA48.5 Build Option

### Conduction cooled assemblies:

- Level 4 & 5 at 0.85" pitch
- VITA 48.5 Build Option (consult Product Management)

### Software

- AMI UEFI BIOS
- Built In Test (POST)
- LINUX SDK
- Windows® SDK
- Open-GL

### RTOS Support:

Consult Product Management for specific RTOS availability.

### AXIS Advanced Multiprocessor Integrated Software

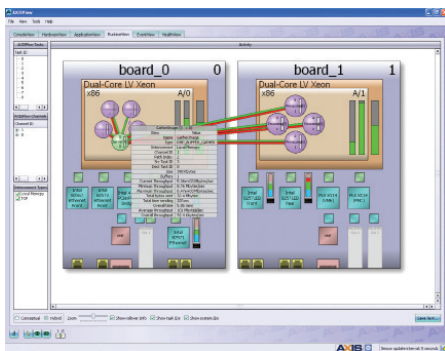

## Block Diagram

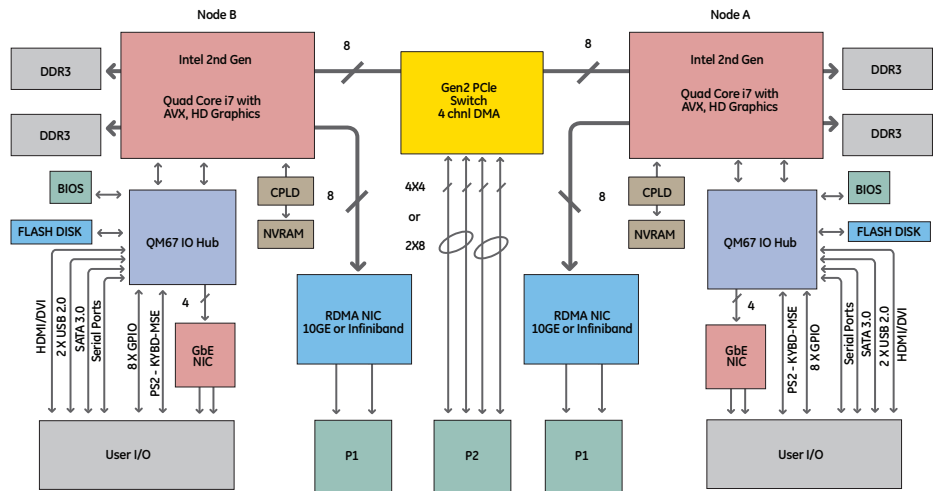

### AXISPRO:

Integrated GUI for task level programming and fast prototyping with AXISFlow Interprocessor Communication (IPC) middleware.

### OFED RDMA:

Open Fabrics Alliance OFED RDMA support on Windows & LINUX

### Open IPC Middleware:

Open-MPI and Sockets Direct support on Windows & LINUX

### AXISLIB-AVX:

VSIPL Core 1.0 profile API with over 600 DSP and Math functions using optimized AVX libraries for maximum performance and code portability. Includes RSPL API build for increased efficiency and control.

## Ordering Information

### DSP280-142A0103 = standard build

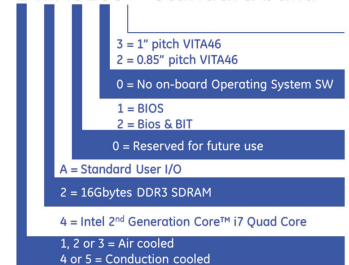

## About GE Intelligent Platforms

GE Intelligent Platforms, a General Electric Company (NYSE: GE), is an experienced high-performance technology company and a global provider of hardware, software, services, and expertise in automation and embedded computing. We offer a unique foundation of agile, advanced and ultra-reliable technology that provides customers a sustainable advantage in the industries they serve, including energy, water, consumer packaged goods, government and defense, and telecommunications. GE Intelligent Platforms is a worldwide company headquartered in Charlottesville, VA and is part of GE Home and Business Solutions. For more information, visit [www.ge-ip.com](http://www.ge-ip.com).

## GE Intelligent Platforms Contact Information

Americas: 1 800 433 2682 or 1 434 978 5100

Global regional phone numbers are listed by location on our web site at [www.ge-ip.com/contact](http://www.ge-ip.com/contact)

[defense.ge-ip.com](http://defense.ge-ip.com)

