

POINT I/O Selection Guide



Catalog Numbers Bulletin 1734
Selection Guide



Important User Information

Solid state equipment has operational characteristics differing from those of electromechanical equipment. Safety Guidelines for the Application, Installation and Maintenance of Solid State Controls (publication [SGI-1.1](http://literature.rockwellautomation.com) available from your local Rockwell Automation sales office or online at <http://literature.rockwellautomation.com>) describes some important differences between solid state equipment and hard-wired electromechanical devices. Because of this difference, and also because of the wide variety of uses for solid state equipment, all persons responsible for applying this equipment must satisfy themselves that each intended application of this equipment is acceptable.





In no event will Rockwell Automation, Inc. be responsible or liable for indirect or consequential damages resulting from the use or application of this equipment.

The examples and diagrams in this manual are included solely for illustrative purposes. Because of the many variables and requirements associated with any particular installation, Rockwell Automation, Inc. cannot assume responsibility or liability for actual use based on the examples and diagrams.

No patent liability is assumed by Rockwell Automation, Inc. with respect to use of information, circuits, equipment, or software described in this manual.

Reproduction of the contents of this manual, in whole or in part, without written permission of Rockwell Automation, Inc., is prohibited.

Throughout this manual, when necessary, we use notes to make you aware of safety considerations.

WARNING 	Identifies information about practices or circumstances that can cause an explosion in a hazardous environment, which may lead to personal injury or death, property damage, or economic loss.
IMPORTANT	Identifies information that is critical for successful application and understanding of the product.
ATTENTION 	Identifies information about practices or circumstances that can lead to: personal injury or death, property damage, or economic loss. Attentions help you identify a hazard, avoid a hazard, and recognize the consequence.
SHOCK HAZARD 	Labels may be on or inside the equipment, such as a drive or motor, to alert people that dangerous voltage may be present.
BURN HAZARD 	Labels may be on or inside the equipment, such as a drive or motor, to alert people that surfaces may reach dangerous temperatures.

Allen-Bradley, Rockwell Automation, POINT I/O, POINT Guard I/O, POINTBus, GuardLogix, RSLogix 5000, DeviceLogix, and TechConnect are trademarks of Rockwell Automation, Inc.

Trademarks not belonging to Rockwell Automation are property of their respective companies.

	Chapter 1	
POINT I/O Family	Overview	5
	The POINT I/O System	6
	POINT I/O Features	7
	Specify a POINT I/O System	8
	Chapter 2	
Select POINT I/O Communication Interfaces	Overview	9
	NetLinx Open Network Architecture	9
	Select a Network	10
	EtherNet I/P Network	11
	ControlNet Network	12
	Memory Requirements	14
	DeviceNet Network	15
	About the 1734D Series	17
	PROFIBUS DP Network	18
	Communication Adapter Environmental Specifications	19
	Chapter 3	
Select POINT I/O Modules	Select POINT I/O Modules	21
	Digital I/O Modules	22
	Digital AC Input Modules	23
	Digital AC Output Modules	23
	Digital DC Input Modules	24
	Digital DC Output Modules	24
	Digital Contact Modules	25
	Digital POINTBlock AC/DC DeviceNet Adapters	26
	Digital I/O Modules Environmental Specifications	26
	Self Configurable Modules	27
	Self Configurable Modules Environmental Specifications	27
	Analog and Temperature I/O Modules	28
	Analog Input Modules	29
	Temperature Input Modules	30
	Analog Output Modules	33
	Analog and Temperature I/O Modules Environmental Specifications	34
	Specialty I/O Modules	34
	1734-232ASC and 1734-485ASC Serial Interface Modules	34
	1734-SSI Synchronous Serial Interface Module with Absolute Encoder	35
	1734-ARM Address Reserve Module	37
	1734-CTM Common Terminal and 1734-VTM Voltage Terminal Modules	37
	Specialty I/O Modules Environmental Specifications	38
	Counter Modules	39
	Counter Modules Environmental Specifications	42
	Safety I/O Modules	42
	POINT I/O Accessories	45

	Chapter 4	
Select a Terminal Base Assembly	Terminal Base Assembly	47
	One-piece Terminal Bases	49
	Chapter 5	
Select a Power Supply Unit	POINT I/O Communication Adapters	51
	Expansion Power Supplies	52
	Field Power Distributor	56
	Chapter 6	
Mounting Requirements	Power Supply Distance Rating	59
	Mount the POINT I/O System	60
	Approximate Mounting Dimensions	61
	Chapter 7	
Related Documentation		

POINT I/O Family

Overview



The POINT I/O family has modular I/O modules that are ideal for applications where flexibility and low-cost of ownership are key for successful control system design and operation. As a key element in the Rockwell Automation Integrated Architecture, its comprehensive diagnostics and configurable features allow the product to be easily applied to any automation system and reduce engineering costs through standardization. It can be used in remote device panels, local control panels, and can be accessed from many locations including the Internet. This product has just-what-you-need granularity in 1 to 8 points to reduce system cost and size.

Available features include Channel Level Diagnostics for quick troubleshooting, multiple termination options and flexibility to save money, cabinet space and commissioning/troubleshooting time, the ability to mix/match Safety I/O on the same bus, and available DeviceLogix for local control, fast response time. Self-Configuring modules are also available to reduce/simplify your design and your inventory.

The POINT I/O System

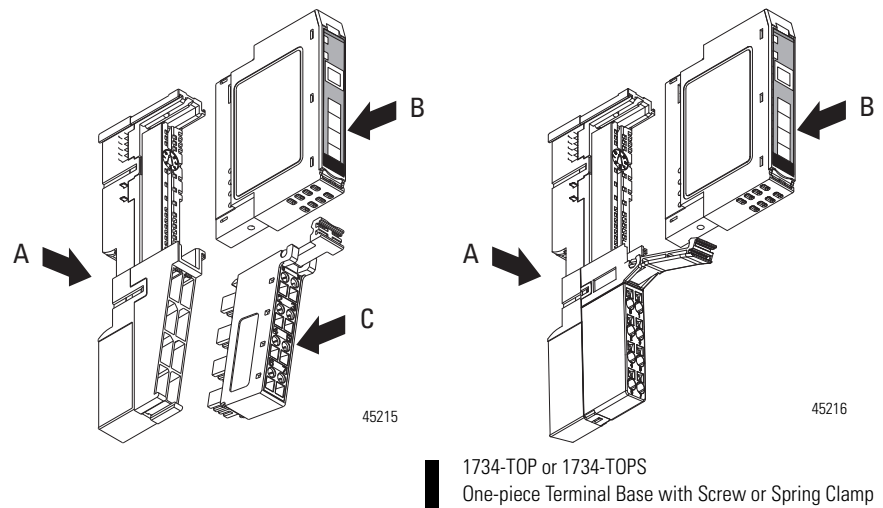

The base (A) mounts onto the DIN rail and provides the backplane. The POINT I/O module (B) snaps into the base. The removable terminal block (C) also snaps into the base and provides the wiring and terminations for field-side connections, as well as system power for the backplane.

POINT I/O has 4 major components:

- I/O modules provide the field interface and system-interface circuitry
- Communication interface modules provide the network-interface circuitry
- Terminal base units provide the wiring and signal termination for field-side connections and system power for the backplane
- Power distribution modules provide the expandability of the POINT I/O system and the flexibility to mix a variety of signal types

1734 POINT I/O modules offer 1 to 8 points per module. The I/O modules are interfaced to a network through a communication interface, which includes a built-in power supply that converts incoming 24V DC power to 5V DC backplane power. Each type of communication interface (Network Adaptor) supports a maximum of 13 to 17 I/O modules, with a maximum of 10 A field power. The I/O modules receive power from the power supply through the backplane. With an external power supply, you can expand a POINT I/O assembly up to a maximum of 63 I/O modules or 504 channels.

1734D Series POINTBlock I/O provides a DeviceNet communication interface with up to 16 integrated I/O points in a single module. You can add up to 13 POINT I/O modules to a POINTBlock I/O assembly, for a maximum of 120 channels per assembly.

POINT I/O Features

Adapters	<ul style="list-style-type: none"> • ControlNet • DeviceNet • EtherNet I/P • Profibus
I/O Types	<ul style="list-style-type: none"> • Digital • Analog • AC/DC • Thermocouple • RTD • Specialty
Module Density	1...8 points
Specialty Modules	<ul style="list-style-type: none"> • Encoder • 1 MHz Counter In • Counter In with Outputs • Serial RS232 • RS485 • RS422 • Channel Isolated Thermocouple • RTD • Serial Synchronous Interface (SSI) • Address Reserve
Module Features	<ul style="list-style-type: none"> • Channel-level diagnostics (LED indicator and electronic) • Channel-level alarm and annunciation (electronic) • Channel-level open-wire detection with electronic feedback • Channel-level short-circuit detection with electronic feedback • Parameter-level explicit messaging • Removal and insertion under power (RIUP) • Horizontal or vertical mounting without derating • Automatic Device Replacement • Add-On-Profiles in RSLogix 5000
Network Connectivity	<ul style="list-style-type: none"> • DeviceNet (including SubNet connectivity) • ControlNet (Logix controller only) • EtherNet/IP (Logix controller only) • PROFIBUS DP • OPC/DDE Data Monitoring"
Environmental Style	Class I, Division 2/Zone 2, Marine Certification, European ATEX Zone 2 3G
Modules per Node, max	Up to 63

Specify a POINT I/O System

Follow these steps as you specify your POINT I/O system:

	Step	Remember to select
✓	<p>1 Select a communication interface</p> <p>Choose the interface module for your operating system.</p>	<ul style="list-style-type: none"> the appropriate interface module a communication interface that meets the power requirements of your system
✓	<p>2 Select I/O devices based on field devices</p> <ul style="list-style-type: none"> location of the device number of points needed appropriate catalog number number of points available per module number of modules 	<ul style="list-style-type: none"> I/O modules - some have diagnostic features, electronic fusing, isolated inputs/outputs, and unique configurable features
✓	<p>3 Select a wiring base assembly</p> <p>Choose the appropriate wiring base assembly</p>	<ul style="list-style-type: none"> the appropriate wiring base assembly: <ul style="list-style-type: none"> Single piece screw, single piece spring, or RTB (Removable Terminal Base)
✓	<p>4 Select optional power components</p> <p>Choose optional components to extend backplane power or change the field power distribution source.</p>	<ul style="list-style-type: none"> additional power components as necessary adequate power capacity to meet I/O module backplane current requirements
✓	<p>5 Determine mounting requirements</p> <p>Determine needed dimensions based on the communication interface chosen.</p>	<ul style="list-style-type: none"> the appropriate number of DIN rails based on the number of modules and the physical locations of those modules horizontal or vertical mounting with no thermal derating

Select POINT I/O Communication Interfaces

Step 1 - Select:

- a communication interface module

NetLinx Open Network Architecture.....	page 9
EtherNet I/P Network.....	page 11
ControlNet Network.....	page 12
DeviceNet Network.....	page 15
PROFIBUS DP Network.....	page 18

Overview

Separate communication interface adapters are available for different networks. Install adapters into the POINTBus backplane to allow POINT I/O modules to communicate with a controller.

NetLinx Open Network Architecture

NetLinx Open Network Architecture is the Rockwell Automation strategy of using open networking technology for seamless, top-floor to shop-floor integration. The NetLinx-based networks – DeviceNet, ControlNet, and EtherNet/IP – all use the Common Industrial Protocol (CIP), so they speak a common language and share a universal set of communication services. NetLinx architecture, part of the Integrated Architecture platform, seamlessly integrates all the components in an automation system from a few devices on one network to multiple devices on multiple networks including access to the Internet – helping you to improve flexibility, reduce installation costs, and increase productivity.

- The EtherNet/IP network is an open industrial-networking standard that supports implicit and explicit messaging and uses commercial, off-the-shelf Ethernet equipment and physical media.
- The ControlNet network allows intelligent, high-speed control devices to share the information required for supervisory control, work-cell coordination, operator interface, remote device configuration, programming, and troubleshooting.

- The DeviceNet network offers low-cost, high-speed access to plant-floor data from a broad range of plant-floor devices and a significant reduction in wiring.



Select a Network

You can configure your system for information exchange between a range of devices and computing platforms and operating systems.

Application requirements	Network	Select
<ul style="list-style-type: none"> • Plant management (material handling) • Configuration, data collection, and control on a single, high-speed network • Time-critical applications with no established schedule • Data sent regularly • Internet/Intranet connection • Close IT & Manufacturing Integration • Built-in switch, or high availability requirement (2-port AENTR) 	EtherNet/IP	1734-AENT 1734-AENTR
<ul style="list-style-type: none"> • High-speed transfer of time-critical data between controllers and I/O devices • Deterministic and repeatable data delivery • Media redundancy • Controller redundancy • Intrinsic safety 	ControlNet	1734-ACNR
<ul style="list-style-type: none"> • Connections of low-level devices directly to plant-floor controllers, without interfacing them • Data sent as needed • More diagnostics for improved data collection and fault detection • Less wiring and reduced start-up time than a traditional, hard-wired system • High noise resistance, and power over network 	DeviceNet	1734-ADN 1734-ADN(X) 1734-PDN 1734D-series
<ul style="list-style-type: none"> • Connecting to an existing PROFIBUS DP 5 m (16.4 ft) bus, 12 MB network 	PROFIBUS	1734-APB

EtherNet I/P Network

The Ethernet Industrial (EtherNet/IP) network protocol is an open industrial-networking standard that supports both real-time I/O messaging and message exchange. It emerged due to the high demand for using the Ethernet network for control applications. The EtherNet/IP network uses off-the-shelf Ethernet communication chips and physical media. The EtherNet/IP network provides excellent drive and I/O control performance along with HMI information processing and many commercial technologies.

EtherNet/IP Network Considerations

Adapter	Considerations
1734-AENT 1734-AENTR	<p>A total of 63 POINT I/O modules can be assembled on a single EtherNet/IP node.</p> <p>Expansion power supplies may be used to provide additional POINTBus backplane current.</p> <p>Refer to the User Manual to determine the ratings for direct and rack connections allowed.</p>

The 1734-AENT/1734-AENTR adapter supports direct- and rack-optimized connections. A direct connection is a real-time data transfer link between the controller and whatever module occupies the slot that the configuration data references. Direct-connection messaging occurs at a cyclic rate specified by the requested packet interval (RPI) during configuration. A rack-optimized connection is a grouping of data from more than one I/O module into a single block of data sent over a single connection at the same data rate. Rack-optimized connections reduce the total number of connections needed to transfer data when using many I/O modules in a system.

Assume a system contains 8 digital I/O modules interfaced to a 1734-AENT/1734-AENTR adapter. If you used direct connections to transfer data to each of these modules, you need 8 connections — one to each of the 8 I/O modules. If you use a rack-optimized connection to transfer the

data, you need only a single connection — the connection to the 1734-AENT/1734-AENTR adapter.

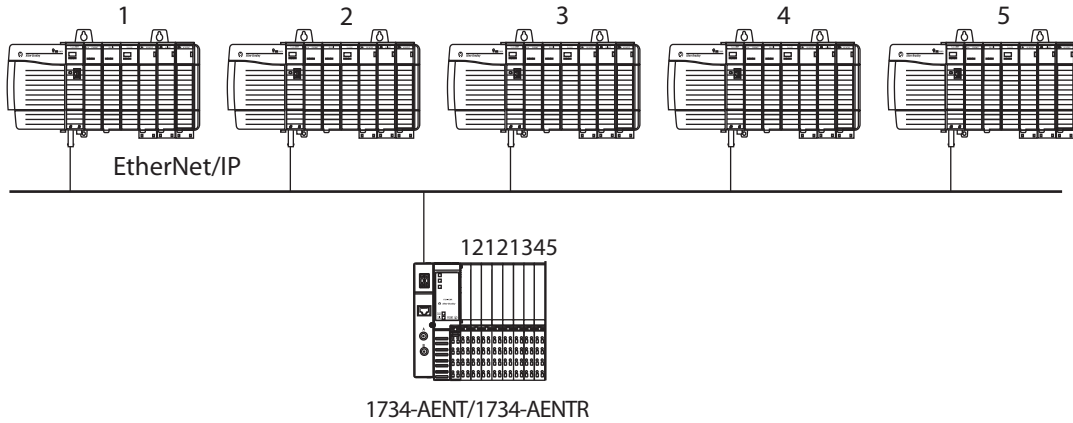

45102

1734-AENT/1734-AENTR Technical Specifications

	1734-AENT/1734-AENTR
Input Voltage, Nom.	24V DC
Input Voltage Range	10...28.8V DC
Field Side Power Requirements	400 mA @ 24V DC (+20% = 28.8V DC)
Inrush Current	6 A for 10 ms
POINTBus current (mA)	800 (1734-AENTR) 1000 (1734-AENT)
Power Consumption at 24V	4.5 W
Power dissipation, max.	2.8 W @ 28.8V
Input Overvoltage Protection	Reverse polarity protected
Interruption	Output voltage will stay within specifications when input drops out for 10 ms at 10V with max load.

ControlNet Network

The ControlNet network is an open, state-of-the-art control network that meets the demands of real-time, high-throughput applications. The ControlNet network uses the proven Common Industrial Protocol (CIP) to combine the functionality of an I/O network and a peer-to-peer network providing high-speed performance for both functions. The ControlNet network gives you deterministic, repeatable

transfers of all mission-critical control data in addition to supporting transfers of non-time-critical data.

ControlNet Network Considerations

Adapter	Considerations
1734-ACNR	<p>A total of 63 POINT I/O modules can be assembled on a single ControlNet node.</p> <p>Expansion power supplies may be used to provide additional POINTBus backplane current.</p> <p>Up to 25 direct connections and 5 rack connections are allowed.</p>

The 1734-ACNR ControlNet adapter provides high-speed transfer of time critical data between controllers and I/O devices. It manages data transfers between controllers on the ControlNet network and POINT I/O modules plugged into the POINTBus backplane. The ControlNet network allows the exchange of messages between ControlNet products compliant with the ControlNet International specification. The 1734-ACNR adapter features include a variety of control system solutions, local communication network access through the network access port (NAP), and redundant media. It requires Series C POINT I/O modules or later.

The 1734-ACNR adapter requires a typical 24V DC power supply with a maximum of 10.2 W of power. It provides a maximum backplane current of 1.0 A at 5V DC. Backplane current can be extended beyond 1.0 A with a 1734-EP24DC backplane extension power supply. The 1734-EP24DC can supply up to an additional 1.3 A of backplane current. Multiple 1734-EP24DC power supplies can be used to reach the maximum limit of 63 POINT I/O modules if 25 or fewer of these modules are analog or specialty modules.

The adapter supports 25 direct and 5 rack I/O connections to the POINT I/O modules. From a single 1734-ACNR adapter, multiple controllers establish I/O connections, up to a maximum of 5 rack I/O connections per adapter. Direct connections must be used with analog and specialty modules. Multiple rack connections permit multiple controllers to connect to I/O over a single 1734-ACNR adapter. The number of connections that can be supported on a network depends on the ControlNet parameters (NUT, RPI, and API) and the POINT I/O configuration by itself (number and types of I/O modules).

The following example shows a single POINT I/O ControlNet adapter with 5 connections and 8 I/O modules. The POINT I/O modules are monitored by the 5 controllers on the ControlNet network. The POINT I/O modules in:

- slots 1, 3, and 5 are controlled by the first controller.
- slots 2 and 4 by the second controller.
- slot 6 by the third controller.
- slot 7 by the fourth controller.

- slot 8 by the fifth controller.

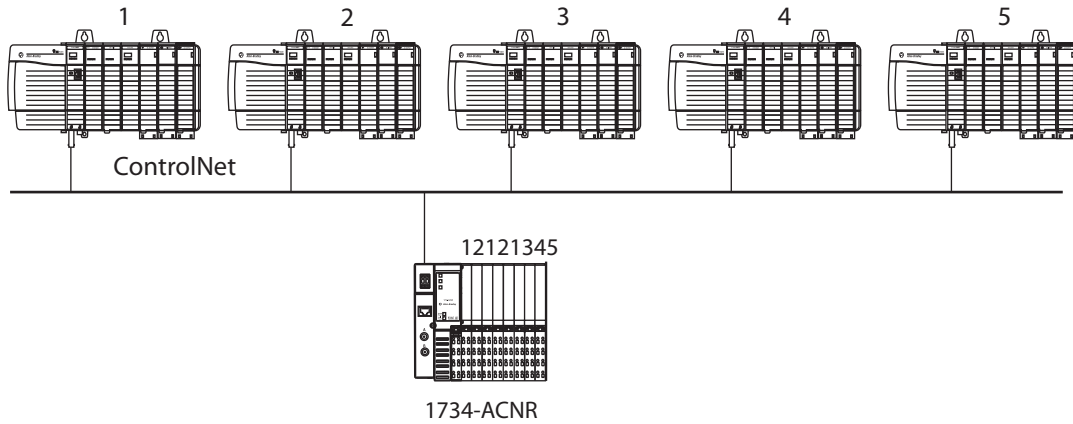

Memory Requirements

The 1734-ACNR adapter has 586 bytes of memory available for scheduled transmit data. When developing an application, the amount of data used by an individual connection must also include a small amount of overhead (I/O bytes per connection).

The following formula tracks the amount of available scheduled transmit data.

$$\text{Available Memory} = 586 - [(\text{Number of connections} * 10) + \text{Sum of all connection sizes}]$$

In the following example, the system uses a 1734-ACNR adapter with five 1734-232ASC modules.

	Application Data Size (number of bytes)	Memory Required
1734-232ASC - 1	100	110
1734-232ASC - 2	88	98
1734-232ASC - 3	96	106
1734-232ASC - 4	96	106
1734-232ASC - 5	92	102
Total Bytes Used	472	522

In this example, a sixth module could be added if it used less than 54 bytes of application data. There are 64 bytes of memory left. $64 = 586 - [(5 * 10) + 472]$

For more information about the 1734-ACNR adapter, see the POINT I/O ControlNet Adapter User Manual, publication [1734-UM008](#).

1734-ACNR Technical Specifications

	1734-ACNR
Input voltage, nom	24V DC
Input voltage range	10...28.8V DC
Field side power requirements	425 mA @ 24V DC (+20% = 28.8V DC)
Inrush current	6 A for 10 ms
POINTBus current	1000 mA ⁽¹⁾
Power consumption at 24V	8.0 W
Power dissipation, max.	2.8 W @ 28.8V
Input overvoltage protection	Reverse polarity protected
Interruption	Output voltage will stay within specifications when input drops out for 10 ms at 10V with max load.

⁽¹⁾ 1000 mA @ 5V DC \pm 5% (4.75...5.25V).

DeviceNet Network

The DeviceNet network is an open low-level network that provides connections between simple industrial devices (such as sensors and actuators) and higher-level devices (such as PLC controllers and computers). The DeviceNet network uses the proven Common Industrial Protocol (CIP) to provide the control, configure, and data collection capabilities for industrial devices. The POINT I/O family offers four interfaces for connecting to the DeviceNet network.

DeviceNet Network Considerations

Adapter	Consideration
1734-ADN	<ul style="list-style-type: none"> All POINT I/O modules count as a single node on the main network. A total of 63 POINT I/O modules can be assembled on a single DeviceNet node. Behaves as a slave device on the main network and a master on the POINTBus backplane. RSNetWorx for DeviceNet software is needed for configuration of the 1734-ADN adapter on the main network and the POINTBus backplane Expansion power supplies may be used to provide additional POINTBus backplane current.

DeviceNet Network Considerations

Adapter	Consideration
1734-ADNX	<ul style="list-style-type: none"> • Acts like a 1734-ADN adapter, with additional capabilities. • All POINT I/O modules, and some third-party field devices, count as a single node on the main network. • Has a second, Phoenix-style connector that extends the subnet off the module, so that any DeviceNet-capable device could be connected to a subnet and scanned by the 1734-ADNX adapter. • Network on the second connector is electrically isolated from the main network and can be used to extend the total DeviceNet trunk line distance.⁽¹⁾ • Node numbers of the devices on the POINTBus backplane and subnet would not count against the 63 slave nodes allowed on the main network. • Devices on the subnet and the main network need to be connected at different communication rates or use different sampling methods (for example, change-of-state or polled). • Data from these devices would be included in the data being sent to/from the 1734-ADNX adapter on the main network. • POINT I/O expansion power supplies are permitted and may be required to add more modules.
1734D POINTBlock Series	<ul style="list-style-type: none"> • Each POINT I/O module on the main network counts as a separate node. • Appears to the main network as a 1734-PDN communication interface with a single, 16-point module attached. • Any of the I/O modules may be attached in the same manner they are added to a 1734-PDN communication interface. • Total POINTBus backplane current of I/O modules cannot exceed 1.0 A. • Expansion power supplies may not be used.
1734-PDN	<ul style="list-style-type: none"> • Each POINT I/O module on the main network counts as a separate node. • Electrically connects the main network to the I/O modules, which are connected on the POINTBus backplane. • No configuration to the 1734-PDN communication interface necessary since it is transparent to the main network. • Total POINTBus backplane current of I/O modules cannot exceed 1.3 A. • Expansion power supplies may not be used.

⁽¹⁾ For example: with thick round media at 125 Kbps, you could run a maximum of 500 m (1640 ft) to a 1734-ADNX adapter on the main network. You could then wire an additional 500 m (1640 ft) of cable on the subnet connector and double the distance of the network. **Remember that this subnet needs terminating resistors and a 24V DC power connection, the same as any other DeviceNet network.**

It is important that the total amount of data coming from the subnet does not exceed the data capability of either the 1734-ADN or 1734-ADNX adapter.

- 250 bytes (248 data + 2 bytes command info) for output data (used as either COS, cyclic, or poll)
- 250 bytes (248 data + 2 bytes status info) for polled input data
- 250 bytes (248 data + 2 bytes status info) for COS/cyclic input data
- 8 bytes (6 data + 2 status info) for strobe input data

The data coming through the 1734 adapter combined with the other data from the main network cannot exceed the data capability of the

main network master scanner. If this occurs, you will need multiple master scanners on the main network and the I/O modules on the subnet will need to be split between multiple 1734-ADN or 1734-ADNX adapters.

With the 1734-PDN communication interface, the multiple masters on the main network will be able to communicate to separate groups of modules on its subnet through the same 1734-PDN communication interface, so no additional adapter would be necessary.

About the 1734D Series

The 1734D POINTBlock series is a set of DIN-rail mounted products with an integrated DeviceNet communication interface, various combinations of onboard I/O points, removable terminations, and a POINTBus expansion port.

The DeviceNet interface presents the integrated I/O as a single DeviceNet node while expansion I/O modules will appear as separate nodes.

The 1734D series includes a nonisolated DeviceNet communication interface. The 24V DC from the DeviceNet connection powers a nonisolated DC/DC converter that generates +5V DC. This +5V DC powers the 1734D series electronics and connects to the POINTBus port to power the expansion I/O electronics.

See the Select POINT I/O Modules section of this document for POINTBlock I/O module catalog numbers and specifications.

1734 DeviceNet Adapters Technical Specifications

	1734-PDN 1734D	Series	1734-ADN/X
Input voltage, nom	24V DC	10...28.8V DC	24V DC
Input voltage range	11...25V DC DeviceNet specification	11...25V DC DeviceNet specification	10...28.8V DC
Field side power requirements	400 mA @ 24V DC (+4% = 25V DC)	350 mA @ 24V DC (+4% = 25V DC)	400 mA @ 24V DC (+20% = 28.8V DC)
Inrush current	6 A for 5 ms	6 A for 5 ms	6 A for 10 ms
POINTBus current	1300 ⁽¹⁾ mA	1000 ⁽²⁾ mA	1000 mA
Power consumption at 24V	8.0 W	8.2 W	8.1 W

1734 DeviceNet Adapters Technical Specifications

	1734-PDN 1734D	Series	1734-ADN/X
Power dissipation, max.	1.2 W @ 25V	2.0 W @ 24V	2.8 W @ 28.8V
Input overvoltage protection	Reverse polarity protected		
Interruption	—	—	Output voltage will stay within specifications when input drops out for 10 ms at 10V with max load.

⁽¹⁾ 1300 mA @ 5V DC $\pm 5\%$ (4.75...5.25V).

⁽²⁾ 1000 mA @ 5V DC $\pm 5\%$ (4.75...5.25V).

PROFIBUS DP Network

PROFIBUS for Decentralized Peripherals is a standard in field bus communication in automation. that helps eliminate hard wiring, and reduces costs associated with design and installation.

PROFIBUS DP Network Considerations

Adapter	Considerations
1734-APB	A total of 63 POINT I/O modules can be assembled on a single PROFIBUS DP node. Expansion power supplies may be used to provide additional POINTBus backplane current.

Other considerations when using the APB adapter. Example, if needed (see EtherNet/IP section).

1734-APB Technical Specifications

Attribute	Value
Input voltage, nom	24V DC
Input voltage range	10...28.8V DC
Field side power requirements	400 mA @ 24V DC (+20% = 28.8V DC)
Inrush current	6 A for 10 ms
POINTBus current	1000 mA ⁽¹⁾
Power consumption at 24V	8.0 W
Power dissipation, max.	2.8 W @ 28.8V
Input overvoltage protection	Reverse polarity protected
Interruption	Output voltage will stay within specifications when input drops out for 10 ms at 10V with max load.

⁽¹⁾ 1000 mA @ 5V DC $\pm 5\%$ (4.75...5.25V).

Communication Adapter Environmental Specifications

Attribute	Value
Operating temperature	-20...55° C (-4...131° F)
Nonoperating temperature	-40...85° C (-40...185° F)
Relative humidity	5...95% noncondensing
Operating shock	30 g
Nonoperating shock	50 g
Vibration	5 g @ 10...500Hz
Enclosure type rating	None (open-style)
Mounting	DIN Rail
Certifications (when product is marked)	c-UL-us, Ex, CE , C-Tick , CI / EtherNet/IP / DeviceNet

Notes:

Select POINT I/O Modules

Step 2 - Select:

- I/O modules - some modules have diagnostic features, electronic fusing, or individually isolated inputs/outputs

Digital I/O Modules.....	page 22
Analog and Temperature I/O Modules.....	page 28
Specialty I/O Modules	page 34
Counter Modules.....	page 39
Safety I/O Modules	page 42
POINT I/O Accessories	page 45

Select POINT I/O Modules

The POINT I/O family provides a wide range of input and output modules to span many applications, from high-speed digital to process control. POINT I/O modules support producer/consumer technology, which allows input information and output status to be shared among multiple Logix controllers.



Each POINT I/O module mounts adjacent to the network adapter or another I/O module and removable terminal block (RTB) to connect all field-side wiring. The RTBs are part of the terminal base assembly. They are not included with the I/O modules and must be ordered separately.

The POINT family of I/O modules includes:

- 1734 digital I/O modules.
- 1734 analog I/O modules.
- 1734 specialty I/O modules.
- 1734 wiring systems.
- 1734 network communication adapters.
- 1734 POINT Guard I/O modules.

Digital I/O Modules

Choose digital I/O modules when you need:

- a wide variety of voltage interface capabilities
- isolated and non-isolated module types
- point-level output fault states
- choice of direct-connect or rack-optimized communications
- field-side diagnostics (on select modules)

Most output modules have built-in surge suppression to reduce the effects of high-voltage transients. However, we recommend that you use an additional suppression device if an output is being used to control inductive devices, such as:

- relays
- motor starters
- solenoids
- motors

Additional suppression is especially important if your inductive device is in series with or parallel to hard contacts, such as push buttons or selector switches.

Digital AC Input Modules

1734 Digital AC Input Modules Technical Specifications

	1734-IA2	1734-IA4	1734-IM2	1734-IM4
Number of inputs	2 (1 group of 2)	2 (1 group of 4)	2 (1 group of 2)	2 (1 group of 4)
Voltage, on-state input, nom	120V AC		220V AC	
Voltage, on-state input, min	65V AC		159V AC	
Voltage, on-state input, max	132V AC		264V AC	
Input delay time, on to off	20 ms hardware filter plus 0...65 ms digital filter programmable in increments of 1 ms ⁽¹⁾			
Current, on-state input, min	4.0 mA @ 65V AC, 60 Hz		6.2 mA @ 159V AC, 60 Hz	
Input impedance, nom	10.6 k Ω		22.3 k Ω	
Current, off-state input, max	2.7 mA @ 43V AC		2.9 mA	
POINTBus current	75 mA @ 5V DC			
Power dissipation, max	0.1 W @ 132V AC			
Thermal dissipation, max	3.4 BTU @ 132V AC			
Terminal base unit	1734-TB, 1734-TBS, 1734-TOP, or 1734-TOPS			

⁽¹⁾ Input ON-to-OFF delay time is the time from a valid input signal to recognition by the module.

Digital AC Output Modules

1734 Digital AC Output Modules Technical Specifications

	1734-OA2	1734-OA4
Number of outputs	2	4
Voltage, on-state output, nom	120V AC; 220V AC	
Voltage, on-state output, min	74V AC	
Voltage, on-state output, max	264V AC	
Output current rating	1.5 A (2 channels @ 0.75 A each)	2.0 A (750 mA per output, 2.0 A max per module)
POINTBus current	75 mA @ 5V DC	
Power dissipation, max	2 W @ 264V AC	3.5 W @ 264V AC
Thermal dissipation, max	6.8 BTU @ 264V AC	11.69 BTU @ 264V AC
Terminal base unit	1734-TB, 1734-TBS, 1734-TOP, or 1734-TOPS	

Digital DC Input Modules

1734 Digital DC Input Modules Technical Specifications

	1734-IB2	1734-IB4	1734-IB4D	1734-IB8	1734-IV2	1734-IV4	1734-IV8
	Sinking Input Modules				Sourcing Input Modules		
Number of inputs	2	4	4	8	2	4	8
Diagnostics	—	—	Yes	—	—	—	—
Voltage, on-state input, nom	24V DC						
Voltage, on-state input, min	10V DC						
Voltage, on-state input, max	28.8V DC						
Input delay time, on to off	0.5 ms hardware + (0...65 ms selectable) ⁽¹⁾						
Current, on-state input, min	2 mA						
Current, on-state input, max	5 mA						
Current, off-state input, max	1.5 mA						
POINTBus current (mA)	75 mA max @ 5V DC		50 mA max @ 5V DC	75 mA max @ 5V DC			
Power dissipation, max	0.7 W @ 28.8V DC	1.0 W @ 28.8V DC	0.6 W max @ 28.8V DC	1.6 W @ 28.8V DC	0.7 W @ 28.8V DC	1.0 W @ 28.8V DC	1.6 W @ 28.8V DC
Thermal dissipation, max	2.4 BTU/hr @ 28.8V DC	3.4 BTU/hr @ 28.8V DC	1.9 BTU/hr @ 28.8V DC	5.5 BTU/hr @ 28.8V DC	2.4 BTU/hr @ 28.8V DC	3.4 BTU/hr @ 28.8V DC	5.5 BTU/hr @ 28.8V DC
Terminal base unit	1734-TB, 1734-TBS, 1734-TOP, or 1734-TOPS						

⁽¹⁾ Input ON-to-OFF delay time is the time from a valid input signal to recognition by the module.

Digital DC Output Modules

1734 Digital DC Output Modules Technical Specifications

	1734-OB2 ⁽¹⁾	1734-OB2E	1734-OB2EP	1734-OB4 ⁽¹⁾	1734-OB4E	1734-OB8 ⁽¹⁾	1734-OB8E	1734-OV2E	1734-OV4E	1734-OV8E
	Sourcing Output Modules						Sinking Output Modules			
Number of outputs	2		4	4	8		2	4	8	
Diagnostics	—	Yes	Yes	—	Yes	—	Yes	Yes	Yes	Yes
Electronically protected	Yes									
Voltage, on-state output, nom	24V DC									
Voltage, on-state output, min	10V DC									

1734 Digital DC Output Modules Technical Specifications

	1734-OB2⁽¹⁾	1734-OB2E	1734-OB2EP	1734-OB4⁽¹⁾	1734-OB4E	1734-OB8⁽¹⁾	1734-OB8E	1734-OV2E	1734-OV4E	1734-OV8E
Voltage, on-state output, max	28.8V DC									
Output current rating, max	2.0 A per module, 1.0 A per channel	4.0 A per module, 2.0 A per channel	3.0 A per module, 1.0 A per channel				2.0 A max per module, 1.0 A per output	3.0 A per module, 1.0 A per output	3.0 A per module, 1.0 A per channel	
POINTBus current (mA)	75									
Power dissipation, max	0.8 W @ 28.8V DC	3.4 W @ 28.8V DC	1.2 W @ 28.8V DC		2.0 W @ 28.8V DC		0.8 W max @ 28.8V DC	1.2 W max @ 28.8V DC	2.0 W max @ 28.8V DC	
Thermal dissipation, max	2.7 BTU/hr @ 28.8V DC	11.6 BTU/hr @ 28.8V DC	4.1 BTU/hr @ 28.8V DC		6.8 BTU/hr @ 28.8V DC		2.7 BTU/hr @ 28.8V DC	4.1 BTU/hr @ 28.8V DC	6.8 BTU/hr @ 28.8V DC	
Terminal base unit	1734-TB, 1734-TBS, 1734-TOP, or 1734-TOPS									

⁽¹⁾ Non-diagnostic, standard output modules.

Digital Contact Modules**1734 Digital Contact Modules Technical Specifications**

	1734-OW2	1734-OW4	1734-OX2
Number of outputs	2 N.O. relays	4 N.O. relays	2 Form C (N.O./N.C.) relays, isolated
Output delay time, on to off, max	26 ms ⁽¹⁾		10 ms ⁽¹⁾
Contact resistance, initial	30 mΩ		
Leakage current, off-state output, max	1.2 mA and bleed resistor through snubber circuit @ 240V AC		1.2 mA and bleed resistor through snubber circuit @ 240V AC
POINTBus current (mA)	80		100
Power dissipation, max	0.5 W		
Thermal dissipation, max	1.7 BTU/hr		
Terminal base unit	1734-TB, 1734-TBS, 1734-TOP, or 1734-TOPS		

⁽¹⁾ Time from valid output off signal to relay deenergization by module.

Digital POINTBlock AC/DC DeviceNet Adapters

1734 Digital POINTBlock AC/DC DeviceNet Adapters

	1734D-IA16 1734D-IA16S	1734D-IA8X0A8 1734D-IA8X0A8S	1734D-IA8X0W8 1734D-IA8X0W8S	1734D-IB16 1734D-IB16S	1734D-IB8X0B8E 1734D-IB8X0B8ES	1734D-IB8X0W8 1734D-IB8X0W8S
Number of inputs	16	8	8	16	8	8
Number of outputs	—	8	8	—	8	8
Voltage, on-state input, nom	120V AC			24V DC		
Input delay time, on to off	20.0 ms hardware + (0...65 ms selectable)			0.5 ms hardware + (0...65 ms selectable)		
Current, on-state input, min	5.0 mA			2.5 mA		
Current, on-state output, min	—	10 mA per output	10 mA per output	—	—	10 mA per output
POINTBus current (mA)	1000					
Power dissipation, max	2.0 W @ 24V DC					
Thermal dissipation, max	9.5 BTU/hr max @ 28.8V DC					

Digital I/O Modules Environmental Specifications

1734 Digital I/O Modules Environmental Specifications

Attribute	Value
Operating temperature	-20...55 °C (-4...131 °F)
Nonoperating temperature	-40...85 °C (-40...185 °F)
Relative humidity	5...95% noncondensing
Operating shock	30 g
Nonoperating shock	50 g
Vibration	5 g at 10...500 Hz
Enclosure type rating	None (open-style)
Mounting type	DIN-rail
Certifications (when product is marked)	CE, C-Tick, c-UL-us

Self Configurable Modules

1734 DC Configurable Input/Output Modules Technical Specifications

	1734-8CFG	1734-8CFGDLX (with DeviceLogix)
Number of inputs/iutputs	8	8
Voltage, on-state input, nom		
Voltage, on-state input, min	11V AC	
Voltage, on-state input, max		
Current, on-state input, min	2.0 mA	
Current, on-state input, max	5.0 mA	
Input filter	Each input independently settable in 1 ms intervals (truncated to 1 ms resolution). Default value is 1000 ms.	
Voltage, on-state output, nom	24V DC	
Voltage, on-state output, min	10V DC	
Voltage, on-state output, max	28.8V DC	
POINTBus current	100 mA @ 5V DC	
Power dissipation, max	2.6 W @ 28.8V DC	
Thermal dissipation, max	8.9 BTU/hr @ 28.8V DC	
Terminal base unit	1734-TB, 1734-TBS, 1734-TOP, or 1734-TOPS	

Self Configurable Modules Environmental Specifications

1734 DC Configurable Input/Output Modules Environmental Specifications

Attribute	Value
Operating temperature	-20...55 °C (-4...131 °F)
Nonoperating temperature	-40...85 °C (-40...185 °F)
Relative humidity	5...95% noncondensing
Operating shock	30 g
Nonoperating shock	50 g
Vibration	5 g at 10...500 Hz
Enclosure type rating	None (open-style)
Mounting type	DIN-rail
Certifications (when product is marked)	CE, C-Tick

Analog and Temperature I/O Modules

The POINT I/O analog and temperature I/O modules support: on-board, channel-level data alarming (four set-points per channel); scaling to engineering units; channel-level diagnostics (electronic bits and LED indicators); and integer format.

Analog and temperature input modules support the following configurable parameters and diagnostics:

- open-wire detection with LED and electronic reporting
- four-alarm and annunciation set-points: low alarm; high alarm; low/low alarm; high/high alarm calibration mode detection and electronic reporting
- under-range detection and electronic reporting
- over-range detection and electronic reporting
- channel signal range and on-board scaling (scaling to any 16-bit integer under-/over-range alarms)
- filter type (notch for A/D, or first-order low-pass digital filter)
- temperature scale (Celsius, Fahrenheit, Kelvin, Rankine, or custom)
- channel update rate (step response plus 0...10,000 ms filter setting)

Choose analog or temperature I/O modules when you need:

- On-board scaling eliminates the need to scale the data in the controller, preserving controller processing time and power for more important tasks, such as I/O control, communications, or other user-driven functions.
- Over- and under-range detections and indications eliminate the need to test values in the control program, saving valuable processing power of the controller.
- Ability to individually configure each channel of the output module to hold its last value or assume a user-defined value on a fault condition.
- Ability to individually enable and disable channels improves module performance.
- Selectable input filters lets you select from several different filter frequencies for each channel that best meets the performance needs of your application based on environmental limitations
- Selectable response to broken input sensor feature provides feedback to the controller that a field device is not connected or operating properly. This lets you specify corrective action based on the bit or channel condition.
- The modules share a high accuracy rating of $\pm 0.1\%$ of full-scale accuracy at 25 °C (77 °F).

Analog Input Modules

1734 Analog Input Modules Technical Specifications

	1734-IE2C	1734-IE2V	1734-IE4C	1734-IE8C
Number of inputs	2		4	8
Input signal range	4...20 mA 0...20 mA	0...10V ±10V	4...20 mA 0...20 mA	4...20 mA 0...20 mA
Input resolution	16 bits - over 21 mA 0.32 µA/cnt	15 bits plus sign 320 µV/cnt in unipolar or bipolar mode	16 bits - 0...21 mA 0.32 µA/cnt	
Data format	Signed integer			
Accuracy	Current Input: 0.1% Full Scale @ 25 °C ⁽¹⁾	Voltage Input: 0.1% Full Scale @ 25 °C ⁽¹⁾	Current Input: 0.1% Full Scale @ 25 °C ⁽¹⁾	
Accuracy drift w/temp.	Current Input: 30 ppm/°C	5 ppm/°C	30 ppm/°C	
Step response, per channel	70 ms @ Notch = 60 Hz (default) 80 ms @ Notch = 50 Hz 16 ms @ Notch = 250 Hz 8 ms @ Notch = 500 Hz		50 ms @ Notch = 60 Hz (default) 60 ms @ Notch = 50 Hz 30 ms @ Notch = 100 Hz 25 ms @ Notch = 120 Hz 15 ms @ Notch = 200 Hz 12.5 ms @ Notch = 240 Hz 10 ms @ Notch = 300 Hz 7.5 ms @ Notch = 400 Hz 6.25 ms @ Notch = 480 Hz	
Input conversion type	Delta Sigma		Sigma Delta	
POINTBus current	75 mA @ 5V DC			
Power dissipation, max	0.6 W @ 28.8V DC	0.75 W @ 28.8V DC	0.6 W @ 28.8V DC	
Thermal dissipation, max	2.0 BTU/hr @ 28.8V DC	2.5 BTU/hr @ 28.8V DC	2.0 BTU/hr @ 28.8V DC	
Keyswitch position	3			
Terminal base unit	1734-TB, 1734-TBS, 1734-TOP, or 1734-TOPS			

⁽¹⁾ Includes offset, gain, non-linearity and repeatability error terms.

Temperature Input Modules

POINT I/O temperature modules can detect and communicate these electronic conditions:

Over-range alarm	<ul style="list-style-type: none"> The channel over-range alarm is set if the input is greater than the maximum temperature (thermocouple or RTD range dependent), millivolt (+75V) or resistance (600 Ω) range value, or above the maximum range of the thermocouple or RTD. The cold-junction compensator has its own over-range alarm. If the CJC temperature goes above 70 °C (158 °F), the over-range alarm is set.
Under-range alarm	<ul style="list-style-type: none"> The channel under-range alarm is set if the input is less than the minimum temperature (thermocouple or RTD range dependent), millivolt (-75 mV) or resistance (10 Ω) range value, or below the minimum range of the thermocouple or RTD. The cold-junction compensator has its own under-range alarm. If the CJC temperature goes below 0 °C (32 °F), the under-range alarm is set.
Level alarm (low-low, low, high, high-high)	<ul style="list-style-type: none"> When the channel input goes below a low alarm or above a high alarm, a bit is set in the data table. All alarm status bits can be read individually or by reading the channel status byte (bits 2...5 for channel 0; bits 10...13 for channel 1). Each channel alarm can be configured individually.
Open-wire alarm	<ul style="list-style-type: none"> The module has the ability to check for a broken or detached wire. In any mode, if a broken/detached lead is detected, the data value is forced to maximum and the over-range alarm is set. Once the alarm is issued, it remains active as long as the input signal is faulted.

Cold-junction Compensation (1734-IT2I only)

When using thermocouples, cold-junction compensation is required at the termination of the thermocouple wire. Cold-junction can be accomplished in three ways:

- Enter an estimated temperature
- Use a 1734-TBCJC mounting base (recommended)
- Use external cold-junction compensators

Entering an estimated temperature is the least accurate way for cold-junction compensation. Using external compensators is the most expensive way, while using the 1734-TBCJC provides the easiest and most accurate method.

An open cold-junction compensator causes the input point to the maximum temperature value for the selected input type. This causes an alarm to be set. Once the alarm is issued, it remains active as long as the input signal is faulted (above maximum).

Set the cold-junction enable bit on the 1734-IT2I module to enable or disable the cold-junction linearization. If enabled, the proper cold-junction compensation value is applied to the selected thermocouple. If disabled, the data (CJ temperature) is still available but is not applied to the input. If the 1734-TBCJC is not available, this parameter should be set to disabled. A cold-junction value can be added using the cold-junction offset parameter.

Noise Filtering (1734-IR2)

You can select the type and amount of noise filtering on each individual channel.

- Notch filter of analog to digital converter
- First-order, low-pass digital filter

Choose the filter that provides you with the update and step response that most closely matches your system requirements.

1734 Analog Temperature Input Modules Technical Specifications

	1734-IR2	1734-IR2E	1734-IT2I
Number of inputs	2 RTD	2 high resolution RTD	2 thermocouple
Input signal range	0...600 Ω	0...220 Ω	± 75 mV
Input resolution	16 bits 9.5 m Ω /cnt 0.03 $^{\circ}$ C/cnt (pt 385 @ 25 $^{\circ}$ C)	16 bits 2.4 m Ω /cnt 0.006 $^{\circ}$ C/cnt (Pt385 @ 25 $^{\circ}$ C)	15 bits + sign 2.5 mV/cnt ⁽¹⁾
Data format	Signed integer		
Thermocouple resolution	—	—	Type B, 30...1820 $^{\circ}$ C (86...3308 $^{\circ}$ F) 3 counts/ $^{\circ}$ C Type C, 0...2315 $^{\circ}$ C (32...4199 $^{\circ}$ F) 6 counts/ $^{\circ}$ C Type E, -270...1000 $^{\circ}$ C (-454...1832 $^{\circ}$ F) 24 counts/ $^{\circ}$ C Type J, -210...1200 $^{\circ}$ C (-454...2192 $^{\circ}$ F) 21 counts/ $^{\circ}$ C Type K, -270...1372 $^{\circ}$ C (-454...2502 $^{\circ}$ F) 13 counts/ $^{\circ}$ C Type N, -270...1300 $^{\circ}$ C (-454...2373 $^{\circ}$ F) 11 counts/ $^{\circ}$ C Type R, -50...1768.1 $^{\circ}$ C (-58...3214 $^{\circ}$ F) 4 counts/ $^{\circ}$ C Type S, -50...1768.1 $^{\circ}$ C (-58...3214 $^{\circ}$ F) 4 counts/ $^{\circ}$ C Type T, -270...400 $^{\circ}$ C (-454...752 $^{\circ}$ F) 15 counts/ $^{\circ}$ C
Cold junction compensation	—	—	Included in 1734-RTBCJC Remote Termination Block
Cold junction compensation range	—	—	0...70 $^{\circ}$ C

1734 Analog Temperature Input Modules Technical Specifications

	1734-IR2	1734-IR2E	1734-IT2I
Accuracy	Current Input: 0.1% Full Scale @ 25 °C Voltage Input: 0.1% Full Scale @ 25 °C		
Input update rate, per module	20 ms @ Notch = 50 Hz 17 ms @ Notch = 60 Hz (default) 10 ms @ Notch = 100 Hz 8 ms @ Notch = 120 Hz 5 ms @ Notch = 200 Hz 4 ms @ Notch = 240 Hz 3 ms @ Notch = 300 Hz 3 ms @ Notch = 400 Hz 2 ms @ Notch = 480 Hz		
Step response, per channel	60 ms @ Notch = 50 Hz 50 ms @ Notch = 60 Hz 30 ms @ Notch = 100 Hz 25 ms @ Notch = 120 Hz 15 ms @ Notch = 200 Hz 13 ms @ Notch = 240 Hz 10 ms @ Notch = 300 Hz 8 ms @ Notch = 400 Hz 6 ms @ Notch = 480 Hz		
Input impedance	—		100 k Ω
Input resistance	—		1 M Ω
Input conversion type	Delta Sigma		
Common mode rejection ratio	120 dB		
Normal mode rejection ratio	-100 dB, -3 dB Notch filter: 13.1 Hz @ Notch = 50 Hz 15.7 Hz @ Notch = 60 Hz 26.2 Hz @ Notch = 100 Hz 31.4 Hz @ Notch = 120 Hz 52.4 Hz @ Notch = 200 Hz 62.9 Hz @ Notch = 240 Hz 78.6 Hz @ Notch = 300 Hz 104.8 Hz @ Notch = 400 Hz 125.7 Hz @ Notch = 380 Hz		-60 dB, -3 dB Notch filter: 13.1 Hz @ Notch = 50 Hz 15.7 Hz @ Notch = 60 Hz 26.2 Hz @ Notch = 100 Hz 31.4 Hz @ Notch = 120 Hz 52.4 Hz @ Notch = 200 Hz 62.9 Hz @ Notch = 240 Hz 78.6 Hz @ Notch = 300 Hz 104.8 Hz @ Notch = 400 Hz 125.7 Hz @ Notch = 380 Hz
Overvoltage protection, inputs	No input protection		Input not overvoltage protected
Input calibration	Factory calibrated		
POINTBus current	220 mA @ 5V DC		175 mA @ 5V DC
Power dissipation, max	1.0 W		
Thermal dissipation, max	3.3 BTU/hr		
Isolation voltage	50V (continuous), Basic Insulation Type Type tested at 2200V DC for 60 s, I/O to system		
External DC supply voltage, nom	24V DC		—
External DC supply voltage range	10...28.8V DC		—

1734 Analog Temperature Input Modules Technical Specifications

	1734-IR2	1734-IR2E	1734-IT2I
External DC supply current, nom	15 mA @ 24V DC		—
Terminal base unit	1734-TB, 1734-TBS, 1734-TOP, or 1734-TOPS		1734-TBCJC
Keyswitch position	6		

⁽¹⁾ Includes offset, gain, non-linearity and repeatability error terms.

Analog Output Modules**1734 Analog Output Modules Technical Specifications**

	1734-OE2C	1734-OE2V	1734-OE4C
Number of outputs	2		4
Output signal range	4...20 mA 0...20 mA	0...10V ±10V	4...20 mA 0...20 mA
Output resolution	13 bits - over 0...21 mA 2.5 µA/cnt	14 bits (13 plus sign) 1.28 mV/cnt in unipolar or bipolar mode	16 bits - over 0...21 mA 2.5 µA/cnt
Data format	Signed integer		
Accuracy	Current output: 0.1% Full Scale @ 25 °C ⁽¹⁾	Voltage output: 0.1% Full Scale @ 25 °C ⁽¹⁾	Current output: 0.1% Full Scale @ 25 °C ⁽¹⁾
Accuracy drift w/temp.	Current output: 30 ppm/°C	Voltage output: 5 ppm/°C	Current output: <50 ppm/°C
Step response to 63% of FS, output	Current output: 24 µs	Voltage output: 20 µs	Current output: 40 µs
Output conversion rate	16 µs	20 µs	1 µs
POINTBus current	75 mA @ 5V DC		
Power dissipation, max	750 Ω load on each output - 1.23W 0 Ω load on each output - 1.83W	1.0W	750 Ω load on each output - 1.86W 0 Ω load on each channel - 2.15W
Thermal dissipation, max	750 Ω load on each output - 4.19 BTU/hr 0 Ω load on each output - 6.24 BTU/hr	3.4 BTU/hr	750 Ω load on each output - 6.34 BTU/hr 0 Ω load on each channel - 7.33 BTU/hr
Terminal base unit	1734-TB, 1734-TBS, 1734-TOP, or 1734-TOPS		
Keyswitch position	4		

⁽¹⁾ Includes offset, gain, non-linearity and repeatability error terms.

Analog and Temperature I/O Modules Environmental Specifications

1734 Analog and Temperature I/O Modules Environmental Specifications

Attribute	Value
Operating temperature	-20...55 °C (-4...131 °F)
Nonoperating temperature	-40...85 °C (-40...185 °F)
Relative humidity	5...95% noncondensing
Operating shock	30 g
Nonoperating shock	50 g
Vibration	5 g @ 10...500 Hz
Enclosure type rating	None (open-style)
Mounting type	DIN Rail
Certifications (when product is marked)	c-UL-us, CE, C-Tick, Ex

Specialty I/O Modules

1734-232ASC and 1734-485ASC Serial Interface Modules

The 1734-232ASC and 1734-485ASC serial interface modules offer a serial-link communication interface solution for peripheral products with RS-232 (use the 1734-232ASC), RS-485, and RS-422 ports (use the 1734-485ASC). These modules allow a device with serial-interface output (for example, bar code readers) to communicate up to 128 bytes of ASCII data onto any network supported by the POINT I/O system. Each module is a single-channel, full-duplex interface and is rated for up to 38.4 Kbps. LED indicators on the modules offer diagnostics for the module, POINTBus backplane, and transmit/receive status indication.

1734 Serial Interface Modules Technical Specifications

	1734-232ASC, 1734-485ASC
Number of serial channels	1
POINTBus current (mA)	75
Power dissipation	0.75 W @ 28.8V DC
Thermal dissipation	2.5 BTU/hr max @ 28.8V DC
Terminal base unit	1734-TB, 1734-TBS, 1734-TOP, or 1734-TOPS
Keyswitch position	2 (specialty)
Serial port parameters	
Serial character framing	7N2, 7E1, 7O1, 8N1, 8N2, 8E1, 8O1, 7E2, 7O2
Serial port comm speed	9600 bps, 1200 bps, 2400 bps, 4800 bps, 19.2 kbps, 38.4 kbps

1734 Serial Interface Modules Technical Specifications

	1734-232ASC, 1734-485ASC
Serial port receive from ASCII device	
Number of receive chars, max	1...128
ReceiverRecord start mode	No, exclude, include start delimiter
Receive start delimiter	ASCII character
Receive record end mode	No, exclude, include end delimiter
Receive end delimiter	ASCII character
Send (produce) on DeviceNet to Master	
Receive string data type	Array, short_string, string
Pad mode	Pad mode disabled, enabled
Pad character	ASCII character
Receive swap mode	Disabled, 16-bit, 24-bit, 32-bit swap
DeviceNet handshake mode	Master/slave handshake, produce immediate
Produce assembly size	4...132
Serial data size	0...128 bytes
Receive transaction ID	0...255
Serial port transmit to ASCII device	
Number of transmit chars, max	1...128
Transmit end delimiter mode	No, exclude, include end delimiter
Transmit end delimiter character	ASCII character
Consume on DeviceNet from Master	
Consume string data type	Array, short_string, string
Transmit swap mode	Disabled, 16-bit, 24-bit, 32-bit swap
DeviceNet record header mode	Transmit handshake/immediate
Consume assembly size	4...132
Serial port transmit/explicit messages from configuration tool	
Transmit serial data string size	0...128 bytes
Transmitted serial data length	0...128 bytes
Transmit transaction ID	0...255
Status	TX FIFO overflow, RX FIFO overflow, RX parity error, handshake error, new data flag

1734-SSI Synchronous Serial Interface Module with Absolute Encoder

The 1734-SSI module collects serial data from industrial absolute-position encoding sensors that use standard SSI protocol. The SSI module is inserted

into a POINT I/O terminal base that provides common power, communications, and wiring connections for the SSI sensors.

1734-SSI Module Technical Specifications

	1734-SSI
Number of SSI channels	1
POINTBus current	110 mA
Power dissipation, max	0.94 W
Thermal dissipation, max	—
Terminal base unit	1734-TB, 1734-TBS, 1734-TOP, or 1734-TOPS
Keyswitch position	2
Isolation voltage	50V (continuous), Basic Insulation Type Type tested at 1250V AC for 60 s, field side to system
External DC supply voltage, nom	10...28.8V DC
Encoder type	Any absolute encoder supporting standard SSI protocol including linear, rotary, and optical distance measuring devices
SSI data rate	125 kHz, 250 kHz, 500 kHz, 1 MHz, 2 MHz (software selectable)
SSI bits per word	2...31 (software selectable)
SSI word length	4 bytes (32 bits)
SSI word delay time	16 μ s...64 ms (software selectable) ⁽¹⁾
SSI features	Gray or binary code capable with gray to binary conversion, increasing or decreasing SSI count indication, 2 SSI word comparator values, SSI word latching with I1 input
SSI cable type	UL CM/AWM 2464/CSA Type CMG FT4 or similar cable utilizing shielded twisted pairs for D \pm and C \pm connections. See sensor manufacturer for actual cable required for the SSI sensor under use. I1 input can be wired separate from SSI cable.
SSI cable length	Depends on desired SSI data rate: 125 kHz...320 m (1050 ft) 250 kHz...160 m (525 ft) 500 kHz...60 m (195 ft) 1 MHz...20 m (65 ft) 2 MHz...8 m (25 ft)
SSI sensor power (at V+/- terminals)	10...28.8V DC common with field power voltage, 0.75A DC maximum with short circuit protection
SSI clock drive current, max (out of C+/- terminals)	750 mA
Input I1 category/type	Similar to IEC Type 3, sourcing
Voltage, on-state input, min	0V DC
Voltage, on-state input, max	Field Power Supply Voltage minus 10V

1734-SSI Module Technical Specifications

	1734-SSI
Current, on-state input, min	2 mA
Current, on-state input, nom	4 mA (Field Power Supply Voltage = 24V DC)
Current, on-state input, max	5 mA
Voltage, off-state input, min	Field Power Supply Voltage minus 5V
Voltage, off-state input, max	Equal to Field Power Supply Voltage
Current, off-state input, max	1.2 mA
Input impedance, nom	3.6 k Ω
Input impedance, max	4.7 k Ω
Input filter time, nom	0.5 ms
Field power supply voltage range	10...28.8V DC

⁽¹⁾ Time between successive SSI words (Tp). Also called Dwell Time.

1734-ARM Address Reserve Module

The 1734-ARM address reserve module reserves address and slot numbers to maintain the numbering schemes of purchased I/O module sets.

Non-parameterized, signal modules' structure and address location are retained when replaced with a signal module. The 1734-ARM has no module configuration and does not communicate I/O data.

1734-ARM Module Technical Specifications

	1734-ARM
POINTBus current (mA)	75
Power dissipation, max	0.375 W @ 5V DC
Thermal dissipation, max	1.3 BTU/hr @ 5V DC
Terminal base unit	1734-TB, 1734-TBS, 1734-TOP, or 1734-TOPS
Keyswitch position	Use the keyswitch position of the removed module

1734-CTM Common Terminal and 1734-VTM Voltage Terminal Modules

The POINT I/O Common Terminal Module (1734-CTM) and Voltage Terminal Module (1734-VTM) provide expansion of the termination capability of POINT I/O. Install the Common and Voltage Terminal Modules on a 1734-TB, 1734-TBS, 1734-TOP, or 1734-TOPS terminal base assembly to

provide support for higher density (8 channel) POINT I/O modules and management of wiring of field devices to the POINT I/O solution.

1734 Terminal Modules Technical Specifications

	1734-CTM	1734-VTM
POINTBus current (mA)	—	
Power dissipation	—	
Thermal dissipation	—	
Terminal base unit	1734-TB, 1734-TBS, 1734-TOP, or 1734-TOPS	
Keyswitch position	5	
Isolation voltage	250V (continuous), Basic Insulation Type Type tested at 1600V DC for 60 s, field-side to system	
Field power supply voltage range	10...28.8V DC, 120/240V AC	
Field power supply current, max	2 A per point, 4 A module	
Terminal base screw torque	Determined by installed terminal block	
Field wiring terminations	0 - Common 1 - Common 2 - Common 3 - Common 4 - Common 5 - Common 6 - Common 7 - Common	0 - Voltage out 1 - Voltage out 2 - Voltage out 3 - Voltage out 4 - Voltage out 5 - Voltage out 6 - Voltage out 7 - Voltage out

Specialty I/O Modules Environmental Specifications

1734 Specialty I/O Modules Environmental Specifications

Attribute	Value
Operating temperature	-20...55°C (-4...131°F)
Nonoperating Temperature	-40...85°C (-40...185°F)
Relative humidity	5...95% noncondensing
Operating shock	30 g
Nonoperating shock	50 g
Vibration	5 g @ 10...500 Hz
Enclosure type rating	None (open-style)
Mounting type	—
Certifications (when product is marked)	c-UL-us

Counter Modules

The POINT I/O counter modules serve as signal conditioners and function blocks (that is, counters) between the customer process signals on the mounting base, and the POINTBus backplane containing the command information. The three main functional blocks are the customer digital I/O interface, the counter ASIC, and the microprocessor.

The counter modules accept feedback from:

- Encoders (either single-ended or differential)
- Pulse generators
- Mechanical limit switches
- Frequencies up to 1 MHz

A filter is available with four settings: 50 Hz, 500 Hz, 5 kHz, 50 kHz. The filter can be turned off to achieve the fastest counting rate.

The modules return the count or frequency in the form of a 24-bit binary number (0...16,777,215) expressed in a 32-bit word. Each counter has a user-selectable preset and rollover value associated with it.

The counter modules operate in the following modes.

- Counter mode — read incoming single-phase pulses, return a binary count.
- Encoder mode — read incoming two-phase quadrature pulses, return a binary count.
- Period/rate mode — count internal clocks during the on period, return a frequency (1734-VHSC24 and 1734-VHSC5 outputs are updated only at the end of the period).
- Continuous/rate mode — count internal clocks during the on period, return a frequency (1734-VHSC24 and 1734-VHSC5 outputs are updated continuously during this period).
- Rate measurement mode — read pulses during the sample period, return a frequency.
- Pulse width modulation (PWM) mode — generate a pulse width modulated signal (1734-VHSC24 and 1734-VHSC5 only).
- Pulse generator mode — generates a pulse of defined width, returns width and quantity of trigger (1734-VHSC24 and 1734-VHSC5 only).

The operation of the counter and encoder modes is nearly identical. The difference between the two modes is in the type of feedback (one-phase versus two-phase) for the count direction (up or down). In encoder mode, a transition is expected on B for counting to proceed in a direction. In counter mode, the

B input may be left at a static level. All operating modes are selected by writing appropriate configuration data to the module.

1734 Incremental Encoder Modules Technical Specifications

	1734-IJ	1734-IK
Number of counters	1	
Input frequency, max	1.0 MHz counter and encoder X1 configurations (no filter) 500 kHz encoder X2 configuration (no filter) 250 kHz encoder X4 configuration (no filter)	
Voltage category/type, input	5V DC A/Areturn, B/Breturn, Z/Zreturn	24V DC A/Areturn, B/Breturn, Z/Zreturn
Current, off-state input, max	≤ 250 mA	≤ 250 mA
Voltage, off-state input, max	≤ 2.5V DC	≤ 8V DC
Current, on-state input, min	≥ 5 mA	
Current, on-state input, max	25.7 mA @ 6V DC 19.1 mA @ 5V DC	6.1 mA @ 15V DC or 10.2 mA @ 24V DC
Voltage, on-state input, min	≥ 2.6V DC	≥ 12.5V DC
Voltage, on-state input, max	≤ 5V DC	Refer to input derating curve
Input filter selections, per A/B/Z group	Off 10 μs (50 kHz) 100 μs (5 kHz) 1.0 ms (500 Hz) 10.0 ms (50 Hz)	
Power dissipation, max	1.1 W @ rated load	1.5 W @ rated load
Thermal dissipation, max	3.75 BTU/hr @ rated load	5.1 BTU/hr @ rated load
Terminal base unit	1734-TB, 1734-TBS, 1734-TOP, or 1734-TOPS	
Keyswitch position	2	
Isolation voltage	50V (continuous), Basic Insulation Type Type tested at 1100V DC for 60 s, field-side to system	
External DC supply voltage, nom	No additional external power required to power module	

1734 VHSC Modules Technical Specifications

	1734-VHSC24	1734-VHSC5
Number of counters	1	
Number of compare windows	4	
Output groups	1 group of 2	
Voltage category/type, input	24V DC	5V DC
Current, off-state input, max	≤ 250 mA	≤ 250 mA
Voltage, off-state input, max	≤ 8V DC	≤ 2.5V DC
Current, on-state input, min	≥ 5 mA	

1734 VHSC Modules Technical Specifications

Current, on-state input, max	10.2 mA @ 24V DC or 6.1 mA @ 15V DC	25.7 mA @ 6V DC 19.1 mA @ 5V DC
Voltage, on-state input, min	≥12.5V DC	≥2.6V DC
Voltage, on-state Input, max	Refer to input derating curve	≥2.6V DC
Input filter selections	Off 10 μs (50 kHz) 100 μs (5 kHz) 1.0 ms (500 Hz) 10.0 ms (50 Hz)	
Input frequency, max	1.0 MHz counter and encoder X1 configurations (no filter) 500 kHz encoder X2 configuration (no filter) 250 kHz encoder X4 configuration (no filter)	
Output delay time off to on	25 μs (load dependent)	
Power dissipation, max	1.9 W @ rated load	1.5 W @ rated load
Thermal dissipation, max	6.5 BTU/hr @ rated load	5.1 BTU/hr @ rated load
Terminal base unit	1734-TB, 1734-TBS, 1734-TOP, or 1734-TOPS	
Keyswitch position	2	
Isolation voltage	50V (continuous), Basic Insulation Type Type tested at 1100V DC for 60 s, field-side to system	
External DC supply voltage, nom	No additional external power required to power module ⁽¹⁾	

⁽¹⁾ Does not represent power required to supply outputs.

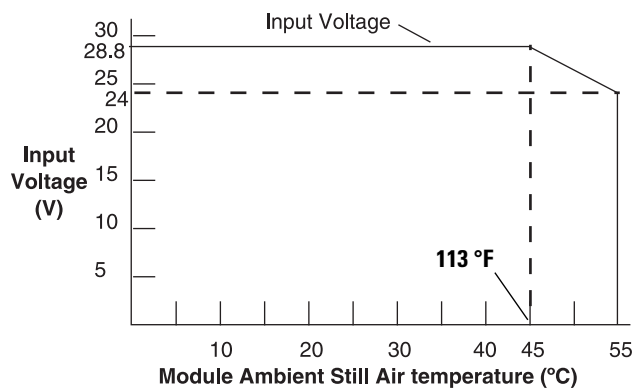
1734-VHSC24 Input Derating Curve

Note: Exceeding the maximum input voltage can cause permanent damage to the input.

Counter Modules Environmental Specifications

1734 Counter Modules Environmental Specifications

Operating temperature	-20...55 °C (-4...131 °F)
Nonoperating Temperature	-40...85 °C (-40...185 °F)
Relative humidity	5...95% non-condensing
Operating shock	30 g
Nonoperating shock	50 g
Vibration	5 g @ 10...500 Hz
Enclosure type rating	None (open-style)
Mounting type	DIN Rail
Certifications (when product is marked)	c-UL-us, CE, C-Tick, Ex

Safety I/O Modules

Use the POINT Guard I/O Safety Modules in the POINT I/O platform to distribute Safety I/O on a GuardLogix, Compact GuardLogix or SmartGuard system. You can configure the modules by using the network configuration tool, RSNetWorx software, or the GuardLogix programming tool, RSLogix 5000 software, version 17 or later.

GuardLogix systems are intended for the use of POINT Guard I/O modules with an EtherNet/IP adapter. SmartGuard systems are intended to use POINT Guard I/O modules with the 1734-PDN module.

Use the modules to construct a safety-control network system that meets the requirements up to Safety Integrity Level 3 (SIL 3) as defined in IEC 61508, Functional Safety of Electrical, Electronic, and Programmable Electronic Safety-related Systems, and the requirements for Safety Category 4 / Performance Level e of the EN ISO 13849-1 standard.

1734-IB8S Technical Specifications

Attribute	Value
Safety Input	
Inputs per module	8
Input type	Current sinking
Voltage, on-state input	11...30V DC
Voltage, off-state input, max	5V DC
Current, on-state input, min	3.3 mA
Current, off-state, max	1.3 mA

1734-IB8S Technical Specifications

Attribute	Value
IEC 61131-2 (input type)	Type 3
Reaction time	<16.2 ms
Pulse Test Output	
Output type	Current sourcing
Number of sources (T0, T1M, T2, T3M)	4
Test output current (each output point)	0.7 A max
Aggregate current of test outputs per module	2.8 A @ 40 °C (104 °F)
1734-IB8S temperature versus current derating for both horizontal and vertical installations	
Residual voltage, max	1.2V
Output leakage current, max	0.1 mA
Short circuit protection	Yes
Current, max (when used to control muting lamp)	25 mA (to avoid fault when used as a muted lamp output)
Current, min (when used to control muting lamp)	5 mA (at which fault indication is generated when used as a muted lamp output)

1734-OB8S - Technical Specifications

Attribute	Value
Safety Output	
Outputs per module	8
Output type	Current sourcing
Output current (each output point), max	1 A
Residual voltage (drop)	<0.6V
Leakage current, max	0.1 mA
Short-circuit detection	Yes (short high and low and cross-circuit fault detect)
Short-circuit protection	Electronic

1734-OB8S - Technical Specifications

Attribute	Value
Aggregate current of outputs per module	8 A (4 A per terminal base) @ 40 °C (104 °F)
1734-OB8S temperature versus current derating for both horizontal and vertical installations	
Reaction time	<6.2 ms

1734-IB8S and 1734-OB8S - Technical Specifications

Attribute	1734-IB8S	1734-OB8S
POINTBus		
POINTBus current, max	175 mA	190 mA
Power dissipation	1.4 W	1.9 W
Thermal dissipation	4.8 BTU/hr	6.5 BTU/hr
Isolation voltage	50V (continuous), Basic Insulation Type between field side and system No isolation between individual channels Type tested at 707V DC for 60 s	
Power bus, operating supply voltage, nom	24V DC	
Power bus, operating voltage range	19.2...28.8V DC	
Input filter time, OFF to ON ⁽¹⁾	0...126 ms (in 6 ms increments)	
Input filter time, ON to OFF ⁽¹⁾		
Terminal base screw torque	See terminal base specifications	
Indicators	1 yellow lock status indicator 1 green/yellow power status indicator 8 I/O channel status indicators	

⁽¹⁾ Input off-to-on filter time is the time from a valid input signal to recognition by the module. Input on-to-off time is the time from a valid input signal to recognition by the module.

1734-IB8S and 1734-OB8S Physical Specifications

Attribute	Value
Keyswitch positions (left and right)	1734-IB8S: Key 1 = 8 (left); Key 2 = 1 (right) 1734-OB8S: Key 1 = 8 (left); Key 2 = 2 (right)
Terminal base unit	1734-TB, 1734-TBS, 1734-TOP, 1734-TOPS, 1734-TOP3, 1734-TOP3S
Pilot duty rating	Not rated (1734-OB8S only)
North America temp code	T4
IEC temp code	T4
Enclosure type rating	None (open-style)
Wiring category ⁽¹⁾	2 - on signal ports
Wire size	Determined by installed terminal block
Weight, approx.	62.4 g (2.2 oz)
Dimensions (HxWxD), approx. (without terminal block)	77 x 25 x 55 mm (3.03 x 0.98 x 2.17 in.)

⁽¹⁾ Use this conductor category information for planning conductor routing. Refer to the Industrial Automation Wiring and Grounding Guidelines, publication [1770-4.1](#).

POINT I/O Accessories*POINT I/O Marker Card*

The POINT I/O Marker Card is available under catalog number 1492-SM5X5. Each kit contains five 12.7 x 12.7 cm (5 x 5 in.) cards with 100 markers per card. You can enter text on the marker cards using different font sizes and text widths; you can print multiple lines on one marker card; you can even print common symbols.

POINTBus Extension Cable

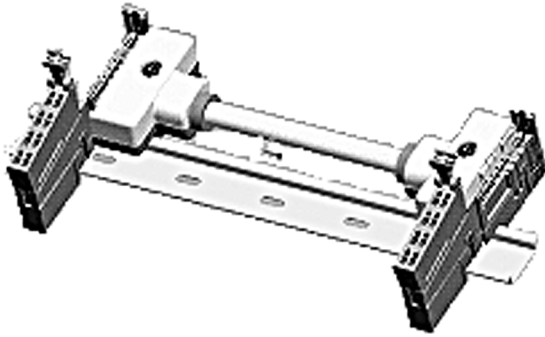

45219

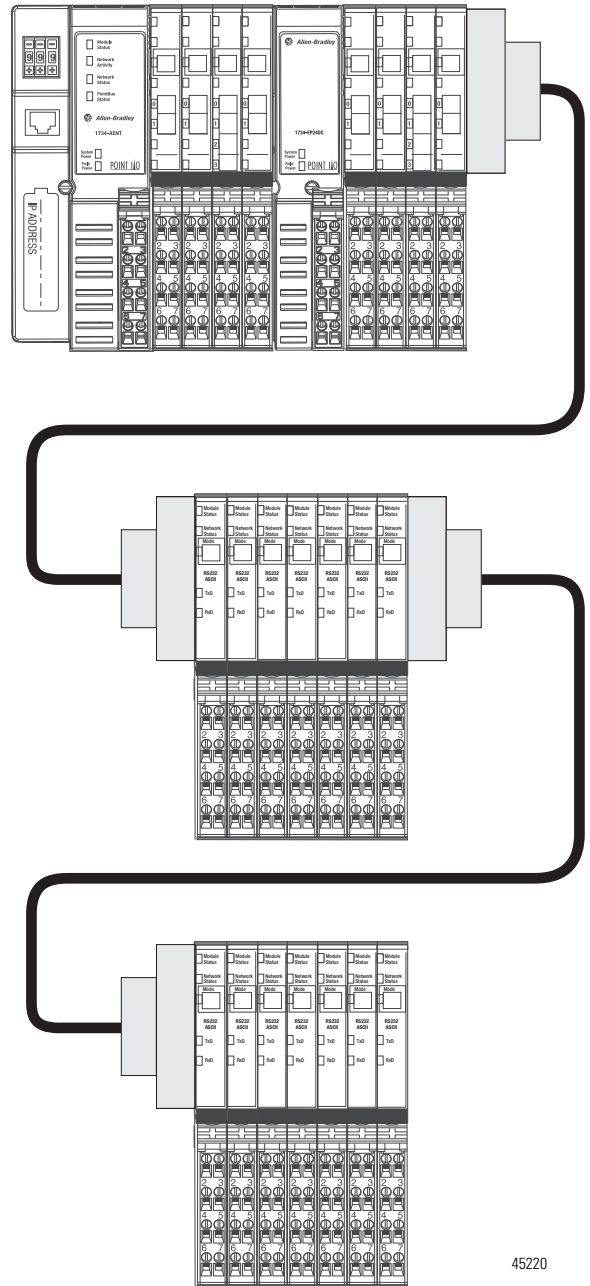

45220

The POINT I/O POINTBus Extension Cable is available in 1 meter and 3 meter lengths as:

- 1734-EXT1; 1 meter extension
- 1734-EXT3; 3 meter extension

Select a Terminal Base Assembly

Step 3 - Select:

- the appropriate terminal base unit for your module

Terminal Base Assembly..... page 47
 One-piece Terminal Bases..... page 49

The POINT I/O system follows a No Tools design approach. The I/O mounting base, removable terminal block (RTB), and I/O module may be assembled as a system without tools.

Terminal Base Assembly

The POINT I/O mounting base mounts directly on the DIN-rail, either vertically or horizontally, and forms the interconnect for the POINTBus backplane communication and field power-bus distribution. The mechanical keying of the mounting base prevents incorrect module placement. The I/O mounting base and removable terminal block are sold together (pre-assembled) as a single unit called a Terminal Base Assembly.

The pins on the 1734-TB terminal base assembly are independent of each other. The connections for the 1734-TB and 1734-TB3 are determined by the 1734 module being used.

Terminal Base Pins

1734-TB, -TBS, -TOP, -TOPS

0	1
2	3
4	5
6	7

45217

1734-TB3, -TB3S, -TOP3, -TOP3S

0	1
2	3
4	5
6	7
8	9
10	11

45218

Pins 4, 5, 8, and 9 are connected together.
 Pins 6, 7, 10, and 11 are connected together.

Each assembly includes a removable terminal block (RTB) provides 8 or 12 separate terminal locations for field wiring. The RTB also provides vertical access to wire and screw terminations. A separate terminal point is provided for each wire, including a shield ground terminal point for 2-point analog modules.

POINT I/O Removable Terminal Base Assembly

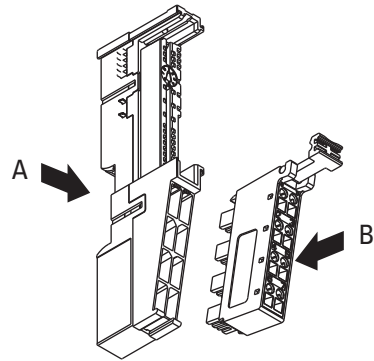

45103

Each terminal base assembly includes a base (A) that mounts onto the DIN-rail and a removable terminal block (B) for I/O wiring.

Once the RTB is wired properly, you never need to rewire terminations. The RTB separates independently of the I/O mounting base and I/O module to facilitate rapid installation and commissioning of the system. Each terminal is numbered on the bottom of the RTB to simplify troubleshooting during commissioning or maintenance cycles. Spare or replacement RTBs can be ordered separate from the terminal base assembly.

Terminal Base Assemblies

Terminal Base Assembly Cat. No.	Description	Terminal Base Screw Torque	Replacement RTB Cat. No.
1734-TB	Mounting base with 8-terminal cage-clamp RTB	0.6 Nm (7 lb-in)	1734-RTB
1734-TBS	Mounting base with 8-terminal spring-clamp RTB		1734-RTBS
1734-TB3	Mounting base with 12-terminal cage-clamp RTB		1734-RTB3
1734-TB3S	Mounting base with 12-terminal spring-clamp RTB		1734-RTB3S
1734-TBCJC ⁽¹⁾	Mounting base with cold-junction compensation RTB	0.5...0.6 Nm (5...7 lb-in)	1734-RTBCJC ⁽¹⁾

⁽¹⁾ For use with the 1734-IT21 thermocouple input module.

One-piece Terminal Bases

The POINT I/O one-piece terminal base is a mounting base with an integrated terminal block.

POINT I/O One-piece Terminal Base

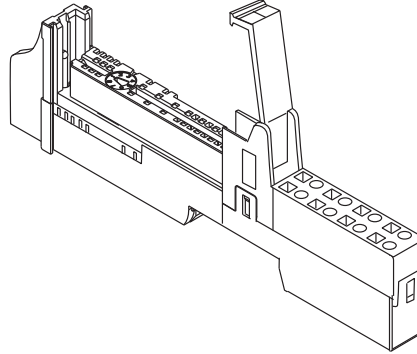

1734 One-piece Terminal Bases

Cat. No.	Description	Terminal Base Screw Torque
1734-TOP	8-terminal screw-clamp terminal base	0.6 Nm (7 lb-in)
1734-TOPS	8-terminal spring-clamp terminal base	
1734-TOP3	12-terminal screw-clamp terminal base	
1734-TOP3S	12-terminal spring-clamp terminal base	

Notes:

Select a Power Supply Unit

Step 4 - Select:

- the appropriate power unit

POINT I/O Communication Adapters page 51
 Expansion Power Supplies page 52
 Field Power Distributor page 56

Power units are divided into three categories:

- Communication adapter with built-in power supply (DC-DC)
- Expansion power supply
- Field power distributor

POINT I/O Communication Adapters

POINT I/O communication adapters have built-in POINTBus power supplies. All POINT I/O modules are powered from the POINTBus backplane by either an adapter or expansion power supply.

1734 Communication Adapters Power Specifications

	1734-AENT(R)	1734-ACNR	1734-PDN 1734D	Series	1734-ADN(X)	1734-APB
Input voltage, nom	24V DC	24V DC	24V DC	10...28.8V DC	24V DC	24V DC
Input voltage range	10...28.8V DC	10...28.8V DC	11...25V DC DeviceNet specification	11...25V DC DeviceNet specification	10...28.8V DC	10...28.8V DC
Field side power requirements	400 mA @ 24V DC (+20% = 28.8V DC)	425 mA @ 24V DC (+20% = 28.8V DC)	400 mA @ 24V DC (+4% = 25V DC)	350 mA @ 24V DC (+4% = 25V DC)	400 mA @ 24V DC (+20% = 28.8V DC)	400 mA @ 24V DC (+20% = 28.8V DC)
Inrush current	6 A for 10 ms	6 A for 10 ms	6 A for 5 ms	6 A for 5 ms	6 A for 10 ms	6 A for 10 ms
POINTBus current (mA)	700 ⁽¹⁾	1000 ⁽²⁾	1300 ⁽³⁾	1000 ⁽²⁾	1000 ⁽²⁾	1000 ⁽²⁾
Power consumption at 24V	4.5 W	8.0 W	8.0 W	8.2 W	8.0 W	8.0 W

1734 Communication Adapters Power Specifications

	1734-AENT(R)	1734-ACNR	1734-PDN 1734D	Series	1734-ADN(X)	1734-APB
Power dissipation, max	2.8 W @ 28.8V	2.8 W @ 28.8V	1.2 W @ 25V	2.0 W @ 24V	2.8 W @ 28.8V	2.8 W @ 28.8V
Input overvoltage protection	Reverse polarity protected					
Interruption	Output voltage will stay within specifications when input drops out for 10 ms at 10V with max load.	—	—	—	Output voltage will stay within specifications when input drops out for 10 ms at 10V with max load.	—

⁽¹⁾ 700 mA when input voltage < 17V DC.

⁽²⁾ 1000 mA @ 5V DC $\pm 5\%$ (4.75...5.25V).

⁽³⁾ 1300 mA @ 5V DC $\pm 5\%$ (4.75...5.25V).

Expansion Power Supplies

The 1734-EP24DC or 1734-EPAC expansion power supplies provides two services:

- Breaks the field power distribution at the left of the power supply (1734-EP24DC or 1734-EPAC) from the field power distribution to the right of the power supply (1734-EP24DC or 1734-EPAC)
- Adds an additional 1.3 A of current to the POINTBus for I/O modules to the right of the power supply (1734-EP24DC or 1734-EPAC)

The expansion power unit maintains the integrity of the POINT I/O backplane by not interrupting the POINTBus data.

The 1734-EP24DC expansion power unit passes 24V DC field power on the POINTBus backplane to the I/O modules to the right of it. The 1734-EPAC expansion power unit passes 120/240V AC field power on the POINTBus backplane to the I/O modules to the right of it. These units extend the backplane bus power and creates a new field voltage partition segment for driving field devices for up to 17 I/O modules. The expansion power units separate field power from I/O modules to the left of the unit, effectively providing functional and logical partitioning for:

- separating field power between input and output modules.
- separating field power to the analog and digital modules.
- grouping modules to perform a specific task or function.

You can use multiple expansion power units with the 1734-ADN, 1734-ADNX, 1734-ACNR, 1734-AENT, and 1734-APB communication adapters to assemble a full system. For instance, if you are using the

1734-ADN adapter, you can use a 1734-EP24DC or 1734-EPAC expansion power unit to add additional modules.

For example, if you have a 36 module system with a 1734-ADN adapter, you have to add at least two or more 1734-EP24DC or 1734-EPAC expansion power units to provide more POINTBus current for modules to the right of the supply.

- 24...5V DC converter (1734-EP24DC)
120/240V AC to 5V DC converter (1734-EPAC)
- 1.3 A, 5V DC output (extend backplane power)
- Starts new voltage distribution
- Partitioning
- Dark-gray color for easy visual inspection and identification

You can use the 1734-EP24DC or 1734-EPAC expansion power supply only with POINT I/O adapters. Do not use it with the 1734-PDN or 1734D series communication interfaces.

1734 Expansion Power Supplies Technical Specifications

	1734-EP24DC	1734-EPAC
Field side power requirements, max	400 mA @ 24V DC (+20% = 28.8V DC max)	200 mA @ 120V AC, 100 mA @ 240V AC
Inrush current, max	6 A for 10 ms	2 A for 6 ms
POINTBus output current rating	Horizontal mounting: 1 A @ 5V DC for 10...19.2V input 1.3 A @ 5V DC for 19.2...28.8V input Vertical mounting: 1 A @ 5V DC for 10...28.8V input	Horizontal DIN rail mounting: 1.3 A @ 5.2V DC Vertical DIN rail mounting: 1.0 A @ 5.2V DC
Overvoltage protection, inputs	Reverse polarity protected	MOV and fuse protected
Powersupply interruption protection	Output voltage will stay within specifications when input drops out for 10 ms at 10V with max load	Output voltage will stay within specifications when input drops out for 10 ms at 85V with max load
Power supply input voltage, nom	24V DC	120/240V AC
Operating voltage range	10...28.8V DC	85...264V AC
Power consumption, max	9.8 W @ 28.8V DC	15.1 W @ 264V AC
Power dissipation, max	3.0 W @ 28.8V DC	8.4 W @ 264V AC
Thermal dissipation, max	10.0 BTU/hr @ 28.8V DC	28.7 BTU/hr @ 264V AC

1734 Expansion Power Supplies Technical Specifications

	1734-EP24DC	1734-EPAC
Isolation voltage	50V (continuous), Basic Insulation Type Type tested at 2600V DC for 60 s, User power to system, User power to Chassis ground, system to Chassis ground	264V (continuous), Reinforced Insulation Type Type tested at 3250V DC for 60 s, User power to system
Field power supply voltage range	10...28.8V DC	120...240V AC
Field power supply current, max	10 A	10 A

1734-EP24DC Current Derating for Mounting

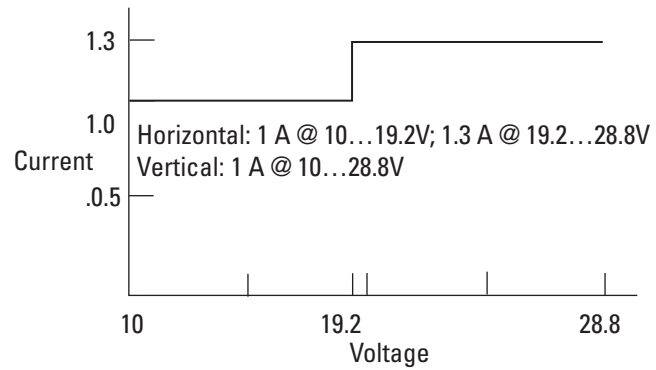

1734-EPAC Current Derating for Mounting

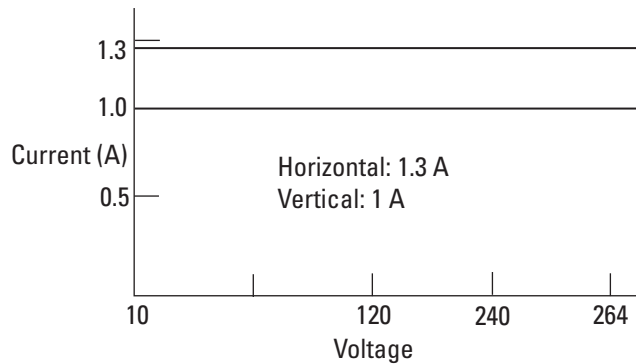

Example of Continuing Power to Field Devices

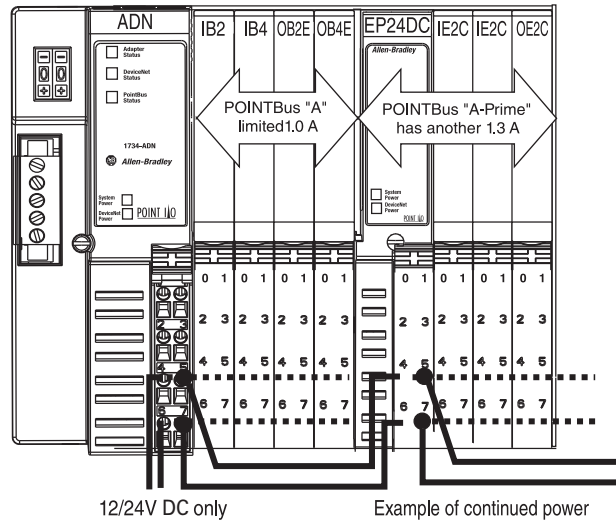

Example of Logical Partitioning

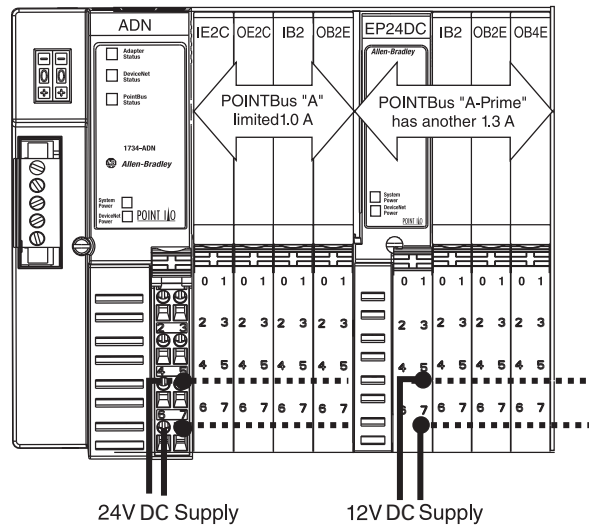

Example of Functional Partitioning

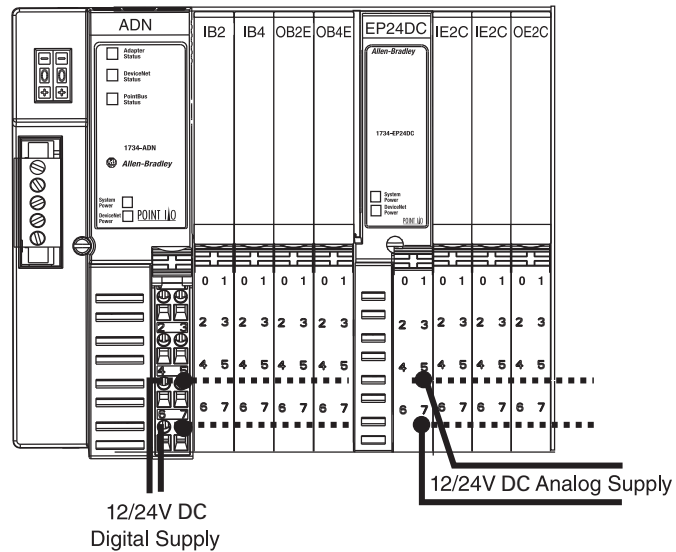

Field Power Distributor

The 1734-FPD breaks the field power distribution at the left of the 1734-FPD from the field power distribution to the right of the 1734-FPD.

You can use the 1734-FPD field power distributor with a broad range of voltage inputs including 5...125V DC and 24...240V AC applications and I/O modules.

- Field-side voltage distribution module
- AC or DC input
- For use with all communication interfaces
- Partitioning (auxiliary power, major motion, or minor motion)
- Starts new voltage distribution point
- No backplane bus power extension (12 modules maximum) when using the 1734-PDN communication interface or 1734D POINTBlock I/O modules as they don't add power to the POINTBus backplane

The 1734-FPD field power distributor passes through all POINT I/O backplane signals, but does not provide additional POINTBus backplane power. The field power distributor gives you the ability to change the field power distribution source for I/O modules to the right of the 1734-FPD field power distributor. This facilitates logical or functional partitioning of low-channel count, high I/O-mix applications using any of the communication adapters.

Use the 1734-FPD field power distributor to isolate field power segments.

1734-FPD Technical Specifications

	1734-FPD
Field side power requirements, max	—
Inrush current, max	—
POINTBus output current rating	—
Overvoltage protection, inputs	—
Power supply interruption protection	—
Power supply input voltage, nom	12V/24V DC 120V/220V AC
Operating voltage range	10...28.8V DC 120V/240V AC
Power consumption, max	—
Power dissipation, max	—
Thermal dissipation, max	—
Isolation voltage	250V (continuous), Basic Insulation Type Type tested at 2600V DC for 60 s, User power to system, User power to Chassis ground, system to Chassis ground
Field power supply voltage range	10...28.8V DC, 120...264V AC
Field power supply current, max	10 A

Wiring Using a 1734-FPD to Create a New AC Device Power Bus

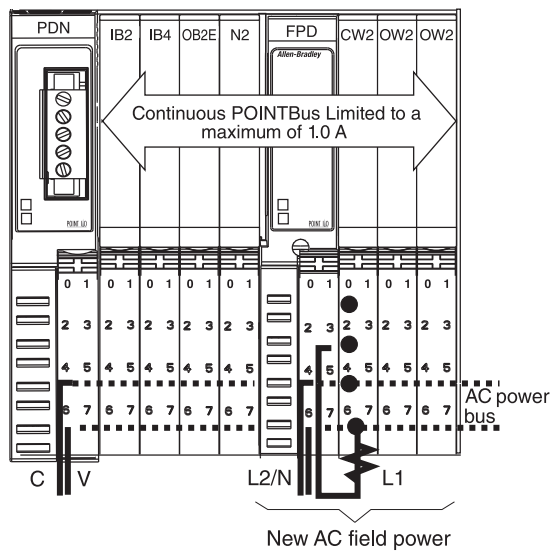

Wiring Using a 1734-FPD to Create a New Analog Device Power Bus

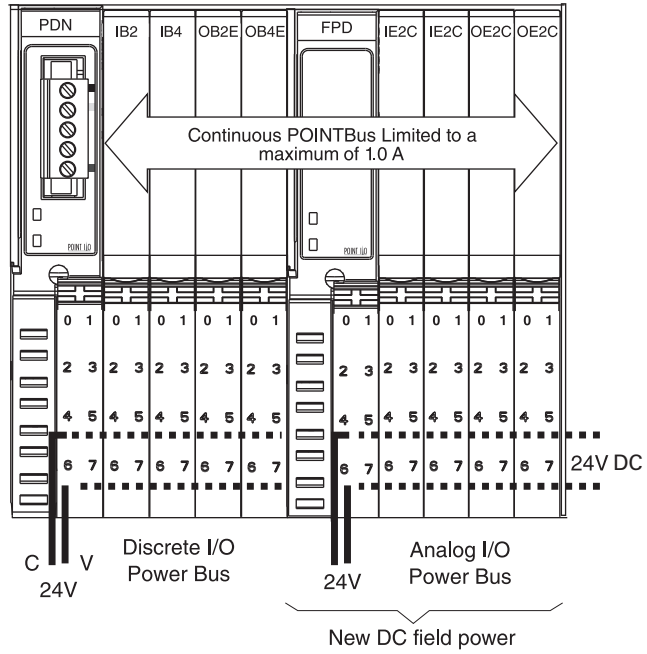

Wiring Using a 1734-FPD to Create a New DC Device Power Bus

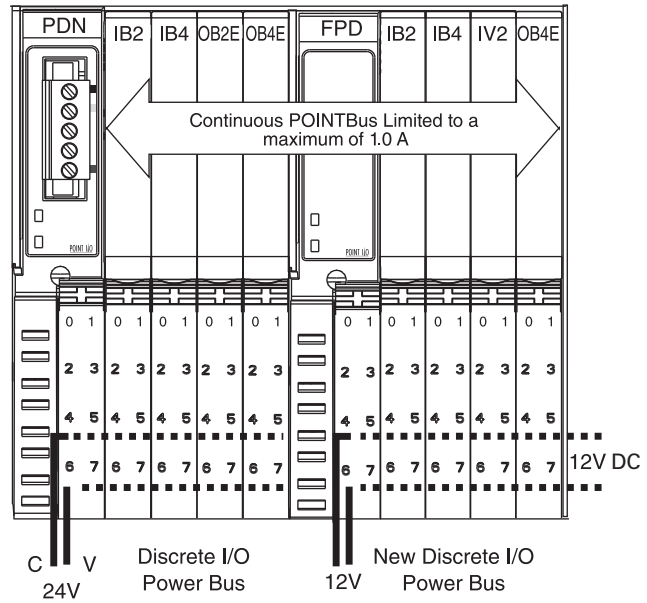

Mounting Requirements

Step 5 - Select:

- appropriate number of DIN rails based on the number of modules and the physical requirements

Power Supply Distance Rating page 59

Mount the POINT I/O System..... page 60

The producer/consumer model multicasts messages. This means that multiple nodes can consume the same data at the same time from a single device.

Where you place POINT I/O modules in the control system determines how the modules exchange data.

For a Rockwell Automation controller to control 1734 I/O, the I/O must be on one of the following:

- the same network as the controller.
- a ControlNet network that is local to that controller.
- an EtherNet/IP network that is local to that controller.

Power Supply Distance Rating

Place modules to the right of the power supply. Each 1734 I/O module can be placed in any of the slots right of the power supply until the usable backplane current of that supply has been exhausted. An adapter provides 1000 mA current to the POINTBus backplane. The 1734-EP24DC or 1734-EPAC Expansion power supply provides up to 1300 mA. I/O modules require from 75 mA (typical for the digital and analog I/O modules) up to 220 mA or more.

Use the following table to plan the maximum size layout of your POINT I/O system.

Maximum Size Layout

	POINTBus current	No. of I/O Modules with 24V DC Backplane Current (@ 75 mA each), max	No. of I/O Modules with Expansion Power Supplies, max	No. of I/O Module Connections, max
1734-PDN on DeviceNet network	1300 mA	Up to 17	Expansion power supply not allowed	Not to exceed scanner capacity
1734D POINTBlock on DeviceNet network	1000 mA	Up to 13	Expansion power supply not allowed	Not to exceed scanner capacity
1734-ADN(X) on DeviceNet network	1000 mA	Up to 13	63	Not to exceed scanner capacity
1734-ACNR on ControlNet network	1000 mA	Up to 13	63	5 rack and 20 direct
1734-AENT on EtherNet/IP network	1000 mA	Up to 13	63	20 total connections including rack and direct
1734-APB on PROFIBUS network	1000 mA	Up to 13	63	Not to exceed scanner capacity
1734-EP24DC Expansion Power	Horizontal mounting: 1000 mA @ 5V DC for 10...19.2V 1300 mA @ 5V DC for 19.2...28.8V	Up to 17	63	Not to exceed scanner capacity
	Vertical mounting: 1000 mA @ 5V DC for 10...28.8V	Up to 17	63	Not to exceed scanner capacity
1734-EPAC Expansion Power	Horizontal mounting: 1300 mA @ 5.2V DC	Up to 17	63	Not to exceed scanner capacity
	Vertical mounting: 1000 MA @ 5.2V DC	Up to 17	63	Not to exceed scanner capacity

Mount the POINT I/O System

Mount the POINT I/O system on a DIN rail in the horizontal or vertical orientation. Use steel, 35 x 75.5 mm DIN rails (cat. no. 199-DR1; 46277-3; EN 50022). The DIN rails for all POINT I/O system components must be mounted on a common, conductive surface to ensure proper electro-magnetic interference (EMI) performance. Secure DIN rail approximately every 200 mm (7.87 in).

Approximate Mounting Dimensions

POINT I/O with 1734-PDN Mounting Dimensions

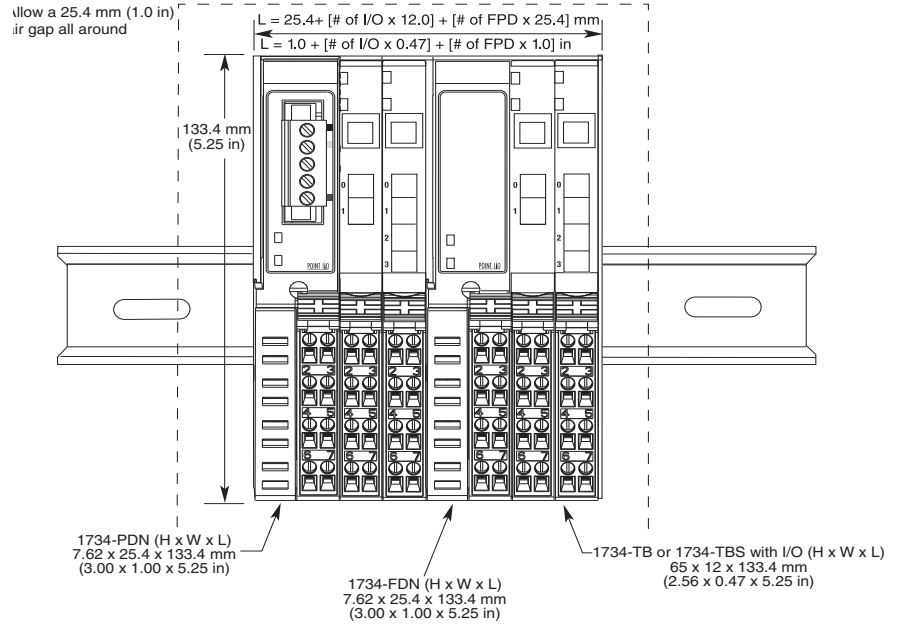

1734D POINTBlock Mounting Dimensions

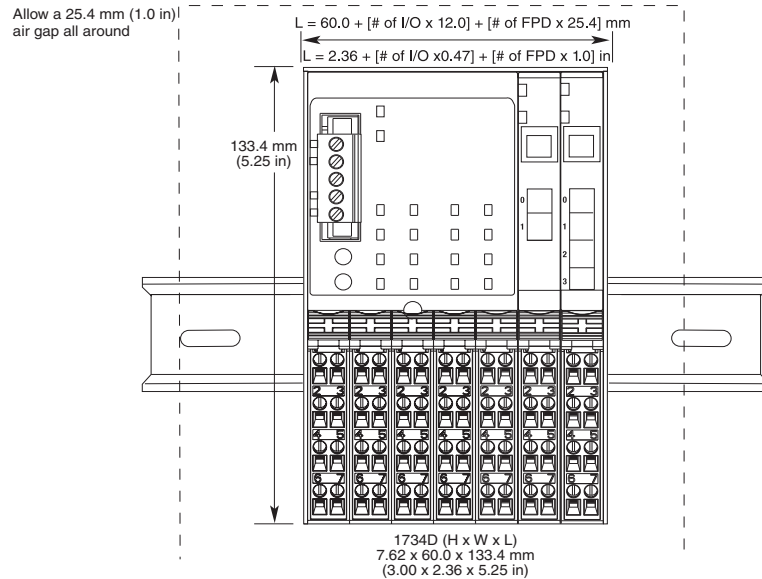

POINT I/O with 1734-ADN(X), 1734-ACNR, 1734-AENT, 1734-APB Mounting Dimensions

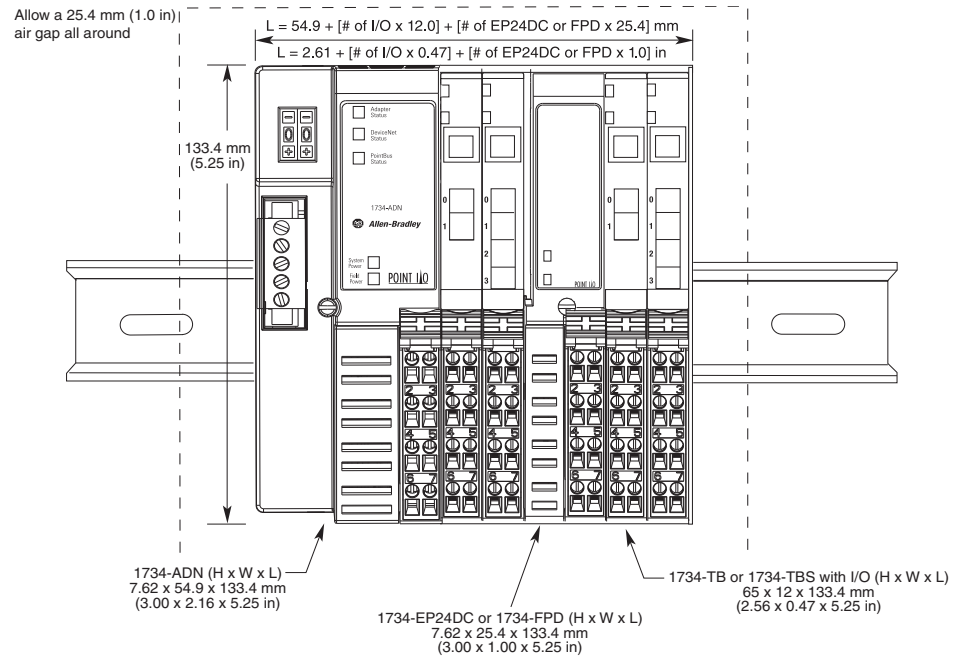

Related Documentation

These documents contain additional information concerning related Rockwell Automation products.

You can view or download publications at <http://literature.rockwellautomation.com>. To order paper copies of technical documentation, contact your local Rockwell Automation distributor or sales representative.

	Cat. No.	Description
General Information		DeviceNet Media (Media, Sensors and Distributed I/O) Catalog Guide
		DeviceNet Adapter Quick Start
		ControlNet Media
		EtherNet/IP Performance and Application Guide
		Industrial Automation Wiring and Grounding Guidelines
		Allen-Bradley Terminal Marking System Product Profile
Communication Interfaces	1734-ADN(X)	POINT I/O DeviceNet Adapter Module Installation Instructions, publication 1734-IN026 POINT I/O DeviceNet Adapter Module User Manual, publication 1734-UM002
	1734-PDN	POINT I/O DeviceNet Communication Interface Module Installation Instructions, publication 1734-IN057
	1734-AENT	POINT I/O Ethernet Adapter Installation Instructions, publication 1734-IN590 POINT I/O EtherNet/IP Communication Adapter Module User Manual, publication 1734-UM010
	1734-AENTR	POINT I/O 2 Port EtherNet/IP Adapter Installation Instructions, publication 1734-IN040 POINT I/O 2 Port EtherNet/IP Adapter Installation Instructions, publication 1734-UM014
	1734-ACNR	POINT I/O ControlNet Adapter Installation Instructions, publication 1734-IN582 POINT I/O ControlNet Adapter User Manual, publication 1734-UM008
	1734-APB	POINT I/O PROFIBUS Adapter Module Installation Instructions, publication 1734-IN014 POINT I/O PROFIBUS Adapter Module User Manual, publication 1734-UM005
Digital and Analog	1734 Series	POINT I/O Digital and Analog Modules User Manual, publication 1734-UM001
AC	1734-IA2 1734-IA4	120V AC 2 Input Module Installation Instructions, publication 1734-IN010
	1734-IM2 1734-IM4	220V AC 2 Input Module Installation Instructions, publication 1734-IN008
	1734-OA2 1734-OA4	120/220V AC 2 Output Module Installation Instructions, publication 1734-IN009

	Cat. No.	Description
DC	1734-IB2 1734-IB4 1734-IB8	24V DC 2, 4, or 8 Input Sink Module Installation Instructions, publication 1734-IN051
	1734-IB4D	POINT I/O 24V DC 4-Channel Discrete Input Module Installation Instructions, publication 1734-IN029
	1734-IV2 1734-IV4 1734-IV8	24V DC 2, 4, or 8 Input Source Module Installation Instructions, publication 1734-IN052
	1734-OB2E 1734-OB4E 1734-OB8E	POINT I/O Protected Output Module Installation Instructions, publication 1734-IN056
	1734-OB2EP	POINT I/O Protected Output Module Installation Instructions, publication 1734-IN586
	1734-OB2 1734-OB4 1734-OB8	POINT I/O Protected Output Module Installation Instructions, publication 1734-IN018
	1734-OV2E 1734-OV4E 1734-OV8E	POINT I/O Protected Sink Output Module Installation Instructions, publication 1734-IN585
Analog	1734-IE2C 1734-IE2V	POINT I/O 2 Current and 2 Voltage Input Analog Modules Installation Instructions, publication 1734-IN027
	1734-IE4C	POINT I/O 4 Channel High Density Current Input Module Installation Instructions publication 1734-IN032
	1734-IE8C	POINT I/O 8 Channel High Density Current Input Module Installation Instructions publication 1734-IN033
	1734-OE2C 1734-OE2V	24V DC Analog 2 Channel Current Output Module Installation Instructions, publication 1734-IN002
	1734-OE4C	POINT I/O 4 Channel Analog Current Output Module Installation Instructions, publication 1734-IN034
	1734-IR2 1734-IR2E 1734-IT2I	POINT I/O RTD and Isolated Thermocouple Input Modules Installation Instructions, publication 1734-IN011
Serial Interface Modules	1734-232ASC/ 1734-485ASC	RS-232, -422, and -485 ASCII Modules Installation Instructions, publication 1734-IN388 RS-232, -422, and -485 ASCII Modules User Manual, publication 1734-UM009
	1734-SSI	Synchronous Serial Interface Module with Absolute Encoder Installation Instructions, publication 1734-IN581 Synchronous Serial Interface Module with Absolute Encoder User Manual, publication 1734-UM007
	1734-IK 1734-IJ	5V and 24V Encoder/Counter Modules Installation Instructions, publication 1734-IN005 5V and 24V Encoder/Counter Module User Manual, publication 1734-UM006
	1734-VHSC5 1734-VHSC24	5V and 24V DC Very High Speed Counter Module Installation Instructions, publication 1734-IN003 5V and 24V DC Very High Speed Counter Module User Manual, publication 1734-UM003

	Cat. No.	Description
Bases	1734-TB, 1734-TBS	Wiring Base Assembly with 8 Point Cage-Clamp Removable Terminal Block Installation Instructions, publication 1734-IN511
	1734-TBS, 1734-TB3S, 1734-RTBS, 1734-RTB3S	Wiring Base Assembly with 12 Point Cage-Clamp Removable Terminal Block Installation Instructions, publication 1734-IN013
	1734-TOP, 1734-TOPS, 1734-TOP3, 1734-TOP3S	POINT I/O One-piece Terminal Bases Installation Instructions, publication 1734-IN028
	1734-TBCJC	Cold Junction Compensation Wiring Base Assembly Installation Instructions, publication 1734-IN583
Power Units	1734-FPD	Field Potential Distributor Module Installation Instructions, publication 1734-IN059
	1734-EP24DC	24V DC Expansion Power Supply Installation Instructions, publication 1734-IN058
	1734-EPAC	120/240V AC Expansion Power Supply Installation Instructions, publication 1734-IN017
Safety	1734-IB8S, 1734-OB8S	POINT Guard I/O Safety Modules Installation and User Manual, publication 1734-UM013

Notes:

Rockwell Automation Support

Rockwell Automation provides technical information on the Web to assist you in using its products.

At <http://www.rockwellautomation.com/support/>, you can find technical manuals, a knowledge base of FAQs, technical and application notes, sample code and links to software service packs, and a MySupport feature that you can customize to make the best use of these tools.

For an additional level of technical phone support for installation, configuration, and troubleshooting, we offer TechConnect support programs. For more information, contact your local distributor or Rockwell Automation representative, or visit <http://www.rockwellautomation.com/support/>.

Installation Assistance

If you experience a problem within the first 24 hours of installation, review the information that is contained in this manual. You can contact Customer Support for initial help in getting your product up and running.

United States or Canada	1.440.646.3434
Outside United States or Canada	Use the Worldwide Locator at http://www.rockwellautomation.com/support/americas/phone_en.html , or contact your local Rockwell Automation representative.

New Product Satisfaction Return

Rockwell Automation tests all of its products to ensure that they are fully operational when shipped from the manufacturing facility. However, if your product is not functioning and needs to be returned, follow these procedures.

United States	Contact your distributor. You must provide a Customer Support case number (call the phone number above to obtain one) to your distributor to complete the return process.
Outside United States	Please contact your local Rockwell Automation representative for the return procedure.

Documentation Feedback

Your comments will help us serve your documentation needs better. If you have any suggestions on how to improve this document, complete this form, publication [RA-DU002](#), available at <http://www.rockwellautomation.com/literature/>.

Rockwell Otomasyon Ticaret A.Ş., Kar Plaza İş Merkezi E Blok Kat:6 34752 İçerenköy, İstanbul, Tel: +90 (216) 5698400

www.rockwellautomation.com

Power, Control and Information Solutions Headquarters

Americas: Rockwell Automation, 1201 South Second Street, Milwaukee, WI 53204-2496 USA, Tel: (1) 414.382.2000, Fax: (1) 414.382.4444

Europe/Middle East/Africa: Rockwell Automation NV, Pegasus Park, De Kleetlaan 12a, 1831 Diegem, Belgium, Tel: (32) 2 663 0600, Fax: (32) 2 663 0640

Asia Pacific: Rockwell Automation, Level 14, Core F, Cyberport 3, 100 Cyberport Road, Hong Kong, Tel: (852) 2887 4788, Fax: (852) 2508 1846