

FPM-3170

Industrial 17" Flat Panel Monitor with VGA/DVI-D/Video/S-Video Port



Features

- 17" SXGA TFT LCD with resolution up to 1280 X 1024
- Stainless steel chassis with NEMA4/IP65-compliant aluminum front panel
- Multi-scan function supports SXGA, XGA, SVGA, VGA, text mode
- High luminance up to 250 cd/m²
- Auto-recognition of input signal
- Supports panel, wall, rack mount or VESA arm
- Multi-signal input supports VGA, DVI-D, Video and S-Video

Introduction

The FPM-3170 is a 17-inch color TFT LCD flat panel monitor specifically designed for industrial applications. With a viewing size as large as 17", it presents an ample display area as well as vivid and sharp images for your HMI. The FPM-3170 features multi-signal input to support VGA, DVI-D, Video and S-Video. You can thus upgrade the display without making changes to the existing system. Its on-screen display function also makes it easy to adjust the images on screen. The whole chassis is designed in stainless steel and the front panel is made of aluminum with NEMA4/IP65 compliance.

Specifications

- **Front Panel** Aluminum, NEMA4/IP65 compliant
- **Mounting** Panel, Wall, rack mount or VESA arm
- **Dimensions (W x H x D)** 482 x 354 x 68 mm (19" x 13.9" x 2.7")
- **Gross Weight** 13.5 Kg (29.8 lbs)
- **I/O Port** VGA, DVI, Video, S-Video, DC power input, power switch, and RS-232 port (Touchscreen version only)
- **Control** OSD (on screen display) control pads on the front panel
- **Power** External 48 W power adapter, with AC 100 V ~ 230 V input and DC +12 V @ 4 A output
- **Operating Temperature** 0 ~ 50° C (32 ~ 122° F)
- **Storage Temperature** -20 ~ 60° C (-4 ~ 140° F)
- **Storage Humidity** 5 ~ 95% non-condensing
- **Vibration (operating)** 5 ~ 17 Hz, double-amplitude displacement 17 ~ 500 Hz, 1.0 G peak to peak
- **CE, FCC, BSMI, and CCC compliant**

LCD Display

- **Display Type** SXGA TFT LCD
- **Display Size** 17"
- **Max. Colors** Full color (16.7 million)
- **Max. Resolution** 1280 x 1024
- **View Angle** 170° (H), 170° (V)
- **Luminance** 250 cd/m² 4 CCFL
- **Storage Temperature** -20 ~ 60° C (-4 ~ 140° F)
- **Operating Temperature** 0 ~ 50° C (32 ~ 122° F)
- **Backlight Lifetime** 50,000 hrs
- **Contrast Ratio** 500:1 (typ.)

Touchscreen (Optional)

- **Type** 8 wire, analog resistive
- **Resolution** Continuous
- **Light Transmission** 72%
- **Controller** RS-232 interface
- **Power Consumption** +5 V @ 200 mA
- **OS Support** Windows 2000/XP
- **Lifespan** 100 million touches

Ordering Information

- **FPM-3170G** Industrial 17" TFT LCD display with 19" Rack-Mount Bezel, VGA/ DVI/ Video interface and AC 100-230 V input 48W power adapter
- **FPM-3170G-R** FPM-3170G with analog resistive touchscreen (RS-232 interface)
- **9689000355** RS-232/485 converter for T/S (USA)
- **9689000356** RS-232/485 converter for T/S (UK)
- **9689000357** RS-232/485 converter for T/S (FR)

Dimensions

Unit: mm

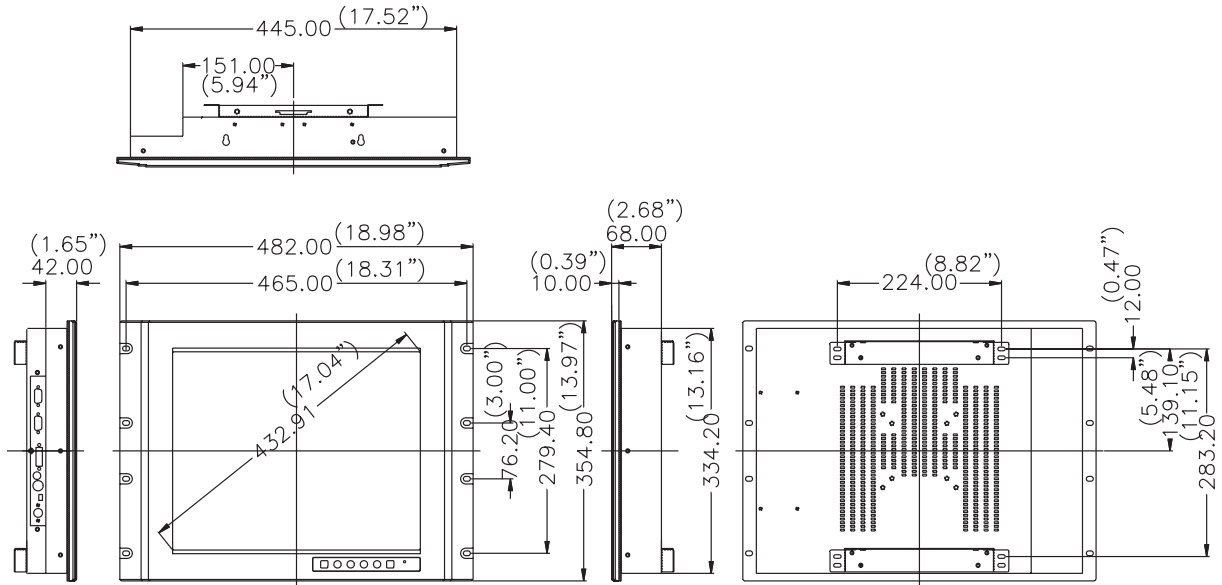

Cut-out dimension: 451 x 340 mm (17.8" x 13.4")

Side View

