

NPN240

Dual NVIDIA GT240 Multiprocessor

Features

OpenVPX

- 6U Rugged VITA46/VITA48 REDI

GPUs

- Two NVIDIA GT240 96 core GPUs
- 1 Gigabyte DDR3 SDRAM per GPU

Expansion plane

- PCIe gen 2

Performance

- 750 GFLOPS @ 80 watts

Note: Requires a suitable Intel® host SBC. Actual performance is application dependent.

Software

- NVIDIA CUDA™, OpenCL™, OpenGL
- AXISLIB VSIPL Math & DSP libraries
- NVIDIA PureVideo® Technology
- NVIDIA PhysX™
- Microsoft® DirectX (Compute)
- MATLAB®

NPN240 is the world's first rugged, NVIDIA CUDA enabled dual GPU multiprocessor for defense and aerospace applications.

Designed for use with our market-leading Intel host SBCs and the IPN250 GPGPU multiprocessor, this platform brings game changing size, weight and power (SWaP) to a wide range of the most demanding deployed computing applications such as radar, sonar, sensor, video and image processing.

General Purpose computing on Graphics Processing Units (GPGPU) lets programmers solve problems in software that previously required dedicated FPGAs or ASICs.

With NPN240 and a suitable host processor card such as SBC620 or IPN250, system integrators can greatly accelerate development while reducing cost and risk by leveraging the skills of a broad community of SW engineers across an expanding

landscape of application development environments such as CUDA, OpenCL, OpenGL and MATLAB.

Multi-GPU clusters are possible linking one or more NPN240s to suitable OpenVPX host processor cards providing the flexibility to support real-time performance for a range of mission requirements at a fraction of the SWaP of conventional systems.

Building on more than 40 years experience supplying COTS boards to worldwide defense OEMs and integrators, GE's new family of GPGPU platforms provide state-of-the-art performance for DSP, general purpose, image and video processing by combining the latest CPUs from Intel's embedded road map with the very latest NVIDIA GPUs in one rugged board level module.

NPN240 is the ideal 6U VPX GPU payload coprocessor for use with a range of OpenVPX Intel host SBCs.



NPN240 – Dual NVIDIA GT240 Multiprocessor

Specifications

Two Graphics Processing Units

- NVIDIA GT240 96 core GPUs
- 1 Gigabyte 128 bit wide DDR3 SDRAM per node
- 1302 MHz shader, 790 MHz Memory, 540 MHz graphics

PCIe gen 2 interfaces

- P2 expansion plane: 2 x8 PCIe ports
- User I/O: 2 x8 PCIe ports

I/O from nodes A & B

- Dual Link DVI, HDMI or Single Link DVI, 2 x VGA

Form Factors

- 6U OpenVPX air, spray and conduction cooled builds
- 6U VITA48 REDI for 2LM

Ruggedization

- Air Cooled levels 1, 2 & 3
- Spray Cooled level 6
- Conduction Cooled levels 4 & 5

OpenVPX

- SLT6-PAY-4F1Q2U2T-10.2.1
- MOD6-PAY-4F1Q2U2T-12.2.1-

Block Diagram

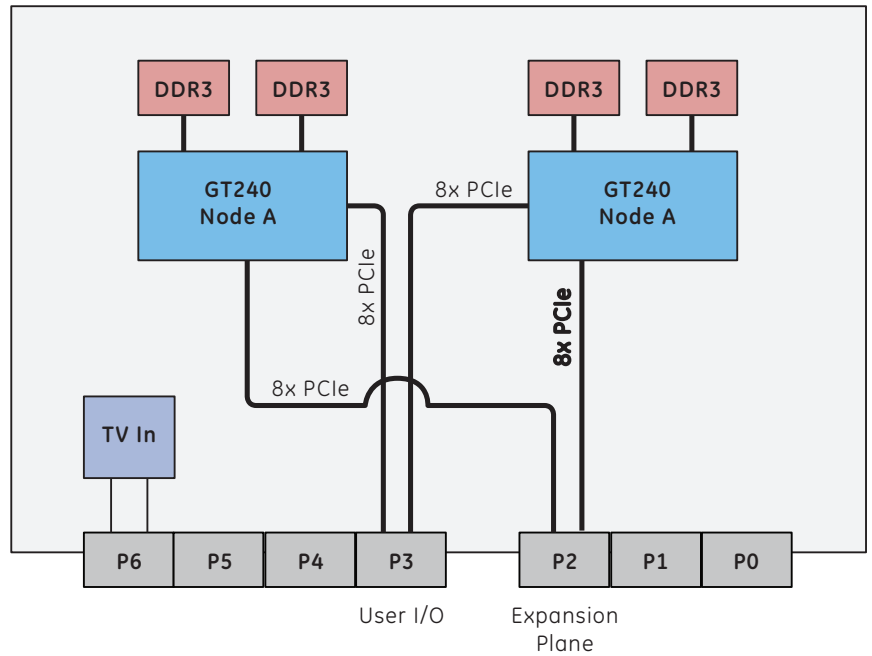

Ordering Information

NPN240 - 1 0 0 0 1 3 = standard

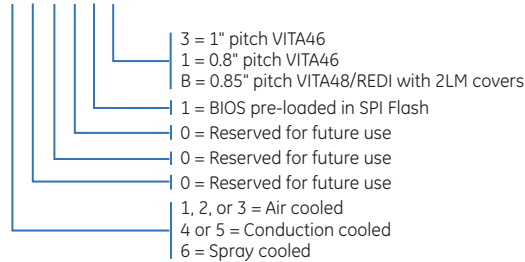

About GE Intelligent Platforms

GE Intelligent Platforms, a General Electric Company (NYSE: GE), is an experienced high-performance technology company and a global provider of hardware, software, services, and expertise in automation and embedded computing. We offer a unique foundation of agile, advanced and ultra-reliable technology that provides customers a sustainable advantage in the industries they serve, including energy, water, consumer packaged goods, government and defense, and telecommunications. GE Intelligent Platforms is a worldwide company headquartered in Charlottesville, VA and is part of GE Enterprise Solutions. For more information, visit www.ge-ip.com.

GE Intelligent Platforms Contact Information

Americas: 1 800 433 2682 or 1 434 978 5100

Global regional phone numbers are listed by location on our web site at www.ge-ip.com/contact

www.ge-ip.com

