

Description

These Filters and chokes are designed to reduce input interference and/or output ripple voltages occurring in applications with switched mode power supplies. Since all our filters contain a Moly Permalloy Powder (MPP) ring core they feature very low DC losses as well as high DC magnetisation and operate perfectly at the input and/or output of switching regulators ensuring effective filtering even at elevated DC current levels. These special characteristics allow the chokes to be operated at DC currents which considerably exceed the rated current, by accepting a corresponding gradual loss of inductance (unlike ferrite core chokes where inductance rapidly decreases above a certain DC magnetising level).

In applications where switching regulators have long supply lines, filters and chokes are used in order to prevent oscillations caused by their negative input impedance. For further information refer also to switching regulator data for "Option L", and to section: *Technical Information: Installation & Application*.



Table 1a: Type survey of FP filter blocks

Filter type Part No.	Matching switching regulator type
FP38	PSR 54 PSA 55 PSA 5A2 PSA 5A5 PSA 123 PSA 153
FP80	PSR 53 PSR 122.5 PSR 152.5 PSR 242 PSR 362 PSA 242.5
FP144	PSA 121.5 PSA 151.5 PSA 241.5 PSA 361 PSA 481

Table 1b: Type survey ring core chokes

Type Part No.	Inductivity	I_{Ln}	Single coil	Symm. coil
LP34-3	34 μ H	3 A	•	
L20-7	20 μ H	7 A	•	
LP20-7	20 μ H	7 A	•	
LP183	2 ∞ 183 μ H	8 A		•

Filter Blocks FP Types

The filter blocks contain, in addition to a MPP ring core, a capacitor and an attenuation resistor, capable of handling the high ripple currents seen at the input of switching regulators. This forms a complete external filter system optimised to prevent oscillations and to reduce superimposed

interference voltages and currents, specially designed for use in PCB applications together with switching regulators in an A01 case size. For selection of filters refer to the type survey.

Table of Contents

	Page		Page
Description	1	Low-Loss Ring Core Chokes L/LP-Series	3
Filter Blocks FP Types	1	Mechanical Dimensions	5

Electrical Data Filter Blocks

General Condition: $T_A = 25^\circ\text{C}$ unless otherwise specified

Table 2: Filter blocks FP

Characteristics		Conditions	FP38			FP80			FP144			Unit
			min	typ	max	min	typ	max	min	typ	max	
I_{Fn}	Rated current	$L = 0.75 L_0$	4			4			2			A DC
U_{Fn}	Rated voltage	$T_{C \text{ min}} \dots T_{C \text{ max}}$	5	40		5	80		15	144		V DC
R_F	Ohmic resistance		18	20	22	18	20	22	90	95	100	m Ω
L_0	No load inductance	$I_L = 0, T_{C \text{ min}} \dots T_{C \text{ max}}$	30	34	38	30	34	38	88	100	112	μH
T_A	Ambient temperature	$I_F = I_{Fn}$	-40		80	-40		80	-40		95	$^\circ\text{C}$
T_C	Case temperature		-40		92	-40		92	-40		98	
T_S	Storage temperature		-40		100	-40		100	-55		100	

For currents $I_F > 4$ A the following derating takes place: $T_{A \text{ max}} = 100 - 1.3 \cdot I_F^2$ [$^\circ\text{C}$], $T_{C \text{ max}} = 100 - 0.49 \cdot I_F^2$ [$^\circ\text{C}$]

Input Interference Reduction

An AC ripple current can be measured at the input of any switching regulator, even if they are equipped with an input filter. Depending on the types of filters used, common and/or differential mode interferences can be reduced. They will also help to further increase the surge and burst immunity of the power supplies.

The FP filters considerably increase the source impedance of the regulators superimposed interference, to a value which is normally high in comparison to the impedance of the source (Z_{Line}). The interference currents are therefore practically independent of their source impedance. The filter will reduce these currents by approximately 25 dB at a frequency of 150 kHz.

The interference voltages at the filter input are due to the remaining interference currents flowing through the source impedance. The resulting interference voltage reduction can be seen in the following figure. For frequencies above the regulator switching frequency the attenuation will increase (up to 2 MHz approx.).

Parallel operation: When several switching regulator inputs are connected in parallel, each regulator should be equipped with a separate input filter. Interconnections should only be made in front of the filter or at its input U_{ii} (i. e. the central ground point should be before or at the filter and under no circumstances at the regulator input).

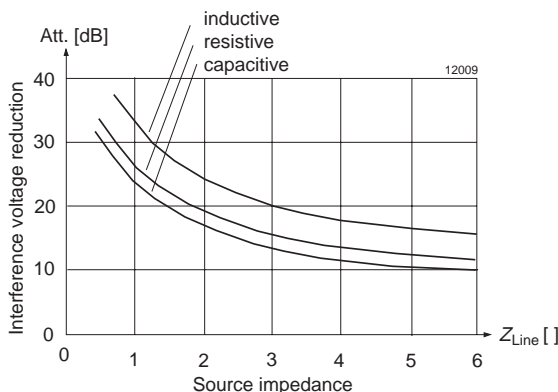

Reduction of Output Ripple

Even though switching regulators have an inherently low output ripple, certain sensitive applications need even further reduction. In such cases, the filters designed to reduce disturbances at the input, can also be used for reducing the ripple on the output voltage (even better results with regard to the ripple and dynamic control deviation can be achieved by using low-loss ring core chokes in combination with an external capacitor, see below).

The output ripple can be reduced by the use of filter blocks by about 24 dB. The formula for the ripple u_R at the load R_L is as follows:

$$u_R = 0.063 \cdot u_o$$

(Ripple voltage u_o is given for specific regulators in the corresponding data section).

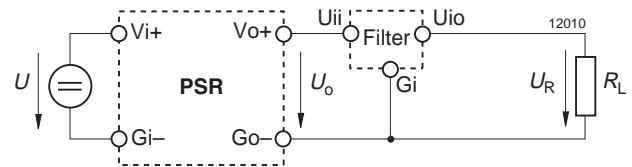

Fig. 2
Reduction of voltage interference by FP filters

Consider, that the filter not only affects the output ripple but can also influence the voltage across the load R_L in the event of load changes. The static load regulation increases with the ohmic resistance of the choke i.e. 24 mV/A for the FP 38 and FP 80 filters and 95 mV/A for the FP 144 filter.

Fig. 1
Interference voltage reduction with FP filters at $f = 150$ kHz

Typical Application

The example in figure *Reduction of voltage interference by FP filters* shows a switching regulator operating from a battery ($R_i < 0.5 \Omega$) with long supply lines (e.g. 2 m). The resulting superimposed interference voltage U_{SL} may be measured at the regulators input. The connection of a filter in front of the power supply will reduce this interference accordingly:

1. The regulator's source impedance is mainly inductive because of the low battery impedance and the long supply lines. It can be calculated as follows:

$$|Z_{Line}| \cong 2 \pi \cdot f_s \cdot L_{Line} \cdot 2 l$$

$$|Z_{Line}| \cong 2 \pi \cdot (150 \cdot 10^3) \cdot 10^{-6} \cdot 2 \cdot 2 \cong 3.8 \Omega$$

f_s : Switching frequency (150 kHz)
 L_{Line} : Supply line inductance (typically 1µH/m)
 l : Length of single supply line (twice for positive and negative path)

2. This example shows, that with an inductive source impedance of 3.8 Ω, the insertion of the filter results in an interference voltage reduction of approx. 18 dB (see fig.: *Interference voltage reduction with FP filters at f = 150 kHz*).
3. The original superimposed interference voltage will be reduced by a factor of approx. 8:

$$U_{SF} = U_{SL} \cdot 10^{-18/20} [V]$$

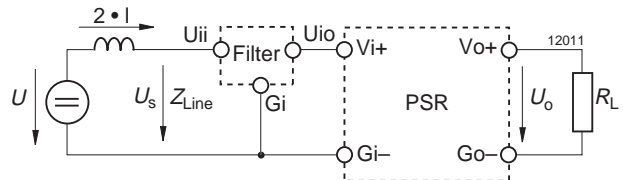

Fig. 3
Reduction of voltage interference by FP filters

Low-Loss Ring Core Chokes L/LP-Series

The ring core chokes, in combination with a capacitor, may easily be used for application specific LC filters at the input or output of switched mode power supplies. All chokes are suitable for PCB mounting. They are either moulded into plastic cases or isolated from the PCB by means of an isolation pad.

Series L/LP20-7 and LP34-3 are intended for use as differential mode filters and the current compensated choke LP183 enables attenuation of common mode interference.

Fig. 4
Choke inductance versus current

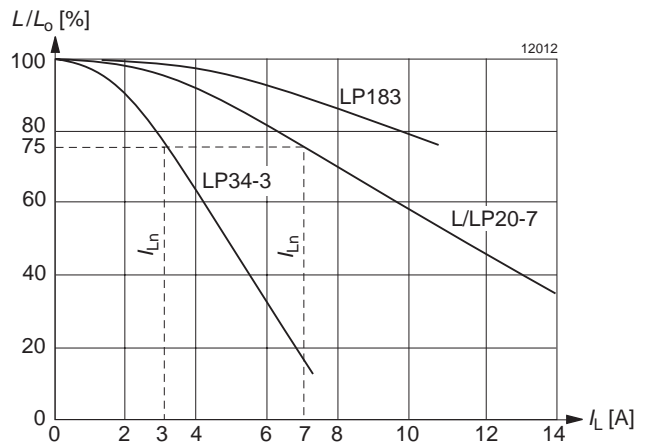

Electrical Data Ring Core Chokes

General Condition: $T_A = 25^\circ C$ unless otherwise specified

Table 3: Ring core chokes

Characteristics		Conditions	L20-7/LP 20-7			LP34-3			LP183			Unit
			min	typ	max	min	typ	max	min	typ	max	
I_{Ln}	Rated current ¹	$L = 0.75 L_o$	7			3			8			A DC
R_L	Ohmic resistance		5	5.5	6	18	20	22	2x2.9	2x4.2	2x5.5	mý
L_o	No load inductance	$I_L = 0, T_C \text{ min...} T_C \text{ max}$	18	20	22	30	34	38	2x95	2x183	2x245	µH
ΔT_I	Current specific case temp. increase ¹		0.082			0.68			0.19			K/A ²
T_A	Amb. temperature ¹	$I_L = I_{Ln}$	-40	106		-40	104		-40	98		°C
T_C	Case temperature		-40	110		-40	110		-40	110		
T_S	Storage temperature		-40	110		-40	110		-40	110		

¹If the choke is not operating at the rated current I_{Ln} , the maximum ambient temperature $T_{A \text{ max}}$ and the maximum direct current $I_{L \text{ max}}$ change according to the following equations:

$$I_{L \text{ max}} = \sqrt{\frac{T_{C \text{ max}} - T_{A \text{ max}}}{\Delta T_I}} \quad T_{A \text{ max}} = T_{C \text{ max}} - I_{L \text{ max}}^2 \cdot \Delta T_I$$

Input Interference Reduction

Using L- or LP-series chokes together with an additional external capacitor a similar attenuation can be achieved as with filter blocks. The capacitor between the choke and the converter input is necessary in order to avoid possible oscillations caused by the negative input impedance of the regulator. This phenomenon could cause the input voltage to leave the specified regulator input range. The relatively high ripple current flowing through the capacitor must be considered for the design. Refer also to: *Technical Information: Installation & Application*.

The current compensated choke LP183 has a high permeability ring core with two identical separate windings. The normal operating current will only see the small stray inductance between the windings. However common mode interference will be blocked by the full inductance of the choke.

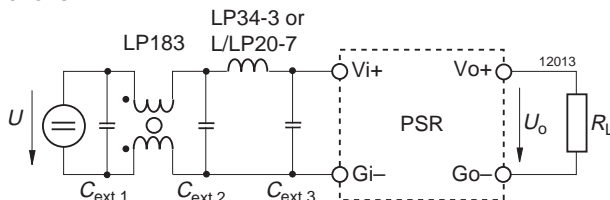

Fig. 5
L/LP type chokes and capacitors used as input filter

Typical Application

A voltage drop $U_{rGo} = r_{Go} \cdot (I_o - I_i)$ is produced across the ground loop resistance r_{Go} . It is superimposed upon the regulator's output voltage U_o and generates the voltage $U_R = U_o - U_{rGo}$ across the load resistance R_L . Without an input inductance L_e the current I_i in the input circuit has a relatively high AC component with a basic frequency f_s (regulator's switching frequency of approx. 150 kHz). This alternating current produces an AC voltage component across r_{Go} which is superimposed upon U_{RL} .

To prevent this phenomenon, an inductance L_e can be inserted into the input circuit. This causes the AC component of the input current to be supplied entirely from the input capacitor C_e ; thus, I_i is a pure direct current. C_e should be wired as close as possible to the regulator's input terminals $Vi+$ and $Gi-$.

L_e and C_e additionally provide protection against input transients and reduce radio interference voltages.

External connection of $Gi-$ and $Go-$ or connection via a common ground is not recommended. The internal voltage drop U_{rG} in the regulator would be superimposed on the output voltage.

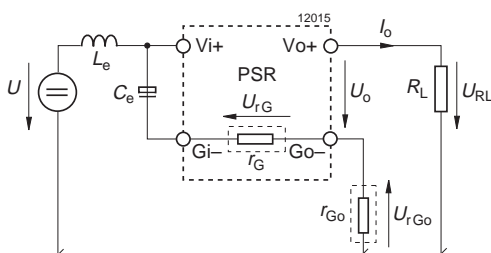

Reduction of Output Ripple

Even though switching regulators have an inherently low output ripple, certain sensitive applications need even further reduction. In such cases, the low-loss ring core chokes designed to reduce disturbances at the input can also be used for reducing the ripple on the output voltage. The chokes in combination with an external capacitor can achieve even better results than the Filter Blocks with regard to the ripple and dynamic regulation.

The formula for the remaining output ripple at the load R_L is calculated as follows:

$$U_R = u_o \cdot Z_{C_{ext}} / Z_{LD}$$

u_o : Output ripple of the regulator

$Z_{C_{ext}}$: The impedance of the capacitor at the regulator's switching frequency (150 kHz) corresponds to the equivalent series resistance (ESR) of the capacitor (please refer to the corresponding data sheet).

$$Z_{LD} = 2 \pi \cdot f_s \cdot L_D$$

f_s : 150 kHz (regulator switching frequency)

Through the use of a common mode choke LP 183, the common mode noise at the output can also be further reduced.

Consider that the filter not only affects the output ripple but can also influence the voltage U_R across the load R_L in the event of load changes. The static regulation increases with the ohmic resistance of the choke, i.e. 6 mV/A for the choke L/LP20-7 and 20 mV/A for the LP34-3.

The dynamic regulation is dependent on the size of the capacitor. Generally, the bigger C_{ex} the smaller is the dynamic, however, recovery will be slower.

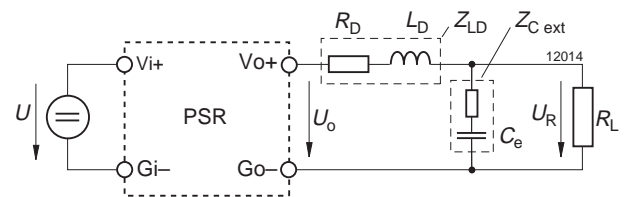

Fig. 7
Low-loss ring core choke with external capacitor (C_{ex} approx. 1000 μ F) used as output filter

Fig. 6
Reduction of superimposed interference voltages in grounded power supply systems, caused by ground loops



Mechanical Dimensions

Dimensions in mm. Tolerances ±0.2 mm unless otherwise specified

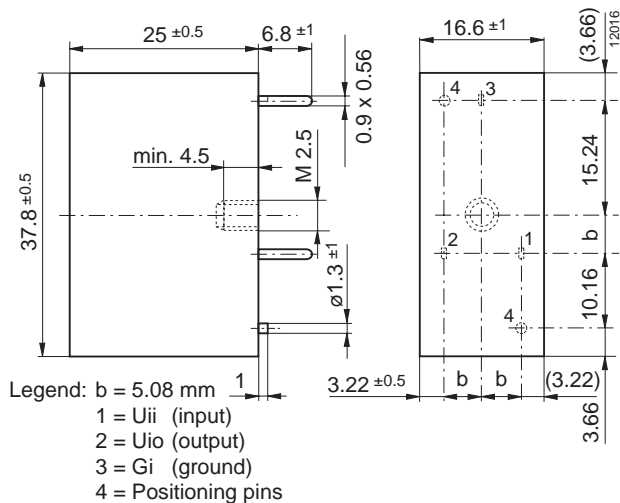

Fig. 8
Filter blocks FP weight 30 g

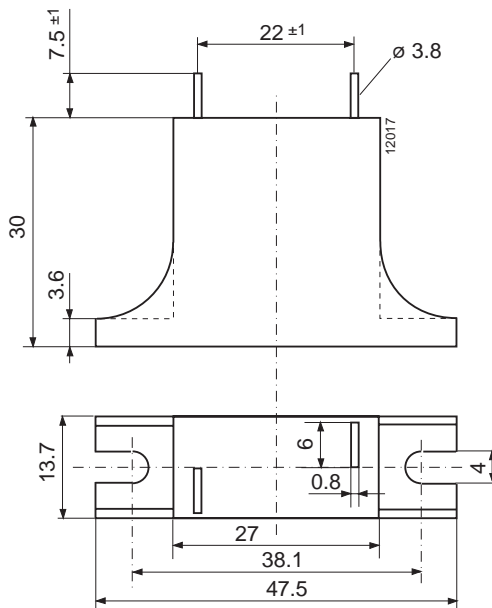

Fig. 9
Differential mode choke L20-7, weight 30 g

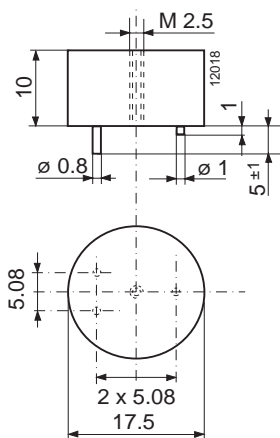

Fig. 10
Differential mode choke LP34-3, weight 7 g

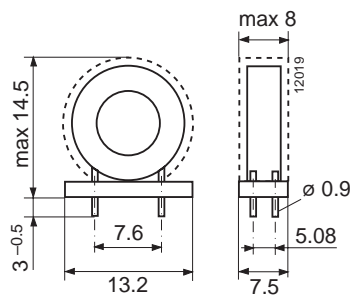

Fig. 11
Common mode choke LP183, weight 7 g

NUCLEAR AND MEDICAL APPLICATIONS - Power-One products are not authorized for use as critical components in life support systems, equipment used in hazardous environments, or nuclear control systems without the express written consent of the respective divisional president of Power-One, Inc.

TECHNICAL REVISIONS - The appearance of products, including safety agency certifications pictured on labels, may change depending on the date manufactured. Specifications are subject to change without notice.