



Embedded Systems

# VMIVME-2536

## 32-Channel Optically Coupled Digital I/O Board with Built-in-Test

- **32 optically coupled outputs**
- **32 optically coupled inputs**
- **High isolation potential**
  - 1 kV sustained
  - 3.5 kV pulsed
- **8-, 16-, 32-bit data transfers**
- **Standard data or short I/O addressing A16 or A24**
- **Voltage sensing or contact sensing inputs**
- **Input ranges of 5 to 125 VDC**
- **300 mA current sinking outputs**
- **50 V maximum output voltage**
- **Supports Built-in-Test for both inputs and outputs**

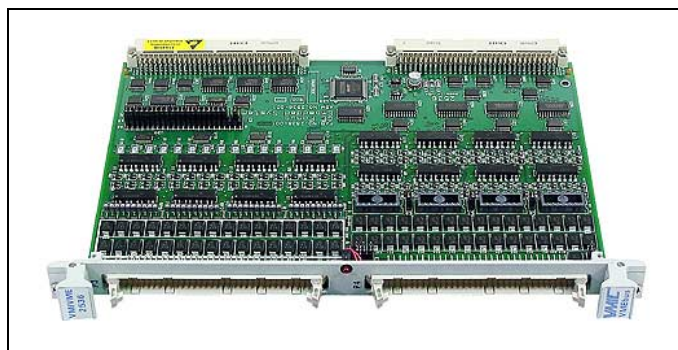

### Functional Characteristics

**Board Function:** This board has 32 optically coupled inputs and 32 optically coupled outputs. Both the outputs and inputs have Built-in-Test capability and provide a sustained 1 kV of system isolation to the VMEbus backplane.

**Compliance:** This board complies with the VMEbus specification ANSI/IEEE STD 1014-1987 IEC 821 and 297 with the following mnemonics:

A24/A16, D32/D16/D08(E0)

Slave with the following Address Modifiers:

3D,39/2D,29.

**Built-in-Test:** The VMIVME-2536 supports both online and offline Built-in-Test (BIT).

Inputs are put into the test mode by setting a bit in the Control and Status Register (CSR). While in the test mode, data placed in onboard test registers are read through the input ports instead of field data. The test registers are at the same address as the input data ports, allowing testing to be achieved by simply writing to and reading from the input data ports. This feature is used for both online and offline testing.

The contents of the Output Data Registers may be read at anytime, thereby supporting online testing. The outputs may be put into offline test mode by setting a bit in the CSR. In the offline test mode, the open-collector outputs are all disabled. Data patterns may then be written to and read from the Output Registers for test purposes without affecting the outputs.

On powerup or reset, the board is placed in the test mode. Output Data Registers should be initialized prior to being put online to avoid undetermined states.

### Ordering Options

August 27, 2004 800-002536-000 E							A	B	C	D	E	F
<b>VMIVME-2536</b>							—	0	0	0	0	0
<b>A = Input Voltage Range</b>												
0 = 5 V												
1 = 12 V												
2 = 24 to 28 V												
3 = 48 V												
4 = 125 V (Voltage Sensing Only)												
<b>B through F = 0 (Options reserved for future use)</b>												
<b>Connector Data</b>												
Compatible Cable Connector						Panduit No. 120-964-435						
Strain Relief						Panduit No. 100-000-072						
PC Board Header Connector						Panduit No. 120-964-033A						
<b>Note</b>												
Panduit is also known as ITW/Pancon.												
<b>For Ordering Information, Call:</b>												
1-800-322-3616 or 1-256-880-0444 • FAX (256) 882-0859												
Email: <a href="mailto:info.embeddedsystems@gefanuc.com">info.embeddedsystems@gefanuc.com</a>												
Web Address: <a href="http://www.gefanuc.com/embedded">www.gefanuc.com/embedded</a>												
Copyright © 2004 by VMIC												
Specifications subject to change without notice.												

**Addressing Scheme:** The board is organized in 8-bit ports. Four input ports and four output ports, stacked one longword boundary above Board ID and CS Registers. A total of 16 bytes of address space is occupied.

**Address Map:**

Relative Address	Register Name
\$00	BD ID (Board ID)
\$02	Control and Status (CSR)
\$04	Input Data Register 0
\$05	Input Data Register 1
\$06	Input Data Register 2
\$07	Input Data Register 3
\$08	Output Data Register 0
\$09	Output Data Register 1
\$0A	Output Data Register 2
\$0B	Output Data Register 3
\$0C	Reserved
\$0D	Reserved
\$0E	Reserved
\$0F	Reserved

### Input Characteristics

**Input Configuration:** The inputs can be voltage sensing or contact sensing. Voltage sensing or contact sensing may be set on byte boundaries. For contact sensing, a user-supplied SIP resistor must be installed. External voltage or internal VMEbus +5 V may be jumper-selected on byte boundaries to supply power for contact sensing mode. Note the VMEbus +5 V is useful only with the 5 V input option.

**Input Voltage Options:** The input voltage range is a manufacturing option. The available ranges are 5, 12, 24, 28, 48, and 125 V. See Tables 1 through 5 for more detailed information and please refer to the Ordering Options.

**Input Isolation:** 10 MΩ, minimum

**Isolation Voltage(1):** 1,000 V sustained;  
3,500 V for one second field to VMEbus.  
500 V sustained channel-to-channel maximum.

**Contact Debounce:** User-programmable debounce is available. Debounce times are 0, .256, .512, 1.024, 2.048, 4.096, 8.192, and 16.384 ms. Debounce defaults to 0 on reset.

### Output Characteristics

**Output Configuration:** The outputs are optically isolated with open collector. The user may install a pull-up resistor on byte boundaries. External voltage or internal VMEbus +5 V may be jumper-selected on byte boundaries to supply power for pull-up resistors.

**Output Leakage Current:**  
500 μA maximum at  $V_{CE} = 50\text{ V}$  and  $T_A = 60\text{ }^\circ\text{C}$

**Output Voltage:** 50 V maximum

**Switching Time:** See Table 6

**Output Isolation:** 10 MΩ, minimum

**Isolation Voltage<sup>1</sup>:** 1,000 V sustained  
3,500 V for one second field to VMEbus.  
500 V sustained channel-to-channel maximum.

### Physical/Environmental Specifications

**Dimensions:** 6U single slot Eurocard form factor

Height	9.2 in. (233.4 mm)
Depth	6.3 in. (160 mm)
Thickness	0.8 in. (20.3 mm)

**User Connectors:** Two 64-pin DIN connectors (one for the inputs and one for the outputs).

**Ambient Temperature:** 0 to 60 °C, operating  
-55 to +85 °C, storage

**Humidity:** 20% to 80%, noncondensing

**Power Requirements:** +5 VDC at 2.65 A

**MTBF:** 463,909 hours\*

\* MTBF calculated using industry standard algorithm,  $1 / (\Sigma \text{FIT} * 1.0 \times 10^9)$ . Wherever possible using component FIT values directly from the respective manufacturers own reliability test programs, not from estimates or known reliability databases.

### Trademarks

All registered trademarks are the property of their respective owners.

1. User-supplied resistors may limit isolation.

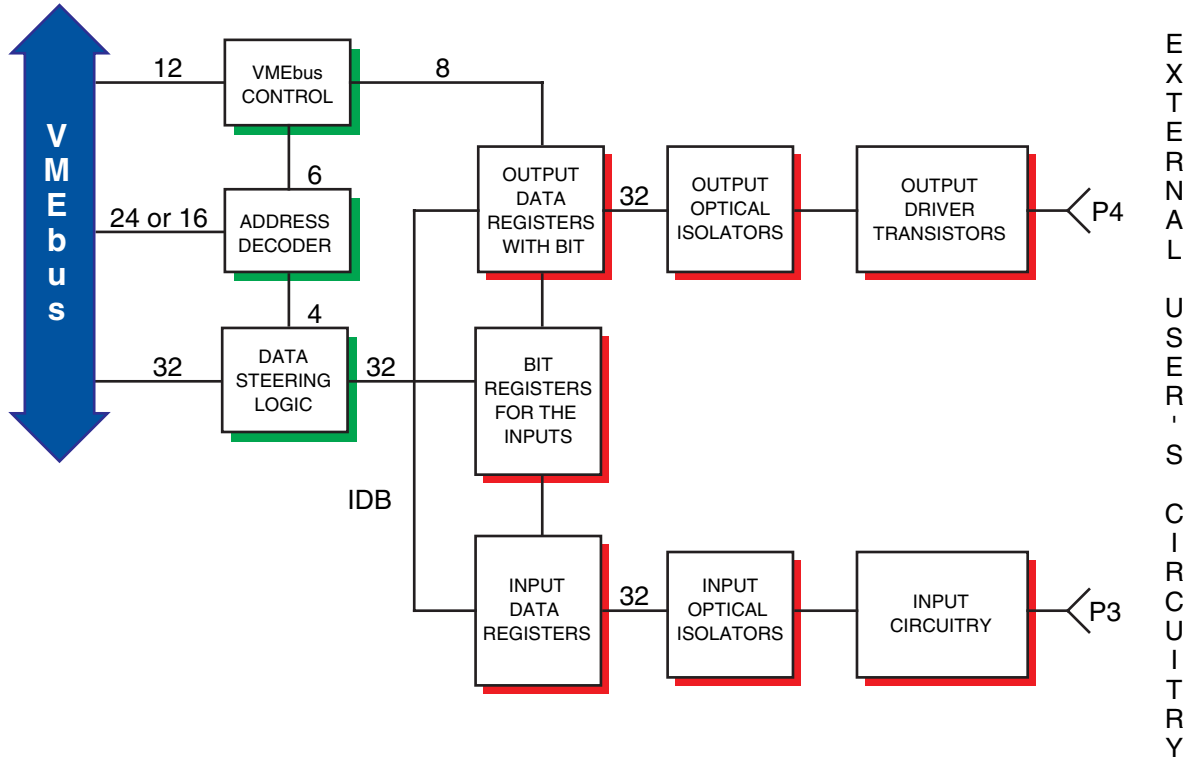

Figure 1. VMIVME-2536 Functional Block Diagram

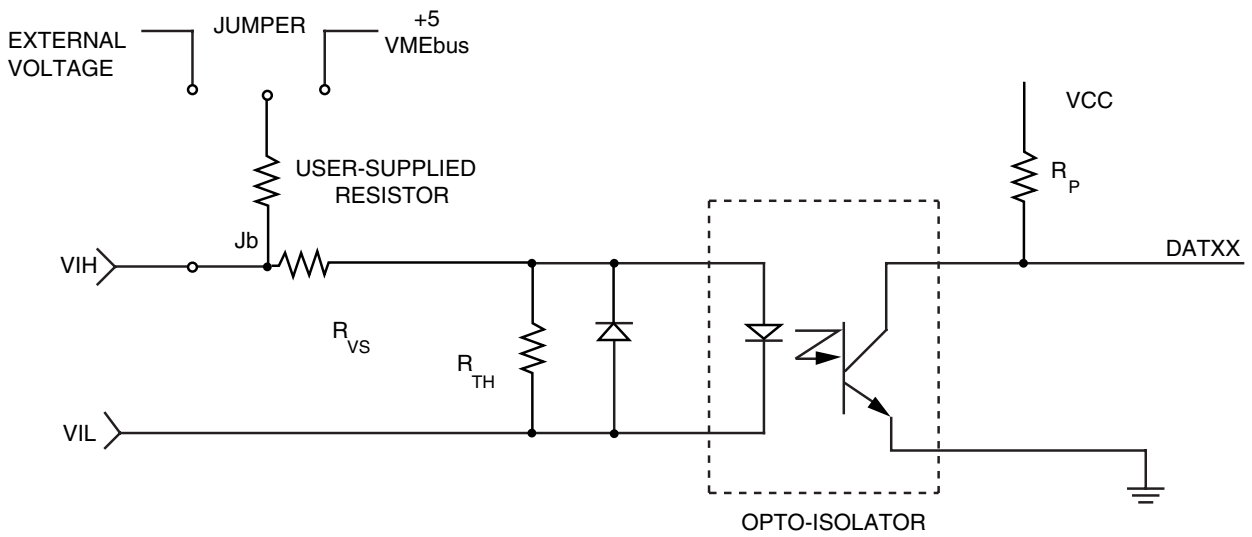
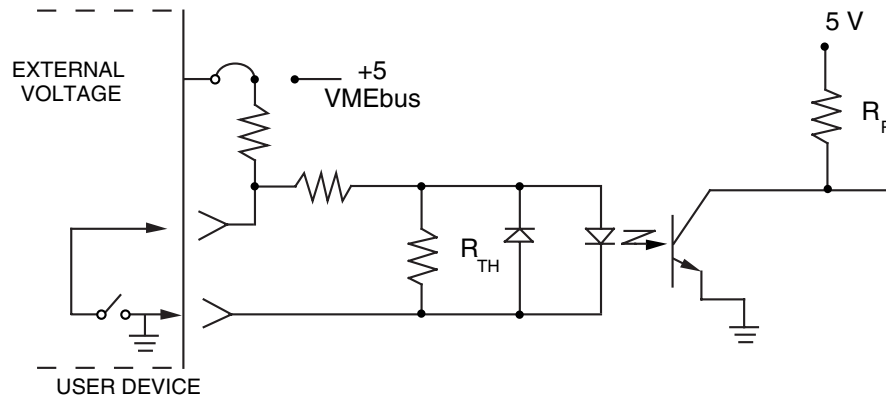
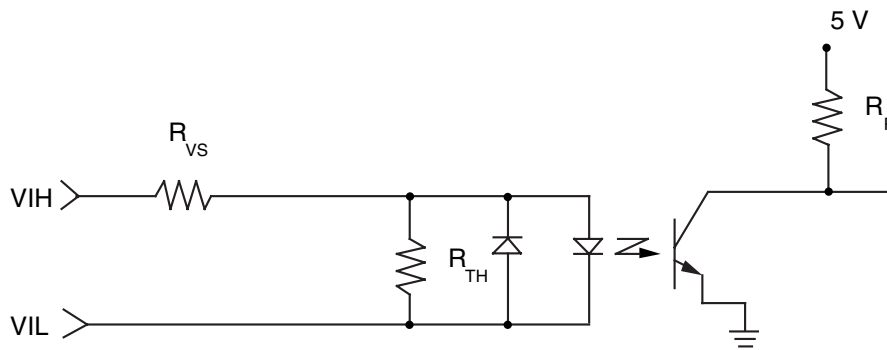

Figure 2. User Input Connection Circuit



a. TYPICAL CONTACT SENSE (CURRENT SINKING) OPTO INPUT

\* CANNOT SUPPORT CONTACT SENSE ON 125 V OPTION.



b. TYPICAL VOLTAGE SENSE OPTO INPUT

Figure 3. Typical VMIVME-2536 OPTO Input Configurations (5 to 125 V Inputs)

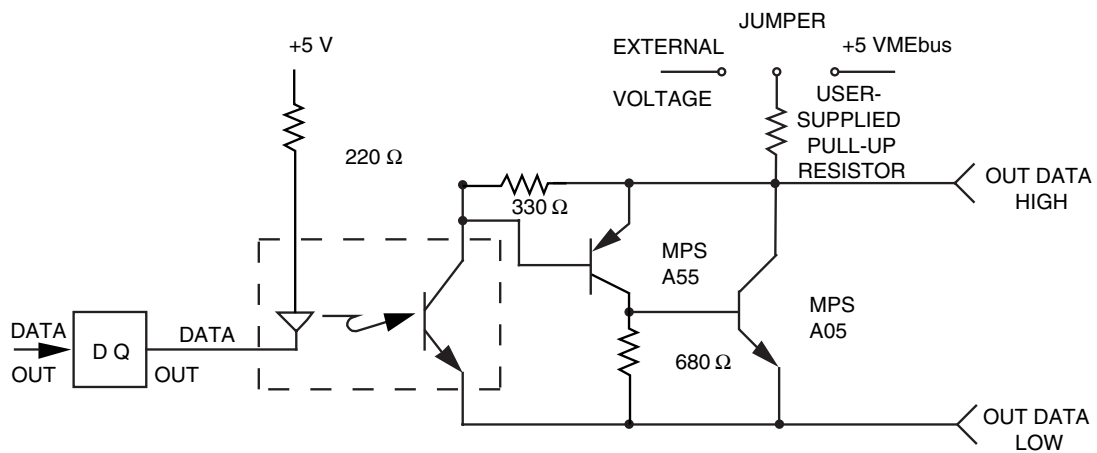

Figure 4. Typical Output Configuration

**Table 1. 5 V Input Option**

PARAMETER	CONDITION	MIN	TYP	MAX	UNITS
$V_{INH}$ – High Threshold Voltage		3.6	2.6		V
$V_{INL}$ – Low Threshold Voltage			2.6	1.8	V
$I_{INH}$ – High Threshold Current	$V_{IN} = 5$ VDC			3.5	mA
$I_{INL}$ – Low Threshold Current	$V_{IN} = V$ $INL^{(MIN)}$			0.7	mA

**Table 2. 12 V Input Option**

PARAMETER	CONDITION	MIN	TYP	MAX	UNITS
$V_{INH}$ – High Threshold Voltage		9.2	5.9		V
$V_{INL}$ – Low Threshold Voltage			5.9	3.4	V
$I_{INH}$ – High Threshold Current	$V_{IN} = 12$ VDC			2.8	mA
$I_{INL}$ – Low Threshold Current	$V_{IN} = V$ $INL^{(MIN)}$			0.7	mA

**Table 3. 24 to 28 V Input Option**

PARAMETER	CONDITION	MIN	TYP	MAX	UNITS
$V_{INH}$ – High Threshold Voltage		21.3	12.9		V
$V_{INL}$ – Low Threshold Voltage			12.9	6.9	V
$I_{INH}$ – High Threshold Current	$V_{IN} = 24$ VDC			2.8	mA
$I_{INL}$ – Low Threshold Current	$V_{IN} = V$ $INL^{(MIN)}$			0.7	mA

**Table 4. 48 V Input Option**

PARAMETER	CONDITION	MIN	TYP	MAX	UNITS
$V_{INH}$ – High Threshold Voltage		43.2	27.0		V
$V_{INL}$ – Low Threshold Voltage			27.0	13.9	V
$I_{INH}$ – High Threshold Current	$V_{IN} = 48$ VDC			2.2	mA
$I_{INL}$ – Low Threshold Current	$V_{IN} = V$ $INL^{(MIN)}$			0.7	mA

**Table 5. 125 V Input Option**

PARAMETER	CONDITION	MIN	TYP	MAX	UNITS
$V_{INH}$ – High Threshold Voltage		105.1	75.2		V
$V_{INL}$ – Low Threshold Voltage			75.2	48.2	V
$I_{INH}$ – High Threshold Current	$V_{IN} = 125$ VDC			2.2	mA
$I_{INL}$ – Low Threshold Current	$V_{IN} = V_{INL(MIN)}$			0.7	mA

**Table 6. Output Characteristics**

PARAMETER	CONDITION	MIN	TYP	MAX	UNITS
$V_{CE}$				50	V
$V_{CE(SAT)}$	$I_{CE} = 300$ mA			1.2	V
$I_{CE}$				300	mA
$I_{CEO}$	$V_{CE} = 50$ V $T_A = 60$ °C			500	μA
$T_D$ ON			7.0		μs
$T_D$ OFF				35	μs

**GE Fanuc Embedded Systems Information Centers**
*USA and the Americas:*

Huntsville, AL 1 800 322-3616  
 1 (256) 880-0444  
 Ventura, CA 1 (805) 650-2111  
 Greenville, SC 1 (864) 627-8800

*Europe, Middle East and Africa:*

Edinburgh, UK 44 (131) 561-3520  
 Paris, France 33 (1) 4324 6007

**Additional Resources**

For more information, please visit the  
 GE Fanuc Embedded Systems web site at:  
[www.gefanuc.com/embedded](http://www.gefanuc.com/embedded)