

# EM1N - Embedded System Module with MPC5200B

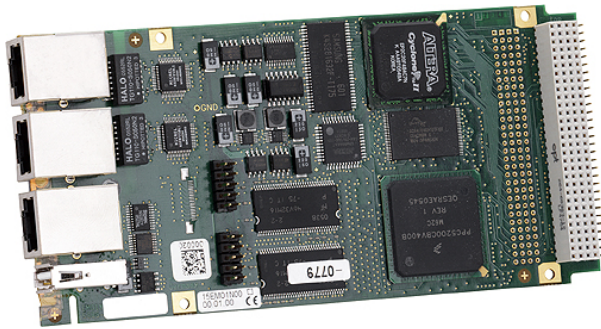

- **MPC5200B / 384 MHz**
- **FPGA 18,752 LEs (225,000 gates)**
- **Up to 256 MB onboard DDR SDRAM**
- **Up to 8 MB boot Flash, NAND Flash**
- **2 MB SRAM, 16 MB additional SDRAM**
- **Dual Ethernet, COM, USB 1.1 (front)**
- **Dual CAN controller on carrier**
- **User defined I/O functions (COMs, graphics, IDE etc.) optional via FPGA on carrier**
- **Stackable with PCI-104**
- **MENMON™ BIOS for PowerPC® cards**
- **-40 to +85°C with qualified components**

The EM1N can be supplied as a stand-alone module, with an application-specific carrier card and/or with additionally plugged PCI-104 modules. The EM1N is controlled by the MPC5200B PowerPC® processor which was specially developed for automotive applications and which operates at up to 400 MHz and 700 MIPS. The complete ESM™ module in standard form has an operational temperature of -40 to +85°C. The CPU consumes less than 1 W at 384 MHz. The EM1N is equipped with up to 256 MB soldered SDRAM and up to 1 GB NAND Flash as well as with 16 MB additional SDRAM, up to 8 MB boot Flash and 2 MB battery-backed SRAM.

The EM1N provides two Fast Ethernet interfaces, one serial line and USB 1.1 at its front panel. As an alternative to RJ45, D-Sub connectors guarantee reliable functions also in harsh environments. Two CAN controllers with V2.0A/B CAN protocol are included in the MPC5200B. The physical CAN interfaces are accessible via SA-Adapters™. Further UARTs and other additional I/O functions can be realized in the on-board FPGA and accessed via a carrier board. The functionality of the FPGA is dynamically loaded by the application software.

The EM1N comes with MENMON™ support. This

firmware/BIOS can be used for bootstrapping operating systems (from disk, Flash or network), for hardware testing, or for debugging applications without running any operating system. The EM1N is designed to operate under harsh environmental conditions including -40 to +85°C operation temperature, shock, vibration, humidity. It focuses on applications in transportation (railways), automotive and avionics.

For a first evaluation of the functions of the EM1N it is strongly recommended to use the EK6N ESM™ starter kit. The kit consists of the standard CPU module, an FPGA loaded with additional I/O functions, the carrier card with I/O connectors, an external PSU, VGA and RJ45 to D-Sub cables, and an adapter for mounting a PCI-104 module.

ESM™ modules are complete computers which consist of the hardware (CPU, chip set, memory, I/O) which is not fixed to any application-specific function, and an FPGA programmed in VHDL code for user-defined I/O. ESM™ modules are based on PCI. They have two system connectors: J1 has a fixed signal assignment, while J2 is variable depending on the final application-specific configuration of the ESM™ and the carrier board. J2 also feeds the I/O signals of the functions programmed in the FPGA to the carrier card.

## Technical Data

### CPU

- PowerPC®
  - MPC5200B
  - Up to 400MHz

### Memory

- 2x16KB L1 data and instruction cache integrated in MPC5200
- Up to 256MB SDRAM system memory
  - Soldered
  - DDR
  - 64MHz memory bus frequency
- Up to 1GB soldered NAND Flash (and more), FPGA-controlled
- 16MB additional SDRAM, FPGA-controlled, e.g. for video data and NAND Flash firmware
- Up to 8MB boot Flash
- 2MB battery-backed SRAM, or: 128KB non-volatile FRAM
- Serial EEPROM 8kbits for factory settings

### Mass Storage

- Parallel IDE (PATA)
  - One port for hard-disk drives
  - Available via I/O connector
  - FPGA-controlled
- Up to 1GB soldered ATA NAND Flash (and more), FPGA-controlled

### Graphics

- Available via I/O connector
- FPGA-controlled

### I/O

- USB
  - One USB 1.1 port
  - Series A connector at front panel
  - OHCI implementation
  - Data rates up to 12Mbits/s
- Ethernet
  - Two 10/100Base-T Ethernet channels
  - One channel FPGA-controlled
  - Two RJ45 or one D-Sub connector at front panel
- One RS232 UART (COM1)
  - RJ45 or D-Sub connector at front panel
  - Data rates up to 115.2kbits/s
  - 512-byte transmit/receive buffer
  - Handshake lines: CTS, RTS
- CAN bus
  - Two CAN bus channels
  - 2.0 A/B CAN protocol
  - Data rates up to 1 Mbit/s
  - Connection via onboard connectors
  - External transceivers using SA-Adapters™
- Further I/O depending on FPGA configuration

### FPGA

- Standard factory FPGA configuration:
  - Main bus interface
  - 16Z070\_IDEDISK - IDE controller for NAND Flash
  - 16Z043\_SDRAM - Additional SDRAM controller (16MB)
  - 16Z023\_IDENHS - IDE controller (PIO mode 0; non-hot-swap)
  - 16Z044\_DISP - Display controller (800 x 600, 60Hz/70Hz, 6-bit RGB)
  - 16Z031\_SPI - SPI touch panel controller
  - 16Z087\_ETH - Ethernet controller (10/100Base-T)
  - 16Z025\_UART - UART controller (controls COM10..COM13)
  - 16Z034\_GPIO - GPIO controller (7 lines)
- The FPGA offers the possibility to add customized I/O functionality. See FPGA.

### PCI Interface

- 32-bit, 32-MHz PCI interface at PCI-104 connector J1
- Compliant with PCI Specification 2.2
- Support of 4 external masters

### Miscellaneous

- Real-time clock
- Power supervision and watchdog

### Electrical Specifications

- Supply voltage/power consumption:
  - +5V (-2%/+5%), 10mA max., only for USB
  - +3.3V (-2%/+5%), 1A typ.
- MTBF: 232,000h @ 40°C (derived from MIL-HDBK-217F)

### Mechanical Specifications

- Dimensions: conforming to ESM™ specification (PCB: 149mm x 71mm), Type I-S
- Weight: 90g (w/o heat sink)

### Environmental Specifications

- Temperature range (operation):
  - -40..+85°C
  - Airspeed: min. 2 m/s
- Temperature range (storage): -40..+85°C
- Relative humidity (operation): max. 95% non-condensing
- Relative humidity (storage): max. 95% non-condensing
- Altitude: -300m to + 3,000m
- Shock: 15g/11ms
- Bump: 10g/16ms
- Vibration (sinusoidal): 2g/10..150Hz
- Conformal coating on request

## Technical Data

### Safety

- PCB manufactured with a flammability rating of 94V-0 by UL recognized manufacturers

### EMC

- Tested according to EN 55022 (radio disturbance), IEC1000-4-2 (ESD) and IEC1000-4-4 (burst)

### BIOS

- MENMON™

### Software Support

- VxWorks®
- Linux (ELinOS)
- QNX®
- PikeOS (partitionable RTOS) certified platform
- CANopen firmware (Vector Informatik)
- CAN support: MEN Driver Interface System (MDIS™ for Windows®, Linux, VxWorks®, QNX®, OS-9®)
- For more information on supported operating system versions and drivers see Software.

## Diagram

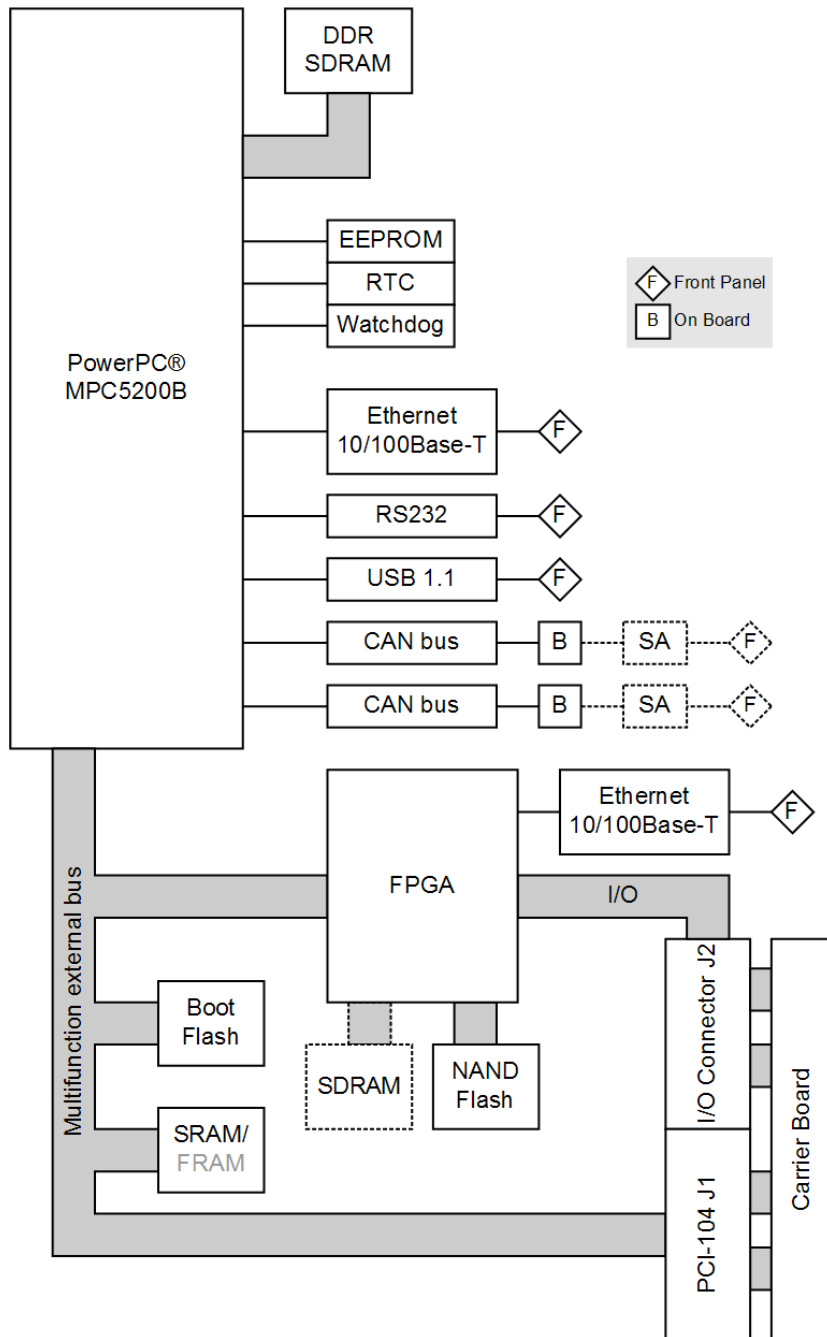

## Configuration & Options

### Standard Configurations

Article No.	CPU Type	FPGA	System RAM	NAND Flash	Boot Flash	Additional SDRAM	SRAM	Misc.
15EM01-00	MPC5200, 384MHz	12,000 LE	128 MB	128 MB	2 MB	16 MB	2 MB	Front I/O
15EM01N00	MPC5200B, 384MHz	18,752 LE	256 MB	1 GB	2 MB	16 MB	2 MB	Front I/O
15EM01A00	MPC5200B, 384MHz	18,752 LE	256 MB	128 MB	2 MB	16 MB	2 MB	Rear I/O
15EM01A01	MPC5200B, 384MHz	18,752 LE	256 MB	128 MB	2 MB	16 MB	2 MB	Rear I/O, 5V only

### Options

#### CPU

- MPC5200B, 384 MHz

#### Memory

- System RAM
  - 128 MB or 256 MB
- NAND Flash
  - 0 MB up to maximum available
- Boot Flash
  - 2 MB, 4 MB or 8 MB
- Additional SDRAM
  - 0 MB or 16 MB
- SRAM
  - 0 MB or 2 MB
- 128KB non-volatile FRAM instead of SRAM

#### I/O

- Front connections
  - D-Sub connectors for Ethernet and COM/USB

#### Mechanical

- PCI and I/O connectors can also be placed for face-to-face assembly (ESM™ Type N)

**Please note that some of these options may only be available for large volumes. Please ask our sales staff for more information.**

## FPGA

### Flexible Configuration

- This MEN board offers the possibility to add customized I/O functionality in FPGA.
- It depends on the board type, pin counts and number of logic elements which IP cores make sense and/or can be implemented. Please contact MEN for information on feasibility.
- [You can find more information on our web page "User I/O in FPGA"](#)

### FPGA Capabilities

- FPGA Altera® Cyclone® II EP2C20
  - 18,752 logic elements
  - 239,616 total RAM bits
- Connection
  - Available pin count: 77 pins
  - Functions available via I/O connector J2
- MEN offers a starter kit for this computer-on-module. The kit includes a suitable carrier board with different I/O connectors for FPGA signals. An FPGA development package for this hardware kit is also available for download.

## Ordering Information

### Standard Hardware

**15EM01N00** MPC5200B/384MHz, FPGA 18,752 logic elements, 256 MB SDRAM, 1 GB NAND Flash, 2 MB SRAM, 16 MB graphics memory, 2 MB boot Flash, front: 2 Fast Ethernet (RJ45), 1 UART (RJ45), 1 USB, -40..+85°C with qualified components (also for ESM evaluation kit EK6N)

### Related Hardware

**08EK06N00** ESM evaluation kit for EM1N: Mini ATX carrier board, EM1N with PowerPC MPC5200B / 384 MHz, 256 MB DDR SDRAM, 1 GB NAND Flash, 2 MB SRAM, 16 MB graphics memory, 2 MB boot Flash, 2 Fast Ethernet, 1 UART, 1 USB 1.1, graphics, IDE, RJ45 to D-Sub cable, VGA cable, external PSU and adapter for mounting of one PCI-104 module, 0..+60°C

**15EM01A00** MPC5200B/384MHz, FPGA 18,752 logic elements, 256MB SDRAM, 128MB NAND Flash, 2MB SRAM, 16MB graphics memory, 2MB boot Flash, -40..+85°C with qualified components

### Miscellaneous

**05F006-00** RS232 interface cable RJ45 to 9-pin D-Sub (1 COM to 1 COM), 2m

### Software: OS independent

**13Z015-06** MDIS5 low-level driver sources (MEN) for 16Z029\_CAN (MSCAN/Layer2)

**13Z016-06** MDIS4/2004 driver (MEN) for 16Z029\_CAN (CANopen master)

**13Z017-06** MDIS5 low-level driver sources (MEN) for 16Z034\_GPIO and 16Z037\_GPIO

### Software: Linux

**10EM01-90** Linux BSP (MEN) for EM1, EM1A, EM1N, EK6, EK6N, F12, F12N and PP1 under ELinOS 5.0 (rpm for direct installation in ELinOS)

**13Z025-90** Linux native driver (MEN) for 16Z025\_UART, 16Z057\_UART and 16Z125\_UART

**13Z077-90** Linux native driver (MEN) for 16Z077\_ETH and 16Z087\_ETH

### Software: VxWorks

**10EM01-60** VxWorks BSP (MEN) for EM1, EM1A, EM1N, EK6, EK6N, F12N and F12

**13Z025-60** VxWorks native driver (MEN) for 16Z025\_UART, 16Z057\_UART and 16Z125\_UART

### Software: QNX

**10EM01-40** QNX BSP (MEN) for EM1, EM1A, EM1N, EK6, EK6N, F12N and F12

**13Z025-40** QNX native driver (MEN) for 16Z025\_UART and 16Z125\_UART

**13Z044-40** QNX native driver (MEN) for 16Z044\_DISP (frame buffer)

**13Z087-40** QNX native driver (MEN) for 16Z087\_ETH

### Software: Firmware/BIOS

**14EM01-00** MENMON (Firmware) for EM1, EM1A, EM1N, F12 and F12N (object code)

### Documentation

**20EM00-00** ESM Specification

**20EM01N00** EM1N/EM1A User Manual

**20EM01NER** EM1N/EM1A Errata

**21APPN009** Application Note: 16Z025\_UART and 16Z125\_UART under Linux

**22Z025-ER** 16Z025\_UART Errata

For the most up-to-date ordering information and direct links to other data sheets and downloads, see the EM1N online data sheet under » [www.men.de](http://www.men.de).

## Contact Information

### Germany

MEN Mikro Elektronik GmbH  
 Neuwieder Straße 5-7  
 90411 Nuremberg  
 Phone +49-911-99 33 5-0  
 Fax +49-911-99 33 5-901  
 E-mail info@men.de  
 www.men.de

### France

MEN Mikro Elektronik SA  
 18, rue René Cassin  
 ZA de la Châtelaine  
 74240 Gaillard  
 Phone +33 (0) 450-955-312  
 Fax +33 (0) 450-955-211  
 E-mail info@men-france.fr  
 www.men-france.fr

### USA

MEN Micro, Inc.  
 24 North Main Street  
 Ambler, PA 19002  
 Phone (215) 542-9575  
 Fax (215) 542-9577  
 E-mail sales@menmicro.com  
 www.menmicro.com

*The date of issue stated in this data sheet refers to the Technical Data only. Changes in ordering information given herein do not affect the date of issue.*

*All brand or product names are trademarks or registered trademarks of their respective holders.*

*Information in this document has been carefully checked and is believed to be accurate as of the date of publication; however, no responsibility is assumed for inaccuracies. MEN Mikro Elektronik accepts no liability for consequential or incidental damages arising from the use of its products and reserves the right to make changes on the products herein without notice to improve reliability, function or design. MEN Mikro Elektronik does not assume any liability arising out of the application or use of the products described in this document.*

*The products of MEN Mikro Elektronik are not suited for use in nuclear reactors or for application in medical appliances used for therapeutical purposes.*

*Application of MEN's products in such plants is only possible after the user has precisely specified the operation environment and after MEN Mikro Elektronik has consequently adapted and released the product.*

*Copyright © 2010 MEN Mikro Elektronik GmbH. All rights reserved.*