

DiskOnChip® IDE Pro

Flash Disk with IDE Interface



Highlights

DiskOnChip IDE Pro is a flash disk with an IDE interface. It combines advanced and proven DiskOnChip technology with a standard IDE interface to complement the DiskOnChip product line.

DiskOnChip IDE Pro provides:

- NAND flash-based technology
- High performance
- Platform independence
- Fast time to market - no driver required
- 40-pin or 44-pin IDE connector
- Hamming code-based EDC/ECC
- 16-bit internal and external operation for 32Mbyte (MB) capacity and higher
- 16-bit external and 8-bit internal operation for 16MB capacity
- IDE Master/Slave modes of operation

IDE Modes

- PIO modes 0-4

Performance

- Host Data Transfer Rate (Max): 16.6MB/sec

Power Requirements

- Single power supply: 5V ($\pm 10\%$)
- Current
 - Active Mode (Max.): 55 mA
 - Sleep/Idle Mode (Max): 0.18 mA



Operating Temperature

- Temperature Range: 0°C to +70°C

Environmental Conditions

- Storage Temperature: -55°C to + 80°C
- Vibration: 1G, each axis
- Shock: 10G, 3 axis

System Compatibility

- Compatible with devices that support the ATA-4 Attachment (without DMA support) for Disk Drives Standard.

Capacity and Packaging

- Available in 16 to 256MB capacity
- Vertical alignment
- 40-pin IDE connector (mm): 56.3 x 30.6 x 6.0 (LxWxH)
- 44-pin IDE connector (mm): 53.0 x 31.2 x 6.0 (LxWxH)

Table of Contents

1. Introduction.....	4
2. Product Overview	5
2.1 Product Description	5
2.2 Pin Assignment.....	6
2.3 Pin Description.....	7
2.4 Capacities and CHS (Cylinder, Head, Sector)	8
3. Theory of Operation	9
3.1 Overview.....	9
4. Description of Command Block Registers.....	10
4.1 Status Register (Read)	10
4.2 Command Register (Write).....	10
4.3 Error Register (Read)	11
4.4 Feature Register (Write).....	11
4.5 Sector Number Register (LBA 0-7) (Read/Write).....	11
4.6 Cylinder Low Register (LBA 8-15) (Read/Write)	12
4.7 Cylinder High Register (LBA 16-23) (Read/Write).....	12
4.8 Device/Head Register (Read/Write)	13
4.9 Sector Count Register (Read/Write).....	13
4.10 Data Register (Read/Write)	13
4.11 Alternate Status Register (Read).....	14
4.12 Device Control Register (Write).....	14
5. Supported ATA Command Set	15
5.1 Command Set Description.....	16
5.1.1 Check Power Mode – 98h, E5h	16
5.1.2 Execute Drive Diagnostics – 90h	16
5.1.3 Identify Drive – ECh	17
5.1.4 Idle – 97h, E3h	19
5.1.5 Idle Immediate – 95h, E1h	19
5.1.6 Initialize Drive Parameters – 91h	20
5.1.7 Read Buffer – E4h.....	20
5.1.8 Read Multiple – C4h.....	21
5.1.9 Read Sector(s) – 20h, 21h.....	22
5.1.10 Read Long Sector – 22H, 23h	23
5.1.11 Read Verify Sector(s) – 40h, 41h.....	24
5.1.12 Recalibrate – 1Xh	25
5.1.13 Seek – 7Xh.....	26
5.1.14 Set Features – EFh.....	26
5.1.15 Set Multiple Mode – C6h.....	27
5.1.16 Set Sleep Mode – 99h, E6h	28
5.1.17 Standby – 96h, E2h	28
5.1.18 Standby Immediate – 94h, E0h.....	29
5.1.19 Write Buffer – E8h.....	29
5.1.20 Write Long Sector – 32h, 33h	30
5.1.21 Write Multiple Command – C5h	31

5.1.22	Write Sector(s) – 30h, 31h	32
5.1.23	Write Verify Sector(s) – 3Ch	33
5.2	Valid Error and Status Register Values	34
6.	Installation Requirements.....	35
6.1	Connecting DiskOnChip IDE Pro Electrically	35
6.2	Installing DiskOnChip IDE Pro in a Two-Drive Configuration (Master/Slave)	36
7.	Power Management.....	37
8.	Specifications	38
8.1	Environmental Specifications	38
8.2	Mechanical Dimensions.....	38
8.3	Physical Characteristics.....	39
8.3.1	Weight	39
8.4	Absolute Maximum Ratings.....	40
8.5	Electrical Specifications	40
8.5.1	DC Characteristics	40
8.5.2	AC Characteristics	41
9.	Ordering Information.....	42

1. Introduction

This data sheet includes the following sections:

- Section 1:** Overview of data sheet contents
- Section 2:** Product overview, including brief product description, pin assignment and description
- Section 3:** Theory of operation
- Section 4:** Descriptions of Command Block registers
- Section 5:** Modes of operation and supported ATA command set
- Section 6:** Installation requirements
- Section 7:** Power Management
- Section 8:** Environmental, mechanical, electrical and production specifications
- Section 9:** Product ordering information

For additional information on M-Systems' flash disk products, please contact one of the offices listed on the back page.

2. Product Overview

2.1 Product Description

DiskOnChip IDE Pro complements the DiskOnChip product line, offering full IDE capabilities, high performance, a built-in ECC system and flexible design options. It can be used in any system with an IDE bus and can work with any operating system, since the driver is handled at the BIOS level. DiskOnChip IDE Pro offers both internal and external 16-bit operation. This provides for superior performance over other IDE alternatives.

DiskOnChip IDE Pro is based on NAND flash technology. This technology is superior in its data storage characteristics, featuring the industry's highest write and erase performance, as well as the highest burst read/write transfer rate. Additionally, NAND flash technology is known for its high density and small die size, with the related cost and real estate benefits. Data integrity is guaranteed through embedded error detection and error correction code (EDC/ECC) that automatically detects and corrects data errors. The EDC/ECC algorithm is based on Hamming code and can detect up to 2 bits and correct 1 bit per 512 bytes.

DiskOnChip IDE Pro is ergonomically designed for easy installation and ready-to-run operation. Available in 40-pin and 44-pin connector packages, DiskOnChip IDE Pro fits easily into any platform with an IDE connector. A LED provides activity indication, while a specially designed case enables easy insertion. A screw hole can be used to secure DiskOnChip IDE Pro firmly in place.

DiskOnChip IDE Pro is available in capacities ranging from 16MB to 256MB, making the upgrade path simple and fast.

2.2 Pin Assignment

See Table 1 for the pin assignment of DiskOnChip IDE Pro.

Table 1: Pin Assignment

Pin No.	Signal	Function	Pin No.	Signal	Function	
1	RESET#	Host reset	2	GND	Ground	
3	HD7	Host Data bit 7	4	HD8	Host Data bit 8	
5	HD6	Host Data bit 6	6	HD9	Host Data bit 9	
7	HD5	Host Data bit 5	8	HD10	Host Data bit 10	
9	HD4	Host Data bit 4	10	HD11	Host Data bit 11	
11	HD3	Host Data bit 3	12	HD12	Host Data bit 12	
13	HD2	Host Data bit 1	14	HD13	Host Data bit 13	
15	HD1	Host Data bit 1	16	HD14	Host Data bit 14	
17	HD0	Host Data bit 0	18	HD15	Host Data bit 15	
19	GND	Ground	20	40-pin	VCC ¹	Supply Voltage
				44-pin	KEY	Cut pin
21	NC	Not Connected	22	GND	Ground	
23	HLOW#	Host I/O Write	24	GND	Ground	
25	HIOR#	Host I/O Read	26	GND	Ground	
27	IORDY	I/O Ready	28	CSEL	Master/Slave Select	
29	NC	Not Connected	30	GND	Ground	
31	INTRQ	Interrupt Request	32	IOIS16#	CS I/O 16-bit	
33	HA1	Host Address bit 1	34	PDIAG#	Passed Diagnostics	
35	HA0	Host Address bit 0	36	HA2	Host Address bit 2	
37	CS0#	Chip Select 0	38	CS1#	Chip Select 1	
39	DASP#	Drive Active/ Drive 1 Present	40	GND	Ground	
41 ²	VCC	Supply Voltage	42 ²	VCC	Supply Voltage	
43 ²	GND	Ground	44 ²	RESERVED	Reserved	

1) In the 40-pin version, this pin is defined as VCC to reduce the need for an external power connector. In the 44-pin version, this pin is defined as KEY, according to the ATA standard.

2) DiskOnChip IDE Pro 40-pin version does not contain pins 41-44.

NC = These pins are not connected internally.

RESERVED = All reserved signals must be left floating.

2.3 Pin Description

Table 2 contains the pin description of DiskOnChip IDE Pro.

Table 2: Pin Description

Signal	Pin No.	Description	Signal Type
RESET#	1	Host reset: Active low.	Input
HD15-HD0	3-18	Host Data bus [15:0]. 16-bit bi-directional data input/output bus. HD15 is the most significant bit, while HD0 is the least significant bit. This bus carries data, commands and status information between the host and DiskOnChip IDE Pro. The lower 8 bits are used for 8-bit register transfers. Data transfers are 16-bits wide.	I/O
DLOW#	23	Device I/O Write: Active low. Gates the data from the bus into DiskOnChip IDE Pro. The clocking occurs on the rising edge of the signal.	Input
DIOR#	25	Device I/O Read: Active low. Gates the data onto the bus from DiskOnChip IDE Pro. The clocking occurs on the falling edge of the signal.	Input
IORDY	27	I/O Ready: Negated by DiskOnChip IDE Pro to extend the host transfer cycle (Read or Write) when the device is not ready to respond to a data transfer request.	Output
CSEL	28	Configuration Select: Determines the device configuration as either Master or Slave. If CSEL is negated, then the device address is Master; if CSEL is asserted, then the device address is Slave.	Input
INTRQ	31	Interrupt Request: Interrupt request from DiskOnChip IDE Pro to the host. The output of this signal is tri-stated if the host disables the interrupt. When asserted, this signal is negated by the device within 400 nsec of the negation of DIOR# that reads the Status register. When asserted, this signal is negated by the device within 400 nsec of the negation of DLOW# that writes the Command register.	Output
IOIS16#	32	I/O IS 16-Bit: Active low. Asserted (low) by DiskOnChip IDE Pro to indicate to the host that the current cycle is a 16-bit (word) data transfer. When the signal is negated (high), an 8-bit data transfer is performed.	Output
HA2-HA0	33,35,36	Host Address bus HA[2:0]: Select the registers in the DiskOnChip IDE Pro controller.	Input
PDIAG#	34	Passed Diagnostics: Active low. Informs the Master drive that the self-diagnostic of the Slave drive has ended.	I/O
CS0#	37	Host Chip Select 0: Active low. Selects the Command Block registers.	Input
CS1#	38	Host Chip Select 1: Active low. Selects the Command Block registers.	Input
DASP#	39	Drive Active/Drive1 Present: Active low. This is a time-multiplexed signal that indicates that a device is active, or that Device 1 is present.	I/O
GND	2,19,22,24,26,30,40,43	Ground	Ground
VCC	41, 42	Power supply	Supply

2.4 Capacities and CHS (Cylinder, Head, Sector)

Table 3 shows the various capacities available for DiskOnChip IDE Pro, as well as the CHS (Cylinder, Head and Sector) for each capacity. If DiskOnChip IDE Pro is not identified or your platform does not support auto-detection, use the following parameters to complete the Drive Parameter Table.

Table 3: Drive Parameters

Unformatted Disk Capacity (MB)	Formatted Disk Capacity (# of Sectors)	Cylinders	Heads	Sectors/Heads	Bytes/Sector
16	31744	496	2	32	512
32	63488	992	2	32	512
64	126976	248	16	32	512
128	253952	496	16	32	512
256	507904	992	16	32	512

3. Theory of Operation

3.1 Overview

Figure 1 shows DiskOnChip IDE Pro operation from the system level, including the major hardware blocks.

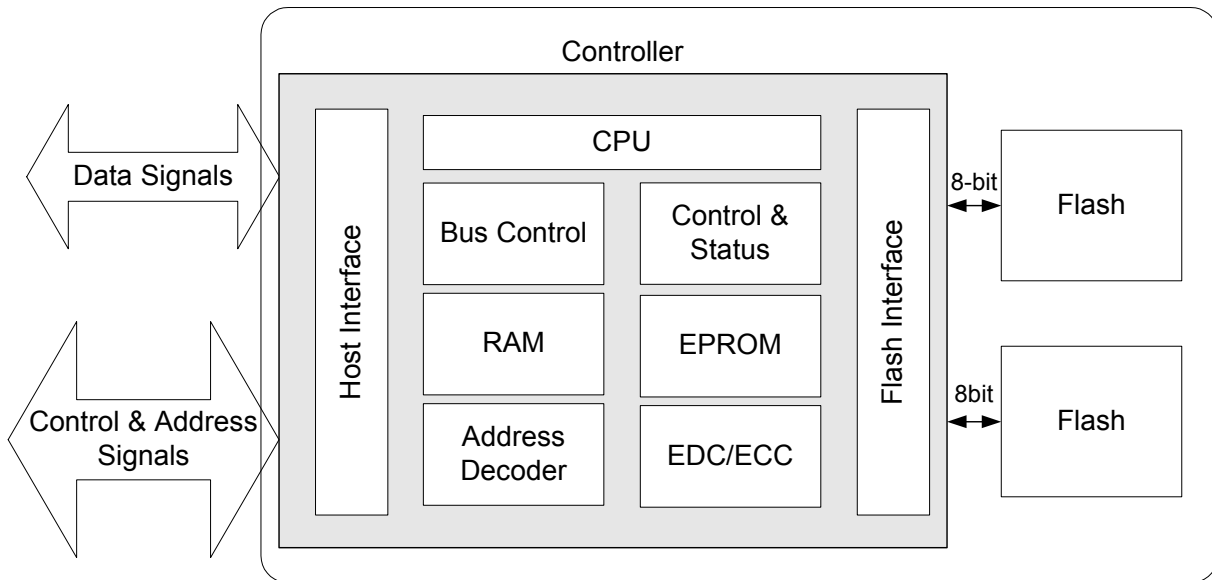

Figure 1: DiskOnChip IDE Pro Block Diagram

DiskOnChip IDE Pro integrates an IDE controller and flash devices. Communication with the host occurs through the host interface, using the standard ATA protocol. Communication with the flash device(s) occurs through the flash interface.

The IDE controller incorporates a Control & Status block that consists of the Command Block registers. The ATA commands that instruct the IDE controller which operation needs to be executed are written/read from the Command Block registers. The data blocks are also transferred via the Command Block Registers. A description of the Command Block registers can be found in Section 4.

The embedded EDC/ECC mechanism is based on the Hamming code algorithm, and can detect up to 2 bits and correct 1 bit per 512 bytes.

4. Description of Command Block Registers

The Command Block registers are used for sending commands to the device or posting status from the device. These registers include the Cylinder High, Cylinder Low, Device/Head, Sector Count, Sector Number, Command, Status, Features, Error, and Data registers. The Control Block registers are used for device control and to post alternate status. These registers include the Device Control and Alternate Status registers.

4.1 Status Register (Read)

This register contains the device status. The contents of this register are updated to reflect the current state of the device and the progress of any command being executed by the device. When BSY=0, the other bits in this register are valid. When BSY=1, other bits in this register are not valid. The contents of this register and all other Command Block Registers are not valid when the device is in Sleep mode.

Bit 7	Bit 6	Bit 5	Bit 4	Bit 3	Bit 2	Bit 1	Bit 0
BSY	DRDY	DF	DSC	DRQ	CORR	IDX	ERR

Bit No.	Description
0	ERR. When set, indicates that an error has occurred during the previous command execution. The bits in the Error register indicate the cause. See Section 5.2 for an overview of error codes.
1	IDX (Index). Index is vendor specific.
2	CORR (Corrected Data). Indicates a correctable data error. The definition of what constitutes a correctable error is vendor specific.
3	DRQ (Data Request). When set, indicates that the device is ready to transfer a word or byte of data between the host and the device.
4	DSC (Drive Seek Complete). When set, indicates that the requested sector was found.
5	DF (Device Fault). Indicates that a device fault error has been detected.
6	DRDY (Device Ready). Indicates whether the device is capable of performing drive operations (commands). This bit is cleared at power up and remains cleared until the drive is ready to accept a command.
7	BSY (Busy). Set whenever the device has control of the Command Block registers. When BSY=1, the commands written to this register will be ignored by the device.

4.2 Command Register (Write)

This register contains the ATA command code that the host sends to the device. Command execution begins immediately after this register is written. This register is write-only when BSY=0 and DRQ=0. The contents of this register and all other Command Block registers are not valid when the device is in Sleep mode.

Bit 7	Bit 6	Bit 5	Bit 4	Bit 3	Bit 2	Bit 1	Bit 0
Command Code							

4.3 Error Register (Read)

The Error register contains additional information about the source of an error. The content of this register is only valid when BSY=0 and DRQ=0 in the Status register and the ERR bit is asserted.

Bit 7	Bit 6	Bit 5	Bit 4	Bit 3	Bit 2	Bit 1	Bit 0
Reserved	UNC	MC	IDNF	MCR	ABRT	TKONF	AMNF

Bit No.	Description
0	AMNF (Address Mark Not Found). Indicates that the data address mark has not been found after finding the correct ID field.
1	TKONF (Track 0 Not Found). Indicates that track 0 has not been found during a RECALIBRATE command.
2	ABRT (Abort). Indicates that the requested command has been aborted because the command code or a command parameter is invalid or some other error has occurred.
3	MCR (Media Change Request). Not supported.
4	IDNF (ID-field Not Found). Requested sector ID-field Not Found.
5	MC (Media Changed). Not supported.
6	UNC (Uncorrected). Non-correctable data error encountered.
7	Reserved.

4.4 Feature Register (Write)

This register is command specific, and is write-only when BSY=0 and DRQ=0.

Bit 7	Bit 6	Bit 5	Bit 4	Bit 3	Bit 2	Bit 1	Bit 0
Command Specific							

4.5 Sector Number Register (LBA 0-7) (Read/Write)

The content of this register depends on the selected mode of address translation: CHS (Cylinder, Head, Sector) or LBA (Logical Block Address) mode. In CHS mode (LBA=0 in Device/Head register), this register contains the subsequent command's starting sector number, which can be from 1 to the maximum number of sectors per track. In LBA mode (LBA=1 in Device/Head register), this register contains LBA bits 0-7, which are updated upon command completion. This register is write-only when BSY=0 and DRQ=0.

Bit 7	Bit 6	Bit 5	Bit 4	Bit 3	Bit 2	Bit 1	Bit 0
CHS Mode							
SN7	SN6	SN5	SN4	SN3	SN2	SN1	SN0
LBA Mode							
LBA7	LBA6	LBA5	LBA5	LBA3	LBA2	LBA1	LBA0

Bit No.	Description
CHS Mode	
0-7	SN[0:7] (Sector Numbers 0-7)
LBA Mode	

0-7	LBA[0:7] (Logical Block Addresses 0-7)
-----	--

4.6 Cylinder Low Register (LBA 8-15) (Read/Write)

The contents of this register depend on the value of LBA bits 8-15 in the Device/Head register. If LBA=0, this register contains the 8 least significant bits of the starting cylinder address (CL bits 0-7). If LBA=1, this register contains LBA bits 8-15. This register is write-only when BSY=0 and DRQ=0.

Bit 7	Bit 6	Bit 5	Bit 4	Bit 3	Bit 2	Bit 1	Bit 0
CHS Mode							
CL7	CL6	CL5	CL4	CL3	CL2	CL1	CL0
LBA Mode							
LBA15	LBA14	LBA13	LBA12	LBA11	LBA10	LBA9	LBA8

Bit No.	Description
CHS Mode	
0-7	CL[0:7] (Cylinder Low Bits 0-7)
LBA Mode	
0-7	LBA[8:15] (Logical Block Addresses 8-15)

4.7 Cylinder High Register (LBA 16-23) (Read/Write)

In CHS mode, the Cylinder High register contains the 8 high bits of the cylinder numbers, and reflects their status at command completion. In LBA mode, this register contains LBA bits 16-23 and reflects their status at command completion. This register is write-only when BSY=0 and DRQ=0.

Bit 7	Bit 6	Bit 5	Bit 4	Bit 3	Bit 2	Bit 1	Bit 0
CHS Mode							
CH7	CH6	CH5	CH4	CH3	Ch2	CH1	CH0
LBA Mode							
LBA23	LBA22	LBA21	LBA20	LBA19	LBA18	LBA17	LBA16

Bit No.	Description
CHS Mode	
0-7	CH[0:7] (Cylinder High Bits 0-7)
LBA Mode	
0-7	LBA[16:23] (Logical Block Addresses 16-23)

4.8 Device/Head Register (Read/Write)

This register selects the device and defines address translation mode as CHS or LBA. In CHS mode it provides the head address. In LBA mode, it provides the assignment for LBA[27:24]. This register is write-only when BSY=0 and DRQ=0.

Bit 7	Bit 6	Bit 5	Bit 4	Bit 3	Bit 2	Bit 1	Bit 0
CHS Mode							
1	LBA	1	DEV	HS3	HS2	HS1	HS0
LBA Mode							
Reserved				LBA27	LBA26	LBA25	LBA24

Bit No.	Description
CHS Mode	
0-3	HS[0:3] (Head Starting Address Bits 0-3). When LBA=0 (CHS), these bits contain the head address of the starting CHS address. Bit HS3 is the most significant bit.
4	DEV (Device Address). 0 = Master drive selected. 1 = Slave drive selected.
6	LBA (Address Mode Select). 0 = CHS (Cylinder, Head, Sector) mode. 1 = LBA (Logical Block Address) mode.
LBA Mode	
0-3	LBA[24:27] (Logical Block Addresses 24-27). When LBA=1 (LBA mode), these bits represent LBA bits 24-27.
4-7	Reserved.

4.9 Sector Count Register (Read/Write)

The Sector Count register contains the number of data sectors requested to be transferred during a read or write operation between the host and the device. A zero value specifies 256 sectors. The command is successful if this register is zero on command completion. This register is write-only when BSY=0 and DRQ=0.

Bit 7	Bit 6	Bit 5	Bit 4	Bit 3	Bit 2	Bit 1	Bit 0
Sector Count							

4.10 Data Register (Read/Write)

The Data register is a 16-bit register used to transfer data blocks between the device's data buffer and the host. This register can be written or the content is valid on read when DRQ=1.

Bit 7	Bit 6	Bit 5	Bit 4	Bit 3	Bit 2	Bit 1	Bit 0
D7	D6	D5	D4	D3	D2	D1	D0
Bit 15	Bit 14	Bit 13	Bit 12	Bit 11	Bit 10	Bit 9	Bit 8
D15	D14	D13	D12	D11	D10	D9	D8

4.11 Alternate Status Register (Read)

This register contains the device status. The contents of this register are updated to reflect the current state of the device and the progress of any command being executed by the device. The contents of this register, except for BSY, is ignored when BSY=1. BSY is valid at all times. The contents of the register and all other Command Block registers are not valid while a device is in Sleep mode.

Bit 7	Bit 6	Bit 5	Bit 4	Bit 3	Bit 2	Bit 1	Bit 0
BSY	DRDY	DF	DSC	DRQ	CORR	IDX	ERR

See Section 4.1 for the bit descriptions.

4.12 Device Control Register (Write)

This register allows a host to software reset attached devices and to enable or disable the assertion of the INTRQ signal by a selected device. This register can only be written when DMACK# is not asserted.

Bit 7	Bit 6	Bit 5	Bit 4	Bit 3	Bit 2	Bit 1	Bit 0
Reserved					SRST	#IEN	Reserved

Bit No.	Description
0	Reserved. Clear this bit to 0.
1	#IEN (Interrupt Enable). 0 = Enables interrupts to the host (using the #IREQ tri-state pin). 1 = Disables all pending interrupts (#IREQ in high-Z).
2	SRST (Soft Reset). This is the host software reset bit.
3-7	Reserved.

5. Supported ATA Command Set

This section defines the format of the commands the host sends to DiskOnChip IDE Pro. The commands are issued to the device by loading the required registers in the command block with the supplied parameters, and then writing the command code to the register.

DiskOnChip IDE Pro supports the IDE commands listed in Table 4.

Table 4: Supported IDE Commands

Command Code	Command Name	Register				
		FR	SC	SN	CY	D/H
98h E5h	CHECK POWER MODE	-	-	-	-	D
90h	EXECUTIVE DEVICE DIAGNOSTIC	-	-	-	-	D
ECh	IDENTIFY DEVICE	-	-	-	-	D
97h E3h	IDLE	-	✓	-	-	D
95h E1h	IDLE IMMEDIATE	-	-	-	-	D
91h	INITIALIZE DEVICE PARAMETERS	-	✓	-	-	D+H
E4h	READ BUFFER	-	-	-	-	D
C4h	READ MULTIPLE	-	✓	✓	✓	D+H
20h 21h	READ SECTOR(S)	-	✓	✓	✓	D+H
22h 23h	READ LONG SECTOR(S)	-	-	✓	✓	D+H
40h 41h	READ VERIFY SECTOR(S)	-	✓	✓	✓	D+H
10h	RECALIBRATE	-	-	-	-	D
70h	SEEK	-	-	✓	✓	D+H
EFh	SET FEATURES	✓	-	-	-	D
C6h	SET MULTIPLE MODE	-	✓	-	-	D
99h E6h	SET SLEEP MODE	-	-	-	-	D
96h E2h	STANDBY	-	-	-	-	D
94h E0h	STANDBY IMMEDIATE	-	-	-	-	D
E8h	WRITE BUFFER	-	-	-	-	D
3Ch	WRITE VERIFY	-	✓	✓	✓	✓
C5h	WRITE MULTIPLE	-	✓	✓	✓	D+H
30h 31h	WRITE SECTOR(S)	-	✓	✓	✓	D+H
32h 33h	WRITE LONG SECTOR(S)	-	✓	✓	✓	D+H
00h	NOP	-	-	-	-	D

Definition of Abbreviations:

Registers – FR: Feature register, SC: Sector Count register, SN: Sector Number register, CY: Cylinder registers, DH: Drive/Head register

Symbols – ✓: The register is valid, D: Only drive parameters are valid, H: Only head parameters are valid

5.1 Command Set Description

5.1.1 Check Power Mode – 98h, E5h

This command checks the current power mode of DiskOnChip IDE Pro.

When this command is issued in Sleep mode, or is being set to/recovering from Sleep mode, DiskOnChip IDE Pro sets the BSY bit in the Status register and the Sector Count register to 00h. Then the BSY bit is cleared, and an interrupt is generated.

When DiskOnChip IDE Pro is in Idle mode, it sets the BSY bit in the Status register and the Sector Count register to FFh. Then the BSY bit in the Status register is cleared, and an interrupt is generated.

INPUT								
Register	7	6	5	4	3	2	1	0
Features								
Sector Count								
Sector Number								
Cylinder Low								
Cylinder High								
Device/Head	1		1	D				
Command	98h or E5h							

OUTPUT								
Register	7	6	5	4	3	2	1	0
Status	BSY	DRDY	DF	DSC	DRQ	CORR	IDX	ERR
	0	1	0	1	0	0	0	0
Sector Count	Power Mode Code (00h or FFh)							
Error	R	UNC	MC	IDNF	MCR	ABRT	TKONF	AMNF
		0	0	0	0	0	0	0

5.1.2 Execute Drive Diagnostics – 90h

This command performs self-diagnostics on various internal components of DiskOnChip IDE Pro. Results of the diagnostics are reported in the Error register. Note that the bit definitions for the Error register do not apply to this command. Instead, the value in the Error register is a diagnostic code.

INPUT								
Register	7	6	5	4	3	2	1	0
Features								
Sector Count								
Sector Number								
Cylinder Low								
Cylinder High								
Device/Head				D				
Command	90h							

OUTPUT								
Register	7	6	5	4	3	2	1	0
Status	BSY	DRDY	DF	DSC	DRQ	CORR	IDX	ERR
	0	✓	0	✓	✓	✓	0	✓
Error	Diagnostic code (see below)							

Code	Description
01H	No error detected
02H	Formatter device error
03H	Sector buffer error
04H	ECC logic error
05H	Slave failed

5.1.3 Identify Drive – ECh

The Identify Drive command enables the host to receive parameter information from DiskOnChip IDE Pro. When the command is issued, the device performs the following sequence: sets the BSY bit, prepares to transfer the 256 words of device identification data to the host, sets the DRQ bit, clears the BSY bit, and generates an interrupt. The host can then transfer the data by reading the Data register. All reserved bits or words are set to 0. See Table 5 to identify drive information for this device.

INPUT								
Register	7	6	5	4	3	2	1	0
Features								
Sector Count								
Sector Number								
Cylinder Low								
Cylinder High								
Device/Head				D				
Command	ECh							

OUTPUT								
Register	7	6	5	4	3	2	1	0
Status	BSY	DRDY	DF	DSC	DRQ	CORR	IDX	ERR
	0	✓	0	1	✓	✓	0	0
Error	R	UNC	MC	IDNF	MCR	ABRT	TKONF	AMNF
		0	0	0	0	✓	0	0

Table 5: Identify Drive Descriptions

Word	Data	Description
0	040AH	General configuration bit-significant information
1	XXXX	Number of cylinders
2	0000H	Reserved
3	XXXX	Number of heads
4	0000H	Number of unformatted bytes per track
5	0200H	Number of unformatted bytes per sector
6	XXXX	Number of sectors per track
7-8	XXXX	Number of sectors per device (Word7= MSW, Word 8= LSW)
9	0000H	Reserved
10-19	XXXX	Serial Number in ASCII
20	0002H	Buffer type: dual ported, multi-sector, with read cache
21	0002H	Buffer size in 512 byte increments
22	0004H	# of ECC bytes passed on Read/Write Long Commands
23-26	XXXX	Firmware revision in ASCII
27-46	XXXX	Model number in ASCII
47	0001H	Maximum of 1 sector on Read/Write Multiple command
48	0000H	Cannot perform double word I/O (32 bits)
49	0200H	Capabilities: DMA not Supported (bit 8), LBA supported (bit 9)
50	0000H	Reserved
51	0200H	PIO data transfer cycle timing mode 2
52	0000H	DMA data transfer cycle timing mode not supported
53	0001H	Word 54-58 are valid
54	XXXX	Current numbers of cylinders
55	XXXX	Current numbers of heads
56	XXXX	Current sectors per track
57-58	XXXX	Current capacity in sectors (LBA)(Word 57= LSW, Word 58= MSW)
59	010XH	Multiple sector setting is valid
60-61	XXXX	Total number of sectors addressable in LBA Mode
62-127	0000H	Reserved
128-159	0000H	Reserved vendor unique bytes
160-255	0000H	Reserved

5.1.4 Idle – 97h, E3h

This command causes DiskOnChip IDE Pro to set BSY, enter Idle mode, clear BSY and generate an interrupt. If the sector count is not 0, it is intercepted as a timer count (with a time base of 5 milliseconds, which differs from the ATA specification) and automatic Power-Down mode is enabled. If the sector count is 0, automatic Power-Down mode is disabled.

INPUT								
Register	7	6	5	4	3	2	1	0
Features								
Sector Count	Timer Count (5 msec increments)							
Sector Number								
Cylinder Low								
Cylinder High								
Device/Head				D				
Command	E3h or 97h							

OUTPUT								
Register	7	6	5	4	3	2	1	0
Status	BSY	DRDY	DF	DSC	DRQ	CORR	IDX	ERR
	0	✓	0	1	0	0	0	✓
Error	R	UNC	MC	IDNF	MCR	ABRT	TKONF	AMNF
		0	0	0	0	✓	0	0

5.1.5 Idle Immediate – 95h, E1h

This command causes DiskOnChip IDE Pro to set BSY, enter Idle mode, clear BSY and generate an interrupt.

INPUT								
Register	7	6	5	4	3	2	1	0
Features								
Sector Count								
Sector Number								
Cylinder Low								
Cylinder High								
Device/Head				D				
Command	E1h or 95h							

OUTPUT								
Register	7	6	5	4	3	2	1	0
Status	BSY	DRDY	DF	DSC	DRQ	CORR	IDX	ERR
	0	✓	0	1	0	0	0	✓

Error	R	UNC	MC	IDNF	MCR	ABRT	TKONF	AMNF
		0	0	0	0	✓	0	0

5.1.6 Initialize Drive Parameters – 91h

Initialize Drive Parameters allows the host to alter the number of sectors per track and the number of heads per cylinder. This command does not check the validity of counts of sectors and heads. If an invalid value is set, an error is reported when another command attempts an invalid access. The Sector Count register specifies the number of logical sectors per logical track, and the Device/Head register specifies the maximum head number.

INPUT								
Register	7	6	5	4	3	2	1	0
Features								
Sector Count	Number of sectors per track.							
Sector Number								
Cylinder Low								
Cylinder High								
Device/Head	X	0	X	D	Head counts per cylinder			
Command	91h							

OUTPUT								
Register	7	6	5	4	3	2	1	0
Status	BSY	DRDY	DF	DSC	DRQ	CORR	IDX	ERR
	0	✓	0	1	✓	✓	0	✓
Error	R	UNC	MC	IDNF	MCR	ABRT	TKONF	AMNF
		0	0	0	0	✓	0	0

5.1.7 Read Buffer – E4h

This command enables the host to read the current contents of the device's sector buffer. When this command is issued, the device sets the BSY bit, enables the sector buffer for a read operation, sets the DRQ bit, clears the BSY bit, and generates an interrupt. The host then reads the data from the buffer.

INPUT								
Register	7	6	5	4	3	2	1	0
Features								
Sector Count								
Sector Number								
Cylinder Low								
Cylinder High								
Device/Head				D				
Command	E4h							

OUTPUT								
Register	7	6	5	4	3	2	1	0

Status	BSY	DRDY	DF	DSC	DRQ	CORR	IDX	ERR
	0	✓	0	1	1	0	0	✓
Error	R	UNC	MC	IDNF	MCR	ABRT	TKONF	AMNF
		0	0	0	0	✓	0	0

5.1.8 Read Multiple – C4h

This command functions like the Read Sector(s) command, but instead of issuing interrupts for each sector, it issues interrupts when a block is transferred that contains the counts of sectors defined by the Set Multiple command. The DRQ required for the transfer should be set only at the start of the data block and does not affect other sectors. When the Read Multiple command is issued, the requested sectors (not the block counts or the sector counts in a block) are written into the Sector Count register. Errors occurring during command execution are reported at the start of a complete or partial block transfer. The transfer continues even if DRQ is set and the data is corrupted. After the data transfer, the task file content (with the block data containing the sectors where the error occurred) is undefined. To obtain valid error information the host must request a re-transmission. The next block or part of a block is transferred only if the error is correctable. For all other errors, the command is aborted after transferring a block containing an error.

INPUT								
Register	7	6	5	4	3	2	1	0
Features								
Sector Count	The number of sectors/logical blocks to transfer							
Sector Number	Sector[7:0] or LBA[7:0] of the sector/LBA to transfer							
Cylinder Low	Cylinder[7:0] or LBA[15:8] of the sector/LBA to transfer							
Cylinder High	Cylinder[15:8] or LBA[23:16] of the sector/LBA to transfer							
Device/Head	1	LBA	1	D	Head (LBA 27-24)			
Command	C4h							

OUTPUT								
Register	7	6	5	4	3	2	1	0
Status	BSY	DRDY	DF	DSC	DRQ	CORR	IDX	ERR
	0	✓	0	1	✓	✓	0	✓
Sector Count								
Sector Number								
Cylinder Low								
Cylinder High								
Device/Head								
Error	R	UNC	MC	IDNF	MCR	ABRT	TKONF	AMNF
		✓	0	✓	0	✓	0	0

5.1.9 Read Sector(s) – 20h, 21h

This command allows the host to read up to 256 sectors as specified in the Sector Count register. A sector count of 0 indicates a transfer request of 256 sectors. The transfer starts from the sector specified in the Sector Number register. DRQ is set prior to the transfer, regardless of the error state. The command ends by placing the cylinder, head and sector number of the last read sector in the task file. If an error occurs, the read operation aborts in the sector with the error. The Cylinder, Head and Sector number of the sector with the error is placed in the task file. The error data remains in the data buffer. The Cylinder Low, Cylinder High, Device/Head and Sector Number or LBA registers specify the starting sector address to be read. The Sector Count register specifies the number of sectors to be transferred.

INPUT								
Register	7	6	5	4	3	2	1	0
Features								
Sector Count	The number of sectors/logical blocks to transfer							
Sector Number	Sector[7:0] or LBA[7:0] of the sector/LBA to transfer							
Cylinder Low	Cylinder[7:0] or LBA[15:8] of the sector/LBA to transfer							
Cylinder High	Cylinder[15:8] or LBA[23:16] of the sector/LBA to transfer							
Device/Head	1	LBA	1	D	H[3:0] or LBA[27:24] of the sector/LBA to transfer			
Command	20h (with retry) and 21h (without retry)							

OUTPUT								
Register	7	6	5	4	3	2	1	0
Status	BSY	DRDY	DF	DSC	DRQ	CORR	IDX	ERR
	0	1	0	1	✓	✓	0	✓
Sector Count								
Sector Number								
Cylinder Low								
Cylinder High								
Device/Head								
Error	R	UNC	MC	IDNF	MCR	ABRT	TKONF	AMNF
	0	✓	0	✓	0	✓	0	0

5.1.10 Read Long Sector – 22H, 23h

Read Long Sector (with and without retry) is similar to the Read Sectors command, except that it returns 516 bytes of data instead of 512 bytes. During a Read Long Sector command, DiskOnChip IDE Pro does not check the ECC bytes to determine if there has been a data error. Only single sector read long operations are supported. The transfer consists of 512 bytes of data transferred in word mode, followed by 4 bytes of random data transferred in byte mode. Random data is returned instead of ECC bytes because of the nature of the ECC system used.

INPUT								
Register	7	6	5	4	3	2	1	0
Features								
Sector Count	The number of sectors/logical blocks to transfer. This should be set to 01 for compatibility							
Sector Number	Sector[7:0] or LBA[7:0] of the sector/LBA to transfer							
Cylinder Low	Cylinder[7:0] or LBA[15:8] of the sector/LBA to transfer							
Cylinder High	Cylinder[15:8] or LBA[23:16] of the sector/LBA to transfer							

Device/Head	1	LBA	1	D	H[3:0] or LBA[27:24] of the sector/LBA to transfer			
Command	22h (with retry) and 23h (without retry)							

OUTPUT								
Register	7	6	5	4	3	2	1	0
Status	BSY	DRDY	DF	DSC	DRQ	CORR	IDX	ERR
	0	✓	0	1	✓	✓	0	✓
Sector Count								
Sector Number								
Cylinder Low								
Cylinder High								
Device/Head								
Error	R	UNC	MC	IDNF	MCR	ABRT	TKONF	AMNF
		0	0	✓	0	✓	0	0

5.1.11 Read Verify Sector(s) – 40h, 41h

The Read Verify Sectors command verifies one or more sectors on DiskOnChip IDE Pro by transferring data from the flash media to the data buffer in the controller and verifying that the ECC is correct. This command is performed identically to the Read Sector(s) command, except that DRQ is not asserted, and no data is transferred to the host.

When the command is accepted, DiskOnChip IDE Pro sets BSY. When the requested sectors have been verified, DiskOnChip IDE Pro clears BSY and generates an interrupt. Upon command completion, the Command Block registers contain the cylinder, head, and sector number of the last sector verified. If an error occurs, the command terminates at the sector where the error occurs. The Command Block registers contain the cylinder, head and sector number of the sector where the error occurred. The Sector Count register contains the number of sectors not yet verified.

INPUT								
Register	7	6	5	4	3	2	1	0
Features								
Sector Count	The number of sectors/logical blocks to verify							
Sector Number	Sector[7:0] or LBA[7:0] of the sector/LBA to verify							
Cylinder Low	Cylinder[7:0] or LBA[15:8] of the sector/LBA to verify							
Cylinder High	Cylinder[15:8] or LBA[23:16] of the sector/LBA to verify							
Device/Head	1	LBA	1	D	H[3:0] or LBA[27:24] of the sector/LBA to transfer			
Command	40h (with retry) and 41h (without retry)							

OUTPUT								
Register	7	6	5	4	3	2	1	0
Status	BSY	DRDY	DF	DSC	DRQ	CORR	IDX	ERR
	0	1	0	1	✓	✓	0	✓
Sector Count								
Sector Number								
Cylinder Low								
Cylinder High								
Device/Head								
Error	R	UNC	MC	IDNF	MCR	ABRT	TKONF	AMNF
		✓	0	✓	0	✓	0	0

5.1.12 Recalibrate – 1Xh

When this command is executed in CHS addressing mode, the registers Cylinder High, Cylinder Low, and the head portion of Device/Head are set to 0. The Sector Number register is set to 1. If the command is executed in LBA addressing mode, the registers Cylinder High, Cylinder Low, the head portion of the Device/Head, and the Sector Number register are set to zero.

INPUT								
Register	7	6	5	4	3	2	1	0
Features								
Sector Count								
Sector Number								
Cylinder Low								
Cylinder High								
Device/Head	1		1	D				
Command	1Xh							

OUTPUT								
Register	7	6	5	4	3	2	1	0
Status	BSY	DRDY	DF	DSC	DRQ	CORR	IDX	ERR
	0	1	0	1	0	0	0	✓
Error	R	UNC	MC	IDNF	MCR	ABRT	TKONF	AMNF
		0	0	0	0	✓	0	0

5.1.13 Seek – 7Xh

This command seeks and picks up the head to the track specified in the Command Block registers.

INPUT								
Register	7	6	5	4	3	2	1	0
Features								
Sector Count	Sector count							
Sector Number	Sector[7:0] or LBA[7:0] of the sector/LBA to verify							
Cylinder Low	Cylinder[7:0] or LBA[15:8] of the sector/LBA to verify							
Cylinder High	Cylinder[15:8] or LBA[23:16] of the sector/LBA to verify							
Device/Head	1	LBA	1	D	H[3:0] or LBA[27:24] of the sector/LBA to transfer			
Command	7Xh							

OUTPUT								
Register	7	6	5	4	3	2	1	0
Status	BSY	DRDY	DF	DSC	DRQ	CORR	IDX	ERR
	0	✓	0	1	0	0	0	✓
Error	R	UNC	MC	IDNF	MCR	ABRT	TKONF	AMNF
		0	0	✓	0	✓	0	0

5.1.14 Set Features – EFh

The host uses this command to establish or select certain features, described in Table 6.

INPUT								
Register	7	6	5	4	3	2	1	0
Features	Feature number according to the table below							
Sector Count	Configuration required							
Sector Number								
Cylinder Low								
Cylinder High								
Device/Head				D				
Command	EFh							

OUTPUT								
Register	7	6	5	4	3	2	1	0
Status	BSY	DRDY	DF	DSC	DRQ	CORR	IDX	ERR
	0	✓	0	1	0	0	0	✓
Error	R	UNC	MC	IDNF	MCR	ABRT	TKONF	AMNF
		0	0	0	0	✓	0	0

Table 6: Supported Features

Feature	Description
01H	Enable 8 bit data transfer
81H	Disable 8-bit data transfer.

5.1.15 Set Multiple Mode – C6h

This command enables DiskOnChip IDE Pro to perform multiple Read and Write operations and establishes the block count (counts of sectors making up a block) for these commands. The Sector Count register is loaded with the number of sectors per block.

If the Sector Count register contains a valid value and the block count is supported, this value is loaded for all subsequent Read Multiple and Write Multiple commands and execution of these commands is enabled. If a block count is not supported, an Aborted command error is posted, and Read Multiple and Write Multiple commands are disabled. If the Sector Count register contains 0 when the command is issued, multiple Read and Write commands are disabled. At power on, or after a hardware or (unless disabled by a Set Feature command) software reset, the default mode is Read and Write Multiple disabled.

INPUT								
Register	7	6	5	4	3	2	1	0
Features								
Sector Count	Sector Count per Block							
Sector Number								
Cylinder Low								
Cylinder High								
Device/Head				D				
Command	C6h							

OUTPUT								
Register	7	6	5	4	3	2	1	0
Status	BSY	DRDY	DF	DSC	DRQ	CORR	IDX	ERR
	0	✓	0	1	0	0	0	✓
Error	R	UNC	MC	IDNF	MCR	ABRT	TKONF	AMNF
		0	0	0	0	✓	0	0

5.1.16 Set Sleep Mode – 99h, E6h

This command causes DiskOnChip IDE Pro to set BSY, enter Sleep mode, clear BSY and generate an interrupt. Recovery from Sleep mode is accomplished by issuing another command, soft reset or hard reset.

INPUT								
Register	7	6	5	4	3	2	1	0
Features								
Sector Count								
Sector Number								
Cylinder Low								
Cylinder High								
Device/Head				D				
Command	99h or E6h							

OUTPUT								
Register	7	6	5	4	3	2	1	0
Status	BSY	DRDY	DF	DSC	DRQ	CORR	IDX	ERR
	0	1	0	1	0	0	0	✓
Error	R	UNC	MC	IDNF	MCR	ABRT	TKONF	AMNF
		0	0	0	0	✓	0	0

5.1.17 Standby – 96h, E2h

This command causes the device to set BSY, enter Sleep mode (which corresponds to ATA Standby mode), clear the BSY bit, and assert INTRQ. If the Sector Count register is not 0, the Standby timer is enabled. The value in the Sector Count register determines the time programmed into the Standby timer. If the Sector Count register is 0, the Standby timer is disabled.

INPUT								
Register	7	6	5	4	3	2	1	0
Features								
Sector Count	Time period value							
Sector Number								
Cylinder Low								
Cylinder High								
Device/Head				D				
Command	96h or E2h							

OUTPUT								
Register	7	6	5	4	3	2	1	0
Status	BSY	DRDY	DF	DSC	DRQ	CORR	IDX	ERR
	0	✓	0	1	0	0	0	0
Error	R	UNC	MC	IDNF	MCR	ABRT	TKONF	AMNF

		0	0	0	0	✓	0	0
--	--	---	---	---	---	---	---	---

5.1.18 Standby Immediate – 94h, E0h

This command causes the device to immediately enter Standby mode.

INPUT								
Register	7	6	5	4	3	2	1	0
Features								
Sector Count								
Sector Number								
Cylinder Low								
Cylinder High								
Device/Head				D				
Command	94h or E0h							

OUTPUT								
Register	7	6	5	4	3	2	1	0
Status	BSY	DRDY	DF	DSC	DRQ	CORR	IDX	ERR
	0	✓	0	1	0	0	0	1
Error	R	UNC	MC	IDNF	MCR	ABRT	TKONF	AMNF
		0	0	0	0	✓	0	0

5.1.19 Write Buffer – E8h

The Write Buffer command enables the host to rewrite the contents of the DiskOnChip IDE Pro sector buffer with the desired data string. This data buffer can be accessed and read by the Read Buffer command.

INPUT								
Register	7	6	5	4	3	2	1	0
Features								
Sector Count								
Sector Number								
Cylinder Low								
Cylinder High								
Device/Head				D				
Command	E8h							

OUTPUT								
Register	7	6	5	4	3	2	1	0
Status	BSY	DRDY	DF	DSC	DRQ	CORR	IDX	ERR
	0	1	0	✓	0	0	0	✓
Error	R	UNC	MC	IDNF	MCR	ABRT	TKONF	AMNF

		0	0	0	0	✓	0	0
--	--	---	---	---	---	---	---	---

5.1.20 Write Long Sector – 32h, 33h

This command is similar to the Write Sector(s) command, except that it writes 516 bytes instead of 512 bytes. This command can write only one sector at a time. The transfer consists of 512 bytes of data transferred in word mode, followed by four bytes of ECC transferred in byte mode. The four ECC bytes transferred by the host cannot be used by DiskOnChip IDE Pro. The device discards these four bytes and writes the sector with valid ECC fields.

INPUT								
Register	7	6	5	4	3	2	1	0
Features								
Sector Count	Sector count							
Sector Number	Sector[7:0] or LBA[7:0] of the first sector/LBA to transfer							
Cylinder Low	Cylinder[7:0] or LBA[15:8] of the first sector/LBA to transfer							
Cylinder High	Cylinder[15:8] or LBA[23:16] of the first sector/LBA to transfer							
Device/Head	1	LBA	1	D	H[3:0] or LBA[27:24] of the starting sector/LBA			
Command	32h (with retry) or 33h (without retry)							

OUTPUT								
Register	7	6	5	4	3	2	1	0
Status	BSY	DRDY	DF	DSC	DRQ	CORR	IDX	ERR
	0	✓	✓	1	✓	0	0	✓
Sector Count								
Sector Number								
Cylinder Low								
Cylinder High								
Error	R	UNC	MC	IDNF	MCR	ABRT	TKONF	AMNF
		0	0	✓	0	✓	0	✓

5.1.21 Write Multiple Command – C5h

This command is similar to the Write Sectors command. DiskOnChip IDE Pro sets BSY within 400 nsec of accepting the command. Interrupts are not issued for every sector, but rather on the transfer of a block that contains the number of sectors defined by the Set Multiple command. Command execution is identical to the Write Sectors operation, except that the number of sectors defined by the Set Multiple command is transferred without intervening interrupts.

DRQ qualification of the transfer is required only at the start of the data block, not on each sector. The block count of sectors to be transferred without intervening interrupts is programmed by the Set Multiple Mode command, which must be executed prior to the Write Multiple command.

INPUT								
Register	7	6	5	4	3	2	1	0
Features								
Sector Count	Sector count							
Sector Number	Sector[7:0] or LBA[7:0] of the first sector/LBA to transfer							
Cylinder Low	Cylinder[7:0] or LBA[15:8] of the first sector/LBA to transfer							
Cylinder High	Cylinder[15:8] or LBA[23:16] of the first sector/LBA to transfer							
Device/Head		LBA		D	H[3:0] or LBA[27:24] of the starting sector/LBA			
Command	C5h							

OUTPUT								
Register	7	6	5	4	3	2	1	0
Status	BSY	DRDY	DF	DSC	DRQ	CORR	IDX	ERR
	0	✓	✓	1	✓	✓	0	✓
Sector Count								
Sector Number								
Cylinder Low								
Cylinder High								
Error	R	UNC	MC	IDNF	MCR	ABRT	TKONF	AMNF
		0	0	✓	0	✓	0	0

5.1.22 Write Sector(s) – 30h, 31h

This command writes from 1 to 256 sectors as specified in the Sector Count register. A sector count of 0 requests 256 sectors. The transfer begins at the sector specified in the Sector Number register. When this command is accepted, DiskOnChip IDE Pro sets BSY, then sets DRQ and clears BSY, and then waits for the host to fill the sector buffer with the data to be written. No interrupt is generated to start the first buffer fill operation. No data should be transferred by the host until it clears BSY.

For multiple sectors, after the first sector of data is in the buffer, BSY is set and DRQ is cleared. After the next buffer is ready for data, BSY is cleared, DRQ is set and an interrupt is generated. When the final sector of data is transferred, BSY is set and DRQ is cleared. It remains in this state until the command is completed, at which time BSY is cleared and an interrupt is generated.

If an error occurs during a write of more than one sector, writing terminates at the sector where the error occurs. The Command Block registers contain the cylinder, head and sector number of the sector where the error occurred. The host may then read the command block to determine what error has occurred, and in which sector.

INPUT								
Register	7	6	5	4	3	2	1	0
Features								
Sector Count	Sector count							
Sector Number	Sector[7:0] or LBA[7:0] of the first sector/LBA to transfer							
Cylinder Low	Cylinder[7:0] or LBA[15:8] of the first sector/LBA to transfer							
Cylinder High	Cylinder[15:8] or LBA[23:16] of the first sector/LBA to transfer							
Device/Head		LBA		D	H[3:0] or LBA[27:24] of the starting sector/LBA			
Command	30h (with retry) or 31h (without retry)							

OUTPUT								
Register	7	6	5	4	3	2	1	0
Status	BSY	DRDY	DF	DSC	DRQ	CORR	IDX	ERR
	0	✓	✓	1	✓	✓	0	✓
Sector Count								
Sector Number								
Cylinder Low								
Cylinder High								
Error	R	UNC	MC	IDNF	MCR	ABRT	TKONF	AMNF
		0	0	✓	0	✓	0	0

5.1.23 Write Verify Sector(s) – 3Ch

This command writes from 1 to 256 sectors as specified in the Sector Count register. A sector count of 0 requests 256 sectors. The transfer begins at the sector specified in the Sector Number register. When this command is accepted, DiskOnChip IDE Pro sets BSY, then sets DRQ and clears BSY, then waits for the host to fill the sector buffer with the data to be written. No interrupt is generated to start the first buffer fill operation. No data should be transferred by the host until BSY has been cleared by the host.

For multiple sectors, after the first sector of data is in the buffer, BSY is set and DRQ is cleared. After the next buffer is ready for data, BSY is cleared, DRQ is set and an interrupt is generated. When the final sector of data is transferred, BSY is set and DRQ is cleared. It remains in this state until the command is completed, at which time BSY is cleared and an interrupt is generated.

If an error occurs during a write of more than one sector, writing terminates at the sector where the error occurs. The Command Block registers contain the cylinder, head and sector number of the sector where the error occurred. The host may then read the command block to determine what error has occurred, and in which sector.

INPUT								
Register	7	6	5	4	3	2	1	0
Features								
Sector Count	Sector count							
Sector Number	Sector[7:0] or LBA[7:0] of the first sector/LBA to transfer							
Cylinder Low	Cylinder[7:0] or LBA[15:8] of the first sector/LBA to transfer							
Cylinder High	Cylinder[15:8] or LBA[23:16] of the first sector/LBA to transfer							
Device/Head	1	LBA	1	D	H[3:0] or LBA[27:24] of the starting sector/LBA			
Command	3Ch							

OUTPUT								
Register	7	6	5	4	3	2	1	0
Status	BSY	DRDY	DF	DSC	DRQ	CORR	IDX	ERR
	0	✓	✓	1	✓	✓	0	✓
Sector Count								
Sector Number								
Cylinder Low								
Cylinder High								
Error	R	UNC	MC	IDNF	MCR	ABRT	TKONF	AMNF
		0	0	✓	0	✓	0	0

5.2 Valid Error and Status Register Values

Command	Error Register				Status Register				
	UNC	IDNF	ABRT	AMNF	DRDY	DF	DSC	CORR	ERR
Check Power Mode				✓	✓	✓	✓		✓
Execute Drive Diagnostic					✓		✓		✓
Format Track		✓		✓	✓	✓	✓		✓
Identify Drive				✓	✓	✓	✓		✓
Idle				✓	✓	✓	✓		✓
Idle Immediate				✓	✓	✓	✓		✓
Initialize Drive Parameters					✓		✓		✓
Read Buffer				✓	✓	✓	✓		✓
Read Multiple	✓	✓		✓	✓	✓	✓	✓	✓
Read Long Sector		✓		✓	✓	✓	✓		✓
Read Sector(s)	✓	✓		✓	✓	✓	✓	✓	✓
Read Verify Sectors	✓	✓		✓	✓	✓	✓	✓	✓
Recalibrate				✓	✓	✓	✓		✓
Seek		✓		✓	✓	✓	✓		✓
Set Features				✓	✓	✓	✓		✓
Set Multiple Mode				✓	✓	✓	✓		✓
Set Sleep Mode				✓	✓	✓	✓		✓
Standby				✓	✓	✓	✓		✓
Standby Immediate				✓	✓	✓	✓		✓
Write Buffer				✓	✓	✓	✓		✓
Write Long Sector		✓		✓	✓	✓	✓		✓
Write Multiple		✓		✓	✓	✓	✓		✓
Write Sector(s)		✓		✓	✓	✓	✓		✓
Write Verify Sector(s)		✓		✓	✓	✓	✓		✓
Invalid Command Code				✓	✓	✓	✓		✓

Definition of Abbreviations:

✓ = Valid on this command

AMNF: Address Mark Not Found; ABRT: Aborted command; IDNF: Requested sector ID-field NOT found; UNC: Uncorrectable data error; DRDY: Device Ready; DF: Device Fault; DSC: Drive Seek Complete; CORR: Corrected Data; ERR: Error occurred

6. Installation Requirements

6.1 Connecting DiskOnChip IDE Pro Electrically

To connect the 44-pin DiskOnChip IDE Pro to the host, a standard 44-pin cable is required. The cable should not be longer than 18 inches, and should be aligned as follows:

- Pin 1 of the cable must be aligned with pin 1 (see Figure 2) of the header on the drive.
- Pin 44 of the cable must be aligned with pin 44 of the header on the drive.

To connect the 40-pin DiskOnChip IDE Pro to the host, a standard 40-pin cable is required. The cable should not be longer than 18 inches, and should be aligned as follows:

- Pin 1 of the cable must be aligned with pin 1 (see Figure 2) of the header on the drive.
- Pin 40 of the cable must be aligned with pin 40 of the header on the drive.

The 40-pin DiskOnChip IDE Pro has a separate connector for the power supply, to which a power supply cable can be connected. In addition, pin 20 can also be used for power supply connections. Please refer to the pin description for further details..

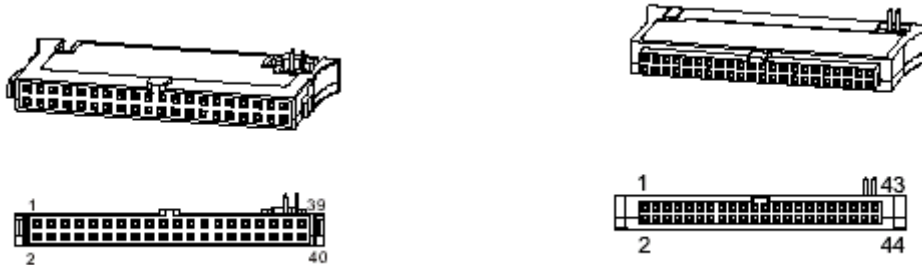

Figure 2: IDE Pro 44-pin (left) and 40-Pin (right) Connector Layouts

6.2 Installing DiskOnChip IDE Pro in a Two-Drive Configuration (Master/Slave)

If DiskOnChip IDE Pro is being installed as an additional IDE drive using the same IDE I/O port, jumper J1 must be set to indicate that this drive is a slave. The default is master with no jumpers. Table 7, Figure 3 and Figure 4 show the J1 jumper settings for DiskOnChip IDE Pro operation in Master and Slave mode.

Table 7: Jumper Settings for Master/Slave Mode

J1 Jumper Settings	Operation Mode
Open	Master
Short pins A to B or C to D	Slave



Figure 3: Slave Settings, 44-pin (left) and 40-pin (right) Connectors



Figure 4: Master Settings, 44-pin (left) and 40-pin (right) Connectors

7. Power Management

DiskOnChip IDE Pro provides automatic power saving mode. There are three operation modes:

1. **Active:** If the DiskOnChip IDE Pro controller receives any Command In or Soft Reset, it enters Active mode. In Active mode, DiskOnChip IDE Pro can execute any supported ATA command. The power consumption level is the highest in this mode.
2. **Idle:** After the DiskOnChip IDE Pro controller executes any ATA command or Soft Reset, it enters Idle mode. Power consumption is reduced as compared with Active mode.
3. **Sleep:** The DiskOnChip IDE Pro controller transfers from Idle into Sleep mode if there is no Command In or Soft Reset from the host for about 16ms. This time interval can be modified by firmware if necessary. In Sleep mode, the power consumption of DiskOnChip IDE Pro is at its lowest level. During Sleep mode, the system main clock is stopped. This mode can be released through a hardware reset, software reset or when any ATA command is asserted.

8. Specifications

8.1 CE and FCC Compatibility

The DiskOnChip IDE Pro conforms to CE requirements and FCC standards.

8.2 Environmental Specifications

8.2.1 Temperature Ranges

Temperature Range 0°C to +70°C

Storage Temperature: -55°C to +80°C

8.2.2 Humidity

Relative Humidity: 10-95%, non-condensing

8.2.3 Shock & Vibration

Reliability Tests	Test conditions	Reference Standard
Vibration	10 Hz to 500 Hz, 1G, 23 min each axis	IEC 68-2-6
Mechanical Shock	Duration: 11ms, 10G, 3 axis	IEC 68-2-27
Drop Unit	1 meter	IEC 68-2-32

8.3 Mechanical Dimensions

See Figure 5 and Figure 6.

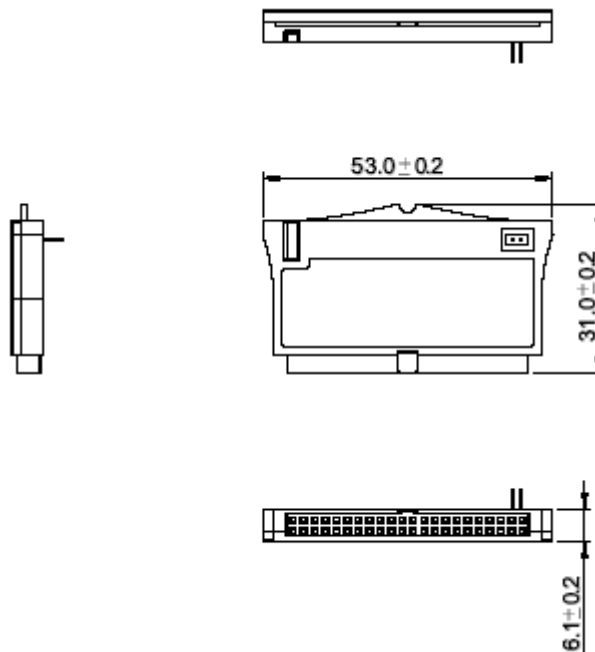

Note: Dimensions are in mm.

Figure 5: Dimensions of 44-Pin DiskOnChip IDE Pro

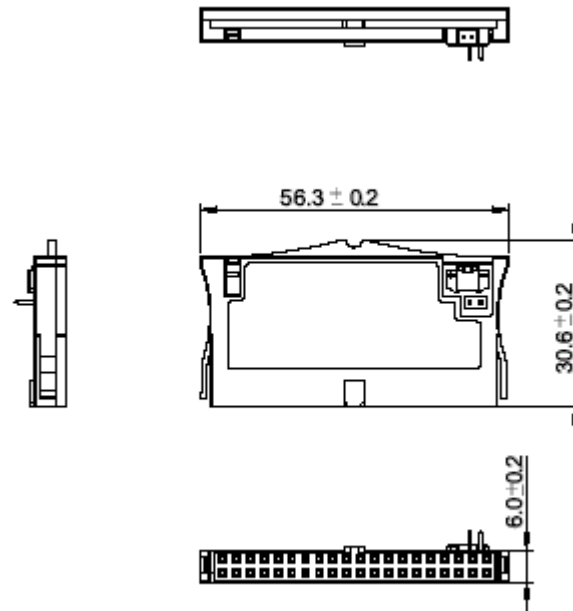

Note: Dimensions are in mm.

Figure 6: Dimensions of 40-Pin DiskOnChip IDE Pro

8.4 Physical Characteristics

8.4.1 Weight

The weight of DiskOnChip IDE Pro depends on the connector type, as shown in Table 8.

Table 8: DiskOnChip IDE Pro Weight

Connector Type	Weight (g)
40-pin	11.0 ± 0.5
44-pin	9.3 ± 0.5

8.5 Absolute Maximum Ratings

Symbol	Parameter	Min	Max	Unit
$V_{DD}-V_{SS}$	DC Power Supply	-0.3	+5.5	V
V_{IN}	Input Voltage	$V_{SS}-0.3$	$V_{DD}+0.3$	V
T_a	Operating Temperature	0	+70	°C
T_{st}	Storage Temperature	-55	+80	°C

8.6 Electrical Specifications

8.6.1 DC Characteristics

Symbol	Parameter	Min	Typ	Max	Unit
V_{IH}	Input voltage (CMOS level)	$0.5 \times V_{CC}$	-	$V_{CC}+0.3$	V
V_{IL}	Input voltage (CMOS level)	-0.3	-	$0.2 \times V_{CC}$	V
V_{IH}	Input voltage (Schmitt trigger)	$0.7 \times V_{CC}$	-	$V_{CC}+0.3$	V
V_{IL}	Input voltage (Schmitt trigger)	-0.3	-	$0.3 \times V_{CC}$	V
I_{source}	Source current	-	11.2	-	mA
I_{sink}	Sink current	-	8.7	-	mA
I_{LI}	Input leakage current	-	-	0.1	μA
I_{LO}	Output leakage current	-	-	0.1	μA
I_{OP}	Operating current (*)	-	35	55	mA
I_{PD}	Power-down current (*)	-	-	0.18	mA
R_{RESET}	Reset resistance	-	100	-	KΩ

Note: $T_a=0^{\circ}\text{C}$ to $+70^{\circ}\text{C}$, $V_{CC}=5.0\text{V} \pm 10$

*Measured with flash memory and host interface

8.6.2 AC Characteristics

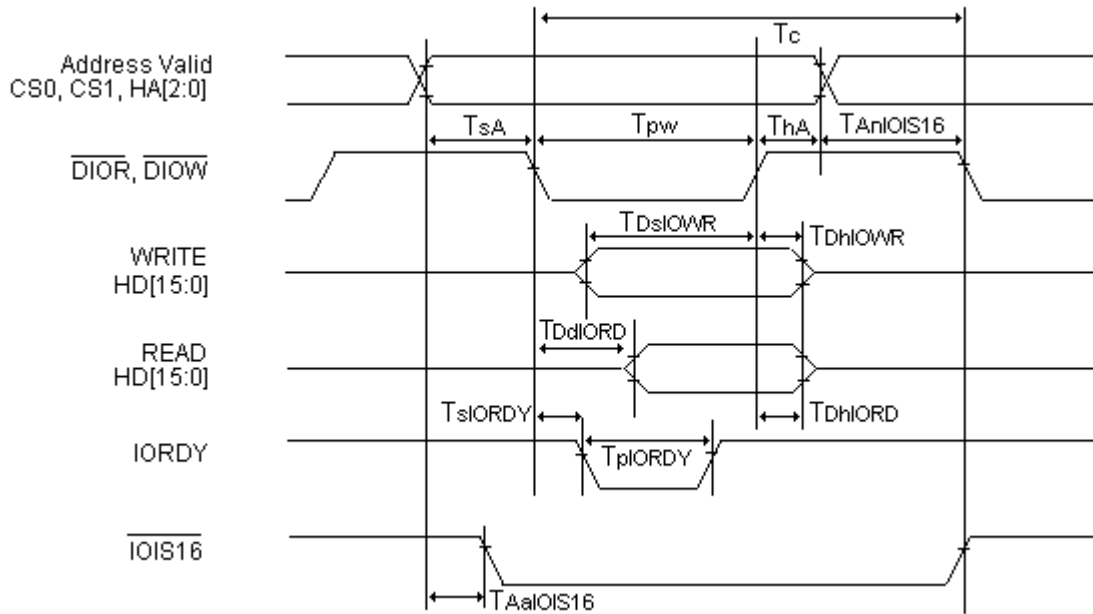

Figure 7: Timing Diagram, PIO Mode 4

Table 9: Timing Specifications, PIO Mode 4

Symbol	Parameter	Min	Max	Unit
T_c	Cycle Time	120	-	ns
T_{sA}	Address Setup before DIOR#, DIO#	25	-	ns
T_{ThA}	Address Hold following DIOR#, DIO#	10	-	ns
T_{pw}	DIOR#, DIO# Pulse Width	60	-	ns
$T_{D_{sIOWR}}$	Data Setup before DIO#	20	-	ns
$T_{D_{hIOWR}}$	Data Hold following DIO#	10	-	ns
$T_{D_{dIORD}}$	Data Delay after DIOR#	-	20	ns
$T_{D_{hIORD}}$	Data Hold following DIOR#	5	-	ns
$T_{AaIOIS16}$	IOIS16# Delay Falling from Address	-	15	ns
$T_{AnIOIS16}$	IOIS16# Delay Rising from Address	-	15	ns
T_{sIORDY}	IORDY Setup Time	-	35	ns
T_{pIORDY}	IORDY Pulse Time	-	1250	ns

9. Ordering Information

MD105X-DXXX

where:

- MD** M-Systems' DiskOnChip family
- 10** DiskOnChip IDE Pro
- 5X** Vertical alignment, IDE connector
 - 0: 40-pin IDE connector
 - 1: 44-pin IDE connector
- DXXX** Capacity (MB): 16, 32, 64, 128, 256

Refer to Table 10 for the combinations currently available and the associated order numbers.

Table 10: Available Combinations

Ordering Information	Capacity (MB)	Mechanical Alignment	Connector
MD1050-D16	16	Vertical	40-pin
MD1050-D32	32	Vertical	40-pin
MD1050-D64	64	Vertical	40-pin
MD1050-D128	128	Vertical	40-pin
MD1050-D256	256	Vertical	40-pin
MD1051-D16	16	Vertical	44-pin
MD1051-D32	32	Vertical	44-pin
MD1051-D64	64	Vertical	44-pin
MD1051-D128	128	Vertical	44-pin
MD1051-D256	256	Vertical	44-pin

Note: The ordering information for the IDE Pro 40-pin power cable is: DOC-IDE40-CABLE.

How to Contact Us

Website:<http://www.m-sys.com>**General Information:**info@m-sys.com**Technical Information:**techsupport@m-sys.com**USA**

M-Systems Inc.
8371 Central Ave, Suite A
Newark CA 94560
Phone: +1-510-494-2090
Fax: +1-510-494-5545

Taiwan

M-Systems Asia, Ltd.
Room B, 13 F, No. 133 Sec. 3
Min Sheng East Road
Taipei, Taiwan R.O.C.
Phone: +886-2-8770-6226
Fax: +886-2-8770-6295

Japan

M-Systems Japan Inc.
Arakyu Bldg., 5F
2-19-2 Nishi-Gotanda Shinagawa-ku
Tokyo 141-0031
Phone: +81-3-5437-5739
Fax: +81-3-5437-5759

China

M-Systems China Ltd.
25A International Business Commercial Bldg.
Nanhu Rd., Lou Hu District
Shenzhen, China 518001
Phone: +86-755-2519-4732
Fax: +86-755-2519-4729

Europe and Israel

M-Systems Ltd.
7 Atir Yeda St.
Kfar Saba 44425, Israel
Phone: +972-9-764-5000
Fax: +972-3-548-8666

© 2002 M-Systems Flash Disk Pioneers, Ltd. All rights reserved.

This document is for information use only and is subject to change without prior notice. M-Systems Flash Disk Pioneers Ltd. assumes no responsibility for any errors that may appear in this document. No part of this document may be reproduced, transmitted, transcribed, stored in a retrievable manner or translated into any language or computer language, in any form or by any means, electronic, mechanical, magnetic, optical, chemical, manual or otherwise, without prior written consent of M-Systems.

M-Systems products are not warranted to operate without failure. Accordingly, in any use of the Product in life support systems or other applications where failure could cause injury or loss of life, the Product should only be incorporated in systems designed with appropriate and sufficient redundancy or backup features.

Contact your local M-Systems sales office or distributor, or visit our website at www.m-sys.com to obtain the latest specifications before placing your order.

DiskOnChip[®], DiskOnChip Millennium[®] and TrueFFS[®] are registered trademarks of M-Systems. DiskOnKey[™], FFD[™] and SuperMAP[™] are trademarks of M-Systems. Other product names mentioned in this document may be trademarks or registered trademarks of their respective owners and are hereby acknowledged.