

SBC

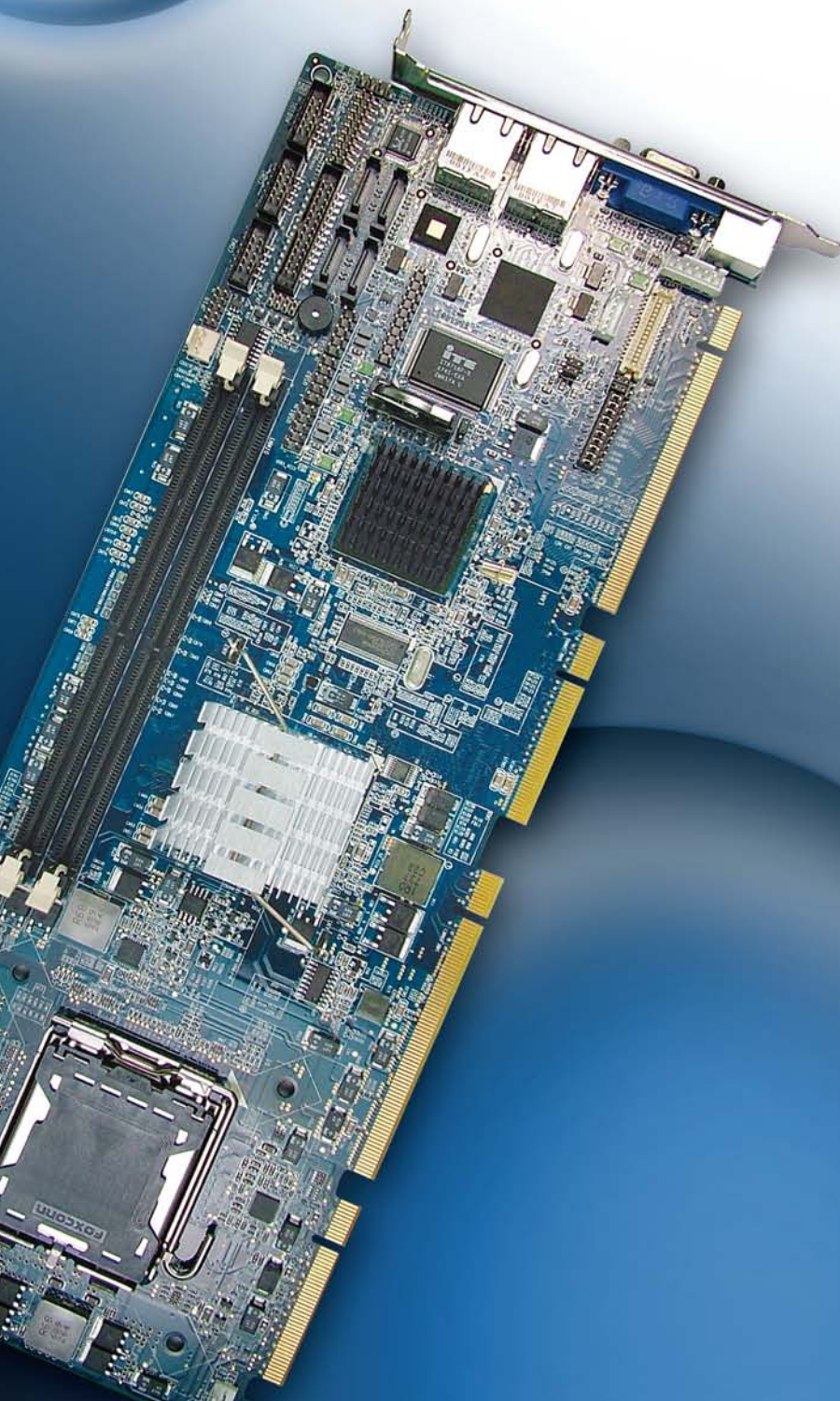

PSB-701LF

Socket 775 Intel® Core™ 2 Duo / Core™ 2 Quad
PICMG 1.3 CPU Card w /
VGA / Sound / 2LAN

Features and Benefits:

- Support Intel® Core™ 2 Quad, Core™ 2 Duo and Celeron® processors
- Equipped with Intel® Q35 Chipset with FSB 800/1066/1333MHz
- Memory Supports DDRII 667/800 SDRAM up to 4GB
- Supports 2 x 10/100/1000 Mbps Ethernet Connection, PICMG 1.3 compliance
- Supports Trusted Platform Module Applications such as ATM, multimedia systems, digital image storage servers and more



PROTECH SYSTEMS

It's the right choice

No. 24, Lane 365, Yang Guang St., Nei Hu District, Taipei 114, Taiwan

Tel: +886-2-8751-1111

Fax: +886-2-8751-1199

Email: sales@protech.com.tw

<http://www.protech.com.tw>



ISO CERTIFIED

9001 | 14001

PSB-701LF

Socket 775 Intel® Core™ 2 Duo/ Core™ 2 Quad PICMG 1.3 CPU Card w/ VGA/Sound/2LAN

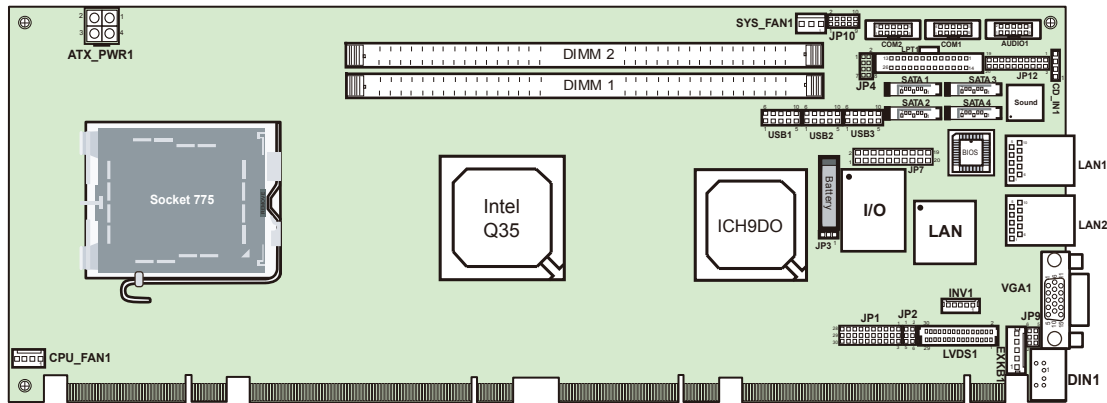

Specifications

System	
CPU Type	Intel® Core™ 2 Quad/ Core™ 2 Duo/ Celeron® CPU with LGA775 CPU socket (support Intel® 65nm, 45nm Process Technology CPU)
CPU Frequency	Core™ 2 Quad: 2.4~2.66GHz Core™ 2 Duo: 1.8~3.0GHz Celeron® : 1.6~2.0GHz
Chipset	Intel® Q35 + ICH9DO (FSB: 800/1066/1333MHz)
DRAM	2 x 240-Pin DDR2 DIMM, support Dual channel memory architecture and DDR2 667/800MHz up to 4GB
BIOS	Phoenix-Award PnP BIOS, with 4MB SPI flash
Watchdog	1~255 secs Watchdog timer selectable Clear/Reset/NMI
Power Supply	Support ATX power
Power Requirement	+5V, +12V, +3.3V, +5Vsb (from Backplane)
Power Consumption	+5V: 3.3A, +12V: 5.63A, +3.3V: 1.64A, 5VSB: 0.26A (Intel® Core™ 2 Quad Q6700 2.66GHz)
Dimension	338.5 mm x 126 mm (13.33" x 4.96")
Certificate	CE, FCC

I/O Chipset

SATA Interface	6 x S-ATA II connector (Raid 0,1,10,5) 4 ports on board; 2 ports signals via SHB C to backplane
TPM	TPM1.2 1 with 20-pin header on board for TPM (Trusted Platform Module)
Serial Port	2 x COM ports, COM 1 for RS232, COM 2 for RS232/422/485 (for 16550 compatible type of UART)

Keyboard	Mini DIN connector or external connector
Mouse	Mini DIN connector (selectable w / KB) or Y-cable
LAN	LAN 1: Intel® 82566DM (10/100/1000 Mbps) LAN 2: Intel® 82573L (10/100/1000 Mbps) Support Wake-on-LAN with ATX power
Audio	HD Codec, Realtek ALC262 with 10-pin header for Line-in/ Line-out/ MIC
USB	10 x USB 2.0 6 ports pinheader on board; 4 ports signals via SHB C to backplane

Display

Graphic	Built-in Intel® Q35, share system memory support CRT, LVDS (LVDS transfer from SDVO)
LCD Interface	18/24-bit LVDS

Environment

Operation Temp.	0°~60°C (32°~140°F)
Storage Temp.	-40°~85°C (-40°~185°F)
Humidity	Operation humidity 20~90%, Storage humidity 20~95%

Ordering Information

PSB-701LF-P0205	PICMG 1.3 LGA775 Core™ 2 Duo CPU Card with VGA /Audio /2 x COM /2 x LAN (10/100/1000Mbps) / LVDS
PSB-701LF-P0905	PICMG 1.3 LGA775 Core™ 2 Duo CPU Card with VGA /Audio /2 x COM /2 x LAN (10/100/1000Mbps) W/O LVDS

All of trademarks and brand names are the property of their owners. Trademark "Protech" is the property of Protech Systems Co., Ltd.
All information contained in this document is subject to change without any prior notice. This catalog is copyrighted in Oct. 2010.