

1769 Compact I/O Modules Specifications



Catalog Numbers 1769 series

Topic	Page
Available 1769 I/O Modules	4
Digital I/O Modules	6
Analog I/O Modules	7
Specialty I/O Modules	8
Module Specifications	9
Compact I/O Accessories	129
Compact I/O Mounting Dimensions	133
Compact I/O Mounting Dimensions	133
PanelConnect Modules	134

The 1769 Compact I/O modules can be used with a CompactLogix controller, as well as for expansion I/O in a MicroLogix 1500 controller assembly or in an assembly with a 1769-ADN DeviceNet adapter module. Unless connected to a MicroLogix 1500 base, each bank of I/O modules must include its own power supply.

Install the I/O modules on a panel with two mounting screws or on a DIN rail. The modules mechanically lock together by means of a tongue-and-groove design and have an integrated communication bus that is connected from module to module by a moveable bus connector.

Important User Information

Solid state equipment has operational characteristics differing from those of electromechanical equipment. Safety Guidelines for the Application, Installation and Maintenance of Solid State Controls (publication [SGI-1.1](#) available from your local Rockwell Automation sales office or online at <http://www.rockwellautomation.com/literature/>) describes some important differences between solid state equipment and hard-wired electromechanical devices. Because of this difference, and also because of the wide variety of uses for solid state equipment, all persons responsible for applying this equipment must satisfy themselves that each intended application of this equipment is acceptable.

In no event will Rockwell Automation, Inc. be responsible or liable for indirect or consequential damages resulting from the use or application of this equipment.

The examples and diagrams in this manual are included solely for illustrative purposes. Because of the many variables and requirements associated with any particular installation, Rockwell Automation, Inc. cannot assume responsibility or liability for actual use based on the examples and diagrams.

No patent liability is assumed by Rockwell Automation, Inc. with respect to use of information, circuits, equipment, or software described in this manual.

Reproduction of the contents of this manual, in whole or in part, without written permission of Rockwell Automation, Inc., is prohibited.

Throughout this manual, when necessary, we use notes to make you aware of safety considerations.

WARNING



Identifies information about practices or circumstances that can cause an explosion in a hazardous environment, which may lead to personal injury or death, property damage, or economic loss.

IMPORTANT

Identifies information that is critical for successful application and understanding of the product.

ATTENTION



Identifies information about practices or circumstances that can lead to personal injury or death, property damage, or economic loss. Attentions help you identify a hazard, avoid a hazard, and recognize the consequence

SHOCK HAZARD



Labels may be on or inside the equipment, for example, a drive or motor, to alert people that dangerous voltage may be present.

BURN HAZARD



Labels may be on or inside the equipment, for example, a drive or motor, to alert people that surfaces may reach dangerous temperatures.

Rockwell Automation, Rockwell Software, Allen-Bradley, Compact I/O, CompactLogix, MicroLogix, RSLogix 5000, SCANport, PowerFlex, 1336 PLUS II, PowerFlex 4, PanelConnect, and TechConnect are trademarks of Rockwell Automation, Inc.

.Trademarks not belonging to Rockwell Automation are property of their respective companies.

Each I/O module includes a built-in removable terminal block with finger-safe cover for connections to I/O sensors and actuators. The terminal block is behind a door at the front of the module. I/O wiring can be routed from beneath the module to the I/O terminals.

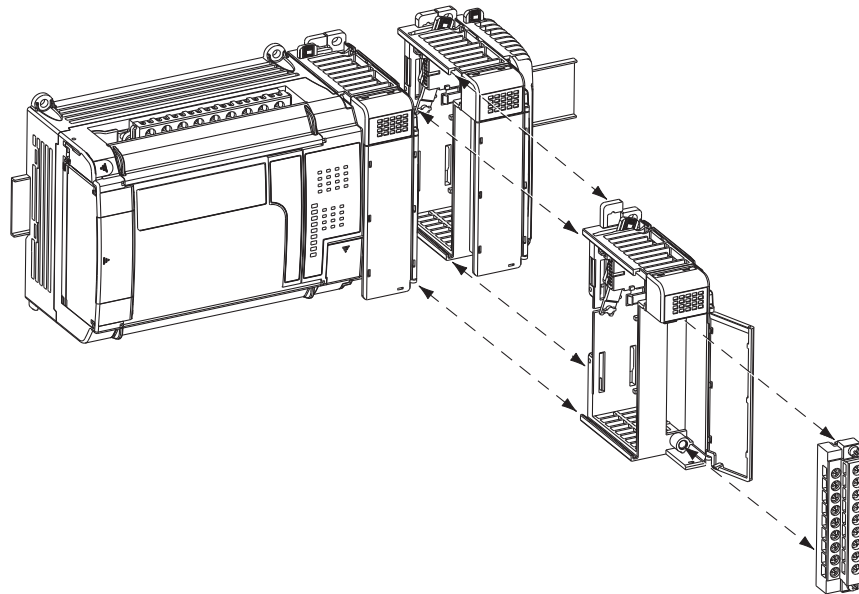

- Once the modules are locked together, the system becomes a rugged assembly.
- Upper and lower tongue-and-groove slots guide the module during installation and secure the module within the system.
- Removable terminal blocks help ease the wiring task.
- Self-lifting, field-wire pressure plates cut installation time.
- The patented bus connector with locking function enables reliable module and system communication.
- A color bar is provided on the front of the module.
- Digital and field circuits are optically isolated.

Available 1769 I/O Modules

I/O Type	Cat. No.	Page	Cat. No.	Page
AC digital	1769-IA8I	9	1769-OA8	65
	1769-IA16	11	1769-OA16	68
	1769-IM12	42		
DC digital	1769-IG16	40	1769-OB8	71
	1769-IQ16	44	1769-OB16	73
	1769-IQ16F	46	1769-OB16P	76
	1769-IQ32	48	1769-OB32	79
	1769-IQ32T	50	1769-OB32T	82
	1769-IQ6XOW4	52	1769-OG16	102
			1769-OV16	104
		1769-OV32T	107	
Contact	1769-OW8	109	1769-OW16	113
	1769-OW8I	111		
Analog	1769-IF4	13	1769-OF2	84
	1769-IF4I	16	1769-OF4	87
	1769-IF4XOF2	20	1769-OF4CI	90
	1769-IF4FXOF2F	25	1769-OF4VI	93
	1769-IF8	30	1769-OF8C	96
	1769-IF16C	34	1769-OF8V	99
	1769-IF16V	37		
	1769-IR6	55		
	1769-IT6	61		
Specialty	1769-ARM	115	1769-BOOLEAN	118
	1769-ASCII	116	1769-HSC	123

Environmental Specifications - 1769 I/O Modules

Attribute	1769-IA8I, 1769-IA16, 1769-IM12, 1769-OA8, 1769-OA16, 1769-IQ16, 1769-IQ16F, 1769-IQ32, 1769-IQ6XOW4, 1769-OB8, 1769-OB16, 1769-OB16P, 1769-OB32, 1769-OV16, 1769-OW8, 1769-OW8I, 1769-OW16 1769-IF4, 1769-IF4XOF2, 1769-IR6, 1769-IT6 1769-ARM, 1756-HSC	1769-IG16, 1769-IQ32T, 1769-OB32T, 1769-OG16, 1769-OV32T 1769-IF4I, 1769-IF8, 1769-IF16C, 1769-IF16V, 1769-OF2, 1769-OF4CI, 1769-OF4VI, 1769-OF8C, 1769-OF8V, 1769-IF4XOF2F 1769-ASCII, 1769-BOOLEAN
Temperature, operating IEC 60068-2-1 (Test Ad, Operating Cold), IEC 60068-2-2 (Test Bd, Operating Dry Heat), IEC 60068-2-14 (Test Nb, Operating Thermal Shock)	0...60 °C (32...140 °F)	0...60 °C (32...140 °F)
Temperature, storage IEC 60068-2-1 (Test Ab, Unpackaged Nonoperating Cold), IEC 60068-2-2 (Test Bb, Unpackaged Nonoperating Dry Heat), IEC 60068-2-14 (Test Na, Unpackaged Nonoperating Thermal Shock)	-40...85 °C (-40...185 °F)	-40...85 °C (-40...185 °F)
Relative humidity IEC 60068-2-30 (Test Db, Unpackaged Nonoperating Damp Heat)	5...95% noncondensing	5...95% noncondensing
Vibration IEC 60068-2-6 (Test Fc, Operating)	Operating: 5 g @ 10...500 Hz Relay operating: 2 g	5 g @ 10...500 Hz
Shock, operating IEC 60068-2-27 (Test Ea, Unpackaged Shock)	Panel mount 30 g DIN rail mount 20 g	Panel mount 30 g DIN rail mount 20 g
Shock, relay operating IEC 60068-2-27 (Test Ea, Unpackaged Shock)	Panel mount 7.5 g DIN rail mount 5 g	—
Shock, nonoperating IEC 60068-2-27 (Test Ea, Unpackaged Shock)	Panel mount 40 g DIN rail mount 30 g	Panel mount 40 g DIN rail mount 30 g

Place Compact I/O Modules You can DIN-rail or panel mount the controller and I/O modules. The number of local I/O modules supported depends on the controller.

This Controller	Supports	Location	Considerations
1769-L23E-QB1B 1769-L23E-QBFC1B 1769-L23-QBFC1B	2 local modules	Right side of the packaged controller	The additional modules are connected directly to the packaged controller. There are no additional banks of local I/O.
1769-L35CR 1769-L35E	30 local modules	3 separate banks	Each module uses a set amount of backplane memory, in addition to the data that the module stores or transfers.
1769-L32C 1769-L32E 1769-L31	16 local modules	3 separate banks	The additional banks are powered by standard 1769 power supplies and connect to the main rack by using standard 1769 expansion cables.
1768-L43	16 local modules	3 separate banks	As many as eight 1769 local modules can be attached to the 1768 backplane. The remaining modules can be in one or two additional I/O banks. The additional banks are powered by standard 1769 power supplies and connect to the main rack by using standard 1769 expansion cables.
1768-L45	30 local modules	3 separate banks	

Each 1769 I/O module has a distance rating. In 1769 systems, the distance rating is the number of modules between the specific module and the 1769 power supply. In a 1768 system, the distance rating is the number of modules between the specific I/O module and the 1768 controller.

Digital I/O Modules

Choose digital I/O modules when you need these features.

Type	Description
Input	<p>An input module responds to an input signal in the following manner:</p> <ul style="list-style-type: none"> • Input filtering limits the effect of voltage transients caused by contact bounce and/or electrical noise. If not filtered, voltage transients could produce false data. All input modules use input filtering. • Optical isolation shields logic circuits from possible damage due to electrical transients. • Logic circuits process the signal. • An input indicator turns on or off indicating the status of the corresponding input device.
Output	<p>An output module controls the output signal in the following manner:</p> <ul style="list-style-type: none"> • Logic circuits determine the output status. • An output indicator displays the status of the output signal. • Optical isolation separates module logic and bus circuits from field power. • The output driver turns the corresponding output on or off.

Most output modules have built-in surge suppression to reduce the effects of high-voltage transients. Use an additional suppression device if an output is being used to control inductive devices, such as relays, motor starters, solenoids, or motors.

Additional suppression is especially important if your inductive device is in series with or parallel to hard contacts, such as pushbuttons or selector switches. Add a suppression device directly across the coil of an inductive device to reduce the effects of voltage transients caused by interrupting the current to that device and to prolong the life of the switch contacts.

Analog I/O Modules

Choose analog, thermocouple, or RTD modules for these features:

- Individually configurable channels
- Ability to individually enable and disable channels
- On-board scaling
- Autocalibration of inputs
- Online configuration
- Selectable input filters
- Over-range and under-range detection and indication
- Selectable response to a broken input sensor
- Selectable power source
- Input modules offer both single-ended or differential inputs
- Ability to direct output device operation during an abnormal condition
- High accuracy ratings

The data can be configured on board each module as:

- Engineering Units in volts or milliamps.
- Scaled-for-PID.
- Percent of range.
- Raw/Proportional Data for maximum resolution.

Specialty I/O Modules

These specialty modules are available.

Cat. No.	Description
1769-ARM	Use a 1769-ARM address reserve module to reserve module slots. After creating an I/O configuration and user program, you can remove and replace any I/O module in the system with a 1769-ARM module once you inhibit the removed module in RSLogix 5000 programming software.
1769-ASCII	The 1769-ASCII module, a general purpose two-channel ASCII interface, provides a flexible network interface to a wide variety of RS-232, RS-485, and RS-422 ASCII devices. The module provides the communication connections to the ASCII device.
1769-BOOLEAN	Use the 1769-BOOLEAN module in applications that require repeatability, such as material handling and packaging, when there is a requirement to activate an output based on an input's transition. If the Boolean expression is true, the output is directed to the ON state. If the Boolean expression is false, the output channel is directed to the OFF state. There are four operators that you can configure as OR, AND, XOR, or none.
1769-HSC	Use the 1769-HSC module when you need: <ul style="list-style-type: none"> • a counter module that is capable of reacting to high-speed input signals. • to generate rate and time-between-pulses (pulse interval) data. • as many as two channels of quadrature or four channels of pulse/count inputs.
1769-SM1	The Compact I/O to DPI/SCANport module connects to PowerFlex 7-class drives, other DPI-based host devices, and SCANport-based host devices such as 1305 and 1336 PLUS II drives.
1769-SM2	The Compact I/O to DSI/Modbus module connects to PowerFlex 4-class drives and to other Modbus RTU slave devices, such as PowerFlex 7-class drives with 20-COMM-H RS485 HVAC adapters.

1769-IA8I

Compact individually-isolated 120V AC input module

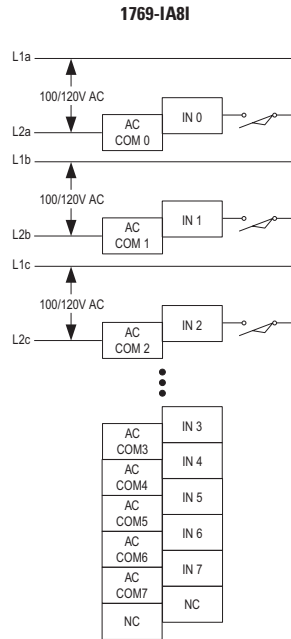

Technical Specifications - 1769-IA8I

Attribute	1769-IA8I
Inputs	8 individually isolated
Voltage category	100/120V AC
Operating voltage range	79...132V AC, 47...63 Hz
Input delay, on	20 ms
Input delay, off	20 ms
Current draw @ 5.1V	90 mA
Heat dissipation, max	1.81 W
Off-state voltage, max	20V AC
Off-state current, max	2.5 mA
On-state voltage, min	79V AC
On-state current, min	5 mA @ 74V AC
On-state current, max	12 mA @ 120V AC
Inrush current, max ⁽¹⁾	250 mA
Input impedance, max	12 k Ω @ 50 Hz 10 k Ω @ 60 Hz
Isolation voltage	Verified by one of the following dielectric tests: 1517V AC for 1 s or 2145V DC for 1 s, input point to bus and group to group 132V AC working voltage (IEC Class 2 reinforced insulation)
Weight, approx.	270 g (0.60 lb)

Technical Specifications - 1769-IA8I

Attribute	1769-IA8I
Dimensions (HxWxD), approx.	118 x 35 x 87 mm (4.65 x 1.38 x 3.43 in.) Height with mounting tabs 138 mm (5.43 in.)
Slot width	1
Module location	DIN rail or panel mount
Power supply	1769-PA2, 1769-PB2, 1769-PA4, 1769-PB4
Power supply distance rating	8 modules
Terminal screw torque	0.68 N•m (6 lb•in)
Retaining screw torque	0.46 N•m (4.1 lb•in)
Wire size	(22...14 AWG) solid (22...16 AWG) stranded
Wire type	Cu-90 °C (194 °F)
IEC input compatibility	Type 1+
Replacement terminal block	1769-RTBN18 (1 per kit)
Replacement door label	1769-RL1 (2 per kit)
Replacement door	1769-RD (2 per kit)
Vendor ID code	1
Product type code	7
Product code	81
Enclosure type rating	None (open-style)

⁽¹⁾ A current limiting resistor can be used to limit inrush current; however, the operating characteristics of the AC input circuit will be affected. If a 6.8 kΩ (2.5 W minimum) resistor is placed in series with the input, the inrush current is reduced to 35 mA. In this configuration, the minimum on-state voltage increases to 92V AC. Before adding the resistor in a hazardous environment, be sure to consider the operating temperature of the resistor and the temperature limits of the environment. The operating temperature of the resistor must remain below the temperature limit of the environment.

Certifications - 1769-IA8I

Certification ⁽¹⁾	1769-IA8I
c-UL	C-UL certified (under CSA C22.2 No. 142) UL 508 listed Class I, Division 2 Group A,B,C,D Hazardous Locations (UL 1604, C-UL under CSA C22.2 No. 213)
CE	CE compliant for all applicable directives

⁽¹⁾ When marked. See the Product Certification link at <http://www.ab.com> for Declarations of Conformity, Certificates, and other certification details.

1769-IA16

Compact 120V AC input module

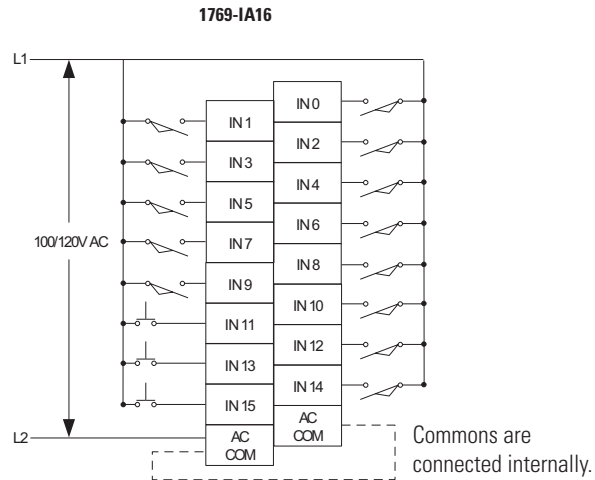

Technical Specifications - 1769-IA16

Attribute	1769-IA16
Inputs	16 (16 points/group, internally connected commons)
Voltage category	100/120V AC
Operating voltage range	79...132V AC, 47...63 Hz
Input delay, on	20 ms
Input delay, off	20 ms
Current draw @ 5.1V	115 mA
Heat dissipation, max	3.30 W
Off-state voltage, max	20V AC
Off-state current, max	2.5 mA
On-state voltage, min	79V AC
On-state current, min	5 mA @ 74V AC
On-state current, max	12 mA @ 120V AC
Inrush current, max ⁽¹⁾	250 mA
Input impedance, max	12 k Ω @ 50 Hz 10 k Ω @ 60 Hz
Isolation voltage	Verified by one of the following dielectric tests: 1517V AC for 1 s or 2145V DC for 1 s, input point to bus 132V AC working voltage (IEC Class 2 reinforced insulation)
Weight, approx.	280 g (0.61 lb)
Dimensions (HxWxD), approx.	118 x 35 x 87 mm (4.65 x 1.38 x 3.43 in.) Height with mounting tabs 138 mm (5.43 in.)
Slot width	1
Module location	DIN rail or panel mount
Power supply	1769-PA2, 1769-PB2, 1769-PA4, 1769-PB4

Technical Specifications - 1769-IA16

Attribute	1769-IA16
Power supply distance rating	8 modules
Terminal screw torque	0.68 N•m (6 lb•in)
Retaining screw torque	0.46 N•m (4.1 lb•in)
Wire size	(22...14 AWG) solid (22...16 AWG) stranded
Wire type	Cu-90 °C (194 °F)
IEC input compatibility	Type 1+
Replacement terminal block	1769-RTBN18 (1 per kit)
Replacement door label	1769-RL1 (2 per kit)
Replacement door	1769-RD (2 per kit)
Vendor ID code	1
Product type code	7
Product code	82
Enclosure type rating	None (open-style)

⁽¹⁾ A current limiting resistor can be used to limit inrush current; however, the operating characteristics of the AC input circuit will be affected. If a 6.8 kΩ (2.5 W minimum) resistor is placed in series with the input, the inrush current is reduced to 35 mA. In this configuration, the minimum on-state voltage increases to 92V AC. Before adding the resistor in a hazardous environment, be sure to consider the operating temperature of the resistor and the temperature limits of the environment. The operating temperature of the resistor must remain below the temperature limit of the environment.

Certifications - 1769-IA16

Certification ⁽¹⁾	1769-IA16
c-UL	C-UL certified (under CSA C22.2 No. 142) UL 508 listed Class I, Division 2 Group A,B,C,D Hazardous Locations (UL 1604, C-UL under CSA C22.2 No. 213)
CE	CE compliant for all applicable directives

⁽¹⁾ When marked. See the Product Certification link at <http://www.ab.com> for Declarations of Conformity, Certificates, and other certification details.

1769-IF4

Compact voltage/current analog input module

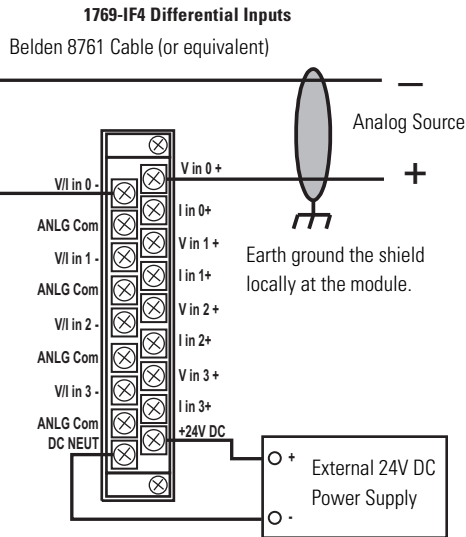

The external power supply must be rated Class 2, with a 24V DC range of 20.4...26.4V DC and 60 mA minimum. Series B and later modules support this option.

1769-IF4 Single-ended Sensor/Transmitter Inputs

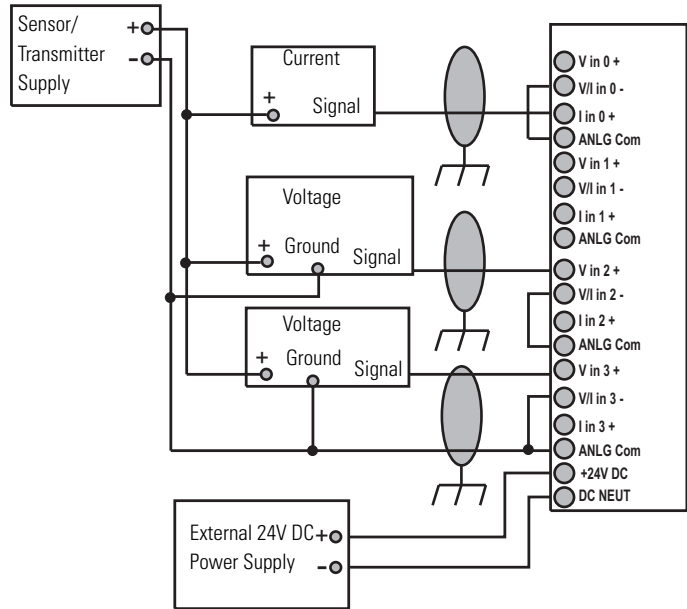

1769-IF4 Mixed Transmitter Inputs

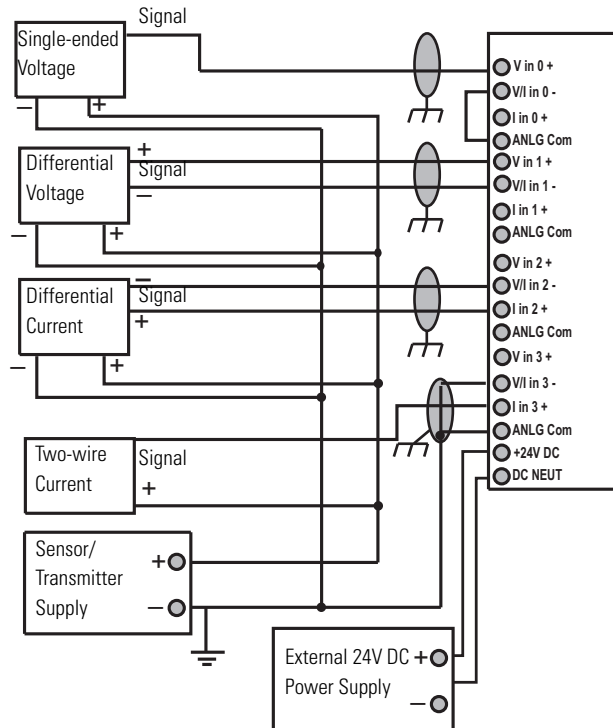

Technical Specifications - 1769-IF4

Attribute	1769-IF4
Inputs	4 differential or single-ended
Input range	±10V 0...10V 0...5V 1...5V 0...20 mA 4...20 mA
Full scale range ⁽¹⁾	±10.5V -0.5...10.5V -0.5...5.25V 0.5...5.25V 0...21 mA 3.2...21 mA
Current draw @ 5.1V	120 mA
Current draw @ 24V	60 mA
Heat dissipation, max	2.52 W
Converter type	Delta Sigma
Resolution ⁽²⁾	14 bits (unipolar) 14 bits plus sign (bipolar)
Rated working voltage ⁽³⁾	30V AC/30V DC
Common mode voltage range ⁽⁴⁾	±10V DC max per channel
Common mode rejection	> 60 dB @ 50 and 60 Hz with the 50 or 60 Hz filter selected, respectively
Normal mode rejection ratio	-50 dB @ 50 and 60 Hz with the 50 or 60 Hz filter selected, respectively
Input impedance	Voltage: 220 kΩ Current: 250 Ω
Accuracy ⁽⁵⁾	Voltage: ±0.2% full scale @ 25 °C (77 °F) Current: ±0.35% full scale @ 25 °C (77 °F)
Accuracy drift with temperature	Voltage: ±0.003% per °C Current: ±0.0045% per °C
Nonlinearity	±0.03%
Repeatability ⁽⁶⁾	±0.03%
Module error	Voltage: ±0.3% Current: ±0.5%
Overload at input terminals, max ⁽⁷⁾	Voltage: ±30V DC continuous, 0.1 mA Current: ±32 mA continuous, ±7.6V DC
Isolation voltage	500V AC or 710V DC for 1 minute (qualification test), group to bus 30V AC/30V DC working voltage (IEC Class 2 reinforced insulation)
Weight, approx.	300 g (0.65 lb)
Dimensions (HxWxD), approx.	118 x 35 x 87 mm (4.65 x 1.38 x 3.43 in.) Height with mounting tabs 138 mm (5.43 in.)
Slot width	1
Module location	DIN rail or panel mount
Power supply	1769-PA2, 1769-PB2, 1769-PA4, 1769-PB4
Optional 24V DC Class 2 power supply voltage range ⁽⁸⁾	20.4...26.4V DC

Technical Specifications - 1769-IF4

Attribute	1769-IF4
Power supply distance rating	8 modules
Terminal screw torque	0.68 N•m (6 lb•in)
Retaining screw torque	0.46 N•m (4.1 lb•in)
Wire size	(22...14 AWG) solid (22...16 AWG) stranded
Wire type	Cu-90 °C (194 °F)
Replacement terminal block	1769-RTBN18 (1 per kit)
Replacement door label	1769-RL2 series B (2 per kit)
Replacement door	1769-RD (2 per kit)
Vendor ID code	1
Product type code	10
Product code	35
Enclosure type rating	None (open-style)

(1) The over- or under-range flag will come on when the normal operating range (over/under) is exceeded. The module will continue to convert the analog input up to the maximum full scale range. The flag automatically resets when within the normal operating range.

(2) Resolution is dependent upon your filter selection. The maximum resolution is achieved with either the 50 or 60 Hz filter selected.

(3) Rated working voltage is the maximum continuous voltage that can be applied at the input terminal, including the input signal and the value that floats above ground potential (for example, 10V DC input signal and 20V DC potential above ground).

(4) For proper operation, both the plus and minus input terminals must be within $\pm 10V$ DC of analog common.

(5) Includes offset, gain, nonlinearity, and repeatability error terms.

(6) Repeatability is the ability of the input module to register the same reading in successive measurements for the same input signal.

(7) Damage may occur to the input circuit if this value is exceeded.

(8) If the optional 24V DC Class 2 power supply is used, the 24V DC current draw from the bus is 0 mA.

Response Speed - 1769-IF4

Filter Frequency	Cut-off Frequency	Step Response	Channel Update
50 Hz	13.1 Hz	60 ms	22 ms
60 Hz	15.7 Hz	50 ms	19 ms
250 Hz	65.5 Hz	12 ms	6 ms
500 Hz	131 Hz	6 ms	4 ms

Certifications - 1769-IF4

Certification ⁽¹⁾	1769-IF4
c-UL	C-UL certified (under CSA C22.2 No. 142) UL 508 listed Class I, Division 2 Group A,B,C,D Hazardous Locations (UL 1604, C-UL under CSA C22.2 No. 213)
CE	CE compliant for all applicable directives

⁽¹⁾ When marked. See the Product Certification link at <http://www.ab.com> for Declarations of Conformity, Certificates, and other certification details.

1769-IF4I

Compact voltage/current analog, individually-isolated input module

1769-IF4I Differential Inputs

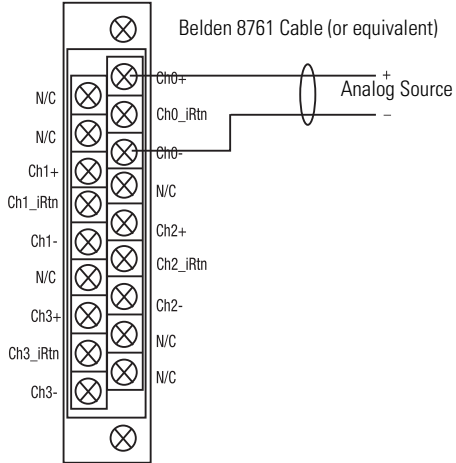

1769-IF4I Single-ended Sensor/Transmitter Inputs

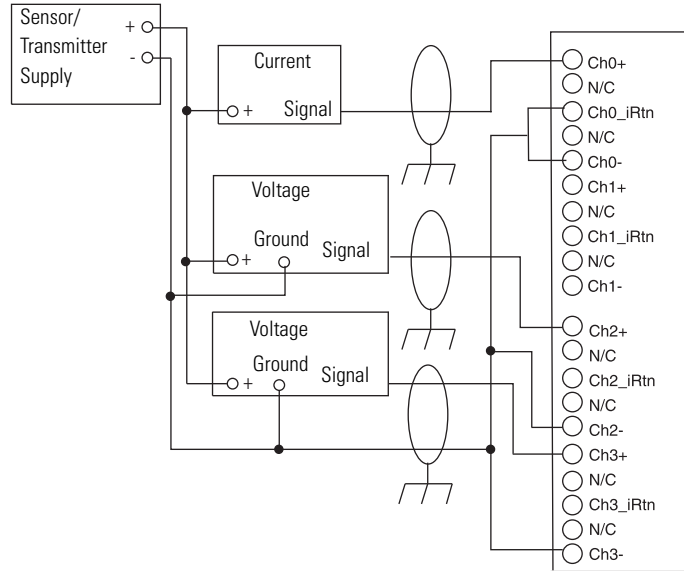

1769-IF4I Mixed Transmitter Inputs

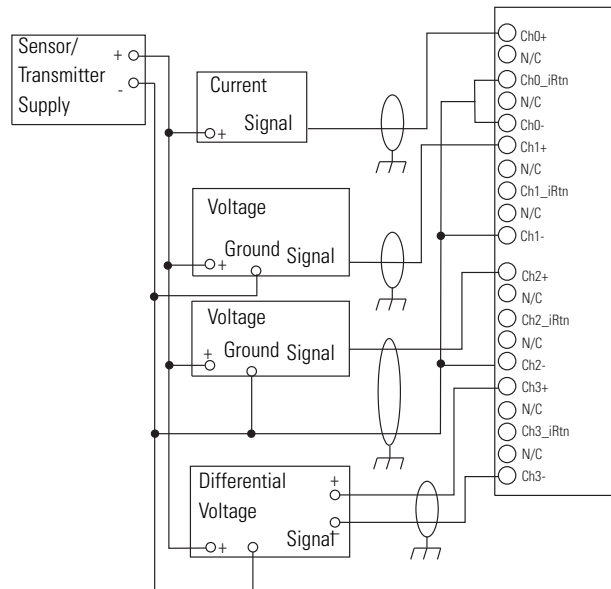

Technical Specifications - 1769-IF4I

Attribute	1769-IF4I
Inputs	4 isolated differential
Input range	±10V 0...10V 0...5V 1...5V 0...20 mA 4...20 mA
Full scale range ⁽¹⁾	±10.5V -0.5...10.5V -0.5...5.25V 0.5...5.25V 0...21 mA 3.2...21 mA
Current draw @ 5.1V	145 mA
Current draw @ 24V	125 mA
Heat dissipation, max	3.0 W
Converter type	Delta Sigma
Resolution ⁽²⁾	16 bits (unipolar) 15 bits plus sign (bipolar)
Rated working voltage ⁽³⁾	30V AC/30V DC
Common mode voltage range ⁽⁴⁾	±10V DC max per channel
Common mode rejection	> 60 dB @ 50 and 60 Hz with the 10 Hz filter selected
Normal mode rejection ratio	-50 dB @ 50 and 60 Hz with the 10 Hz filter selected
Input impedance	Voltage: 1 MΩ Current: 249 Ω
Accuracy ⁽⁵⁾	Voltage: ±0.2% full scale @ 25 °C (77 °F) Current: ±0.35% full scale @ 25 °C (77 °F)
Accuracy drift with temperature	Voltage: ±0.003% per °C Current: ±0.0045% per °C
Nonlinearity	±0.03%
Repeatability ⁽⁶⁾	±0.03%
Module error	Voltage: ±0.3% Current: ±0.5%
Overload at input terminals, max ⁽⁷⁾	Voltage: ±24V DC continuous, 0.1 mA Current: ±28 mA continuous, ±7.6V DC
Isolation voltage	500V AC or 710V DC for 1 minute (qualification test), group to bus 30V AC/30V DC working voltage (IEC Class 2 reinforced insulation) 500V AC or 710V DC for 1 minute or 250V continuous (optical and magnetic), channel to rack and channel to channel
Weight, approx.	300 g (0.65 lb)
Dimensions (HxWxD), approx.	118 x 35 x 87 mm (4.65 x 1.38 x 3.43 in.) Height with mounting tabs 138 mm (5.43 in.)
Slot width	1
Module location	DIN rail or panel mount
Power supply	1769-PA2, 1769-PB2, 1769-PA4, 1769-PB4
Power supply distance rating	8 modules

Technical Specifications - 1769-IF4I

Attribute	1769-IF4I
Terminal screw torque	0.68 N•m (6 lb•in)
Retaining screw torque	0.46 N•m (4.1 lb•in)
Wire size	(22...14 AWG) solid (22...16 AWG) stranded
Wire type	Cu-90 °C (194 °F)
Replacement terminal block	1769-RTBN18 (1 per kit)
Replacement door label	1769-RL2 series B (2 per kit)
Replacement door	1769-RD (2 per kit)
Vendor ID code	1
Product type code	10
Product code	44
Enclosure type rating	None (open-style)

(1) The over- or under-range flag will come on when the normal operating range (over/under) is exceeded. The module will continue to convert the analog input up to the maximum full scale range. The flag automatically resets when within the normal operating range.

(2) Resolution is dependent upon your filter selection. The maximum resolution is achieved with either the 50 or 60 Hz filter selected.

(3) Rated working voltage is the maximum continuous voltage that can be applied at the input terminal, including the input signal and the value that floats above ground potential (for example, 10V DC input signal and 20V DC potential above ground).

(4) For proper operation, both the plus and minus input terminals must be within $\pm 10V$ DC of analog common.

(5) Includes offset, gain, nonlinearity, and repeatability error terms.

(6) Repeatability is the ability of the input module to register the same reading in successive measurements for the same input signal.

(7) Damage may occur to the input circuit if this value is exceeded.

Response Speed - 1769-IF4I

Filter Frequency	Channel Update
28.5 Hz	108 ms
50 Hz	62 ms
60 Hz	52 ms
300 Hz	12 ms
360 Hz	10 ms

Certifications - 1769-IF4I

Certification ⁽¹⁾	1769-IF4I
c-UL	C-UL certified (under CSA C22.2 No. 142) UL 508 listed Class I, Division 2 Group A,B,C,D Hazardous Locations (UL 1604, C-UL under CSA C22.2 No. 213)
CE	CE compliant for all applicable directives

⁽¹⁾ When marked. See the Product Certification link at <http://www.ab.com> for Declarations of Conformity, Certificates, and other certification details.

1769-IF4XOF2

Compact combination input/output analog module

1769-IF4XOF2 Outputs

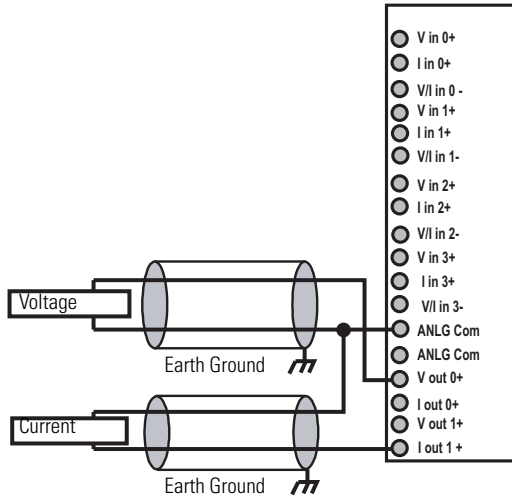

1769-IF4XOF2 Differential Inputs

Belden 8761 Cable (or equivalent)

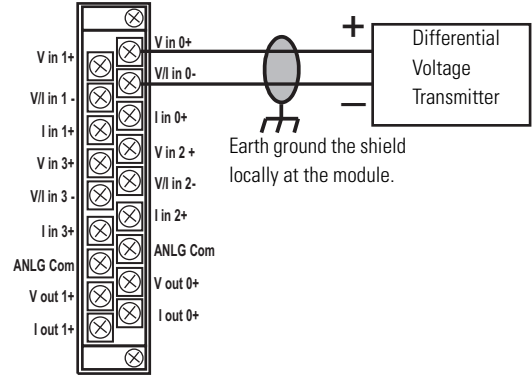

1769-IF4XOF2 Single-ended Sensor/Transmitter Inputs

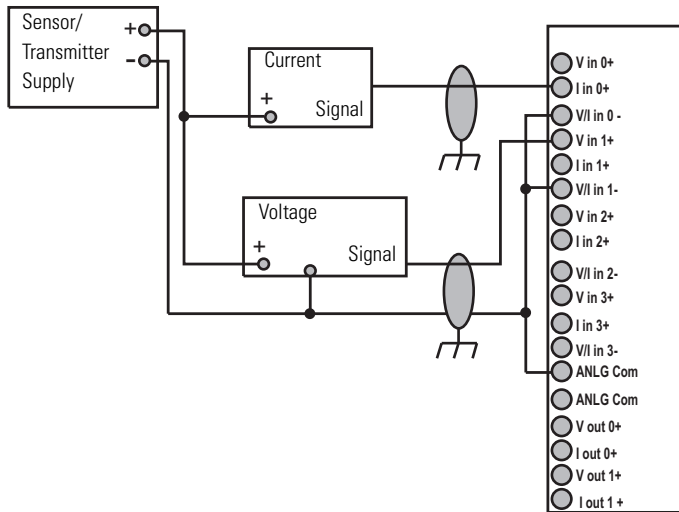

The sensor power supply must be rated Class 2.

1769-IF4XOF2 Mixed Transmitter Inputs

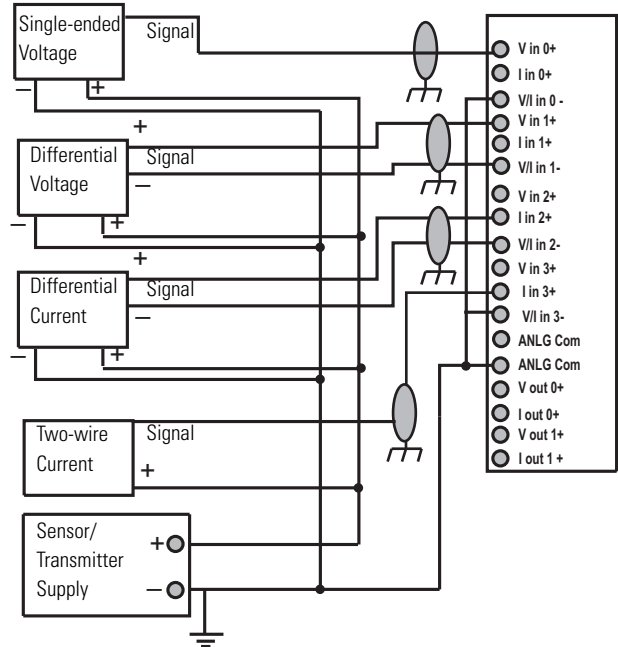

Technical Specifications - 1769-IF4XOF2

Attribute	1769-IF4XOF2
Current draw @ 5.1V	120 mA
Current draw @ 24V	160 mA
Heat dissipation, max	3.03 W
Weight, approx.	290 g (0.64 lb)
Dimensions (HxWxD), approx.	118 x 35 x 87 mm (4.65 x 1.38 x 3.43 in.) Height with mounting tabs 138 mm (5.43 in.)
Slot width	1
Module location	DIN rail or panel mount
Power supply	1769-PA2, 1769-PB2, 1769-PA4, 1769-PB4
Power supply distance rating	8 modules
Terminal screw torque	0.68 N•m (6 lb•in)
Retaining screw torque	0.46 N•m (4.1 lb•in)
Wire size	(22...14 AWG) solid (22...16 AWG) stranded
Wire type	Cu-90 °C (194 °F)
Replacement terminal block	1769-RTBN18 (1 per kit)
Replacement door label	1769-RL2 series B (2 per kit)
Replacement door	1769-RD (2 per kit)
Vendor ID code	1
Product type code	10
Product code	33
Enclosure type rating	None (open-style)

1769-IF4XOF2 Input Specifications

Attribute	1769-IF4XOF2
Inputs	4 differential or single-ended
Input range	0...10V 0...20 mA
Full scale range ⁽¹⁾	0...10.5V 0...21 mA
Converter type	Successive approximation
Resolution ⁽²⁾	8 bits plus sign
Response speed per channel	5 ms
Rated working voltage ⁽³⁾	30V AC/30V DC
Common mode voltage range ⁽⁴⁾	10V DC max per channel
Common mode rejection	> 60 dB @ 50 and 60 Hz with the 10 Hz filter selected
Input impedance	Current: 150 Ω Voltage: 150 kΩ
Accuracy ⁽⁵⁾	Current: ±0.6% full scale @ 25 °C (77 °F) Voltage: ±0.7% full scale @ 25 °C (77 °F)

1769-IF4XOF2 Input Specifications

Attribute	1769-IF4XOF2
Overall accuracy	Current: $\pm 0.8\%$ full scale @ 0...60 °C (32...140 °F) Voltage: $\pm 0.9\%$ full scale @ 0...60 °C (32...140 °F)
Accuracy drift with temperature	Current: $\pm 0.006\%$ per °C Voltage: $\pm 0.006\%$ per °C
Nonlinearity	$\pm 0.4\%$
Repeatability ⁽⁶⁾	$\pm 0.4\%$
Overload at input terminals, max ⁽⁷⁾	Current: ± 32 mA continuous, ± 5 V DC Voltage: ± 20 V DC continuous, 0.1 mA
Isolation voltage	500V AC or 710V DC for 1 minute (qualification test), group to bus 30V AC/30V DC working voltage (IEC Class 2 reinforced insulation)

⁽¹⁾ The over- or under-range flag will come on when the normal operating range (over/under) is exceeded. The module will continue to convert the analog input up to the maximum full scale range. The flag automatically resets when within the normal operating range.

⁽²⁾ Resolution is dependent upon your filter selection. The maximum resolution is achieved with either the 50 or 60 Hz filter selected.

⁽³⁾ Rated working voltage is the maximum continuous voltage that can be applied at the input terminal, including the input signal and the value that floats above ground potential (for example, 10V DC input signal and 20V DC potential above ground).

⁽⁴⁾ For proper operation, both the plus and minus input terminals must be within ± 10 V DC of analog common.

⁽⁵⁾ Includes offset, gain, nonlinearity, and repeatability error terms.

⁽⁶⁾ Repeatability is the ability of the input module to register the same reading in successive measurements for the same input signal.

⁽⁷⁾ Damage may occur to the input circuit if this value is exceeded.

1769-IF4XOF2 Output Specifications

Attribute	1769-IF4XOF2
Outputs	2 single-ended
Output range	0...10V 0...20 mA
Full scale range ⁽¹⁾	0...10.5V 0...21 mA
Converter type	Resistor string
Resolution	8 bits plus sign
Response speed per channel	0.3 ms for rated resistance and rated inductance 3.0 ms for rated capacitance
Current load on voltage output, max	10 mA
Resistive load on current output	0...300 Ω (includes wire resistance)
Load range on voltage output	> 1 k Ω
Inductive load, max	Current: 0.1 mH Voltage: 1 μ F
Accuracy ⁽²⁾	Current: $\pm 0.5\%$ full scale @ 25 °C (77 °F) Voltage: $\pm 0.5\%$ full scale @ 25 °C (77 °F)

1769-IF4XOF2 Output Specifications

Attribute	1769-IF4XOF2
Overall accuracy	Current: $\pm 1.0\%$ full scale @ 0...60 °C (32...140 °F) Voltage: $\pm 0.6\%$ full scale @ 0...60 °C (32...140 °F)
Accuracy drift with temperature	Current: $\pm 0.01\%$ per °C Voltage: $\pm 0.01\%$ per °C
Output ripple ⁽³⁾	$\pm 0.05\%$ @ 0...50 kHz
Nonlinearity	$\pm 0.4\%$
Repeatability ⁽⁴⁾	$\pm 0.05\%$
Output impedance	10 k Ω
Open and short-circuit protection	Yes
Short-circuit, max	40 mA
Open circuit, max	15V
Output response at system powerup and power down	+2.0...-1.0V DC spike for < 6 ms
Isolation voltage	500V AC or 710V DC for 1 min (qualification test), output group to bus 30V AC/30V DC working voltage (IEC Class 2 reinforced insulation)

⁽¹⁾ The over- or under-range flag will come on when the normal operating range (over/under) is exceeded. The module will continue to convert the analog input up to the maximum full scale range. The flag automatically resets when within the normal operating range.

⁽²⁾ Includes offset, gain, nonlinearity, and repeatability error terms.

⁽³⁾ Output ripple is the amount a fixed output varies with time, assuming a constant load and temperature.

⁽⁴⁾ Repeatability is the ability of the input module to register the same reading in successive measurements for the same input signal.

Response Speed - 1769-IF4XOF2

Fixed Filter Frequency	Filter Cut-off Frequency	Step Response % Complete	Step Response Time
2.7 kHz	2.7 kHz	63 %	59 μ s
2.7 kHz	2.7 kHz	90 %	136 μ s (nom)

Certifications - 1769-IF4XOF2

Certification ⁽¹⁾	1769-IF4XOF2
c-UL	C-UL certified (under CSA C22.2 No. 142) UL 508 listed Class I, Division 2 Group A,B,C,D Hazardous Locations (UL 1604, C-UL under CSA C22.2 No. 213)
CE	CE compliant for all applicable directives
C-Tick	C-Tick compliant for all applicable directives

⁽¹⁾ When marked. See the Product Certification link at <http://www.ab.com> for Declarations of Conformity, Certificates, and other certification details.

1769-IF4FXOF2F

Compact combination fast input/output analog module

Simplified Input Circuit Diagram

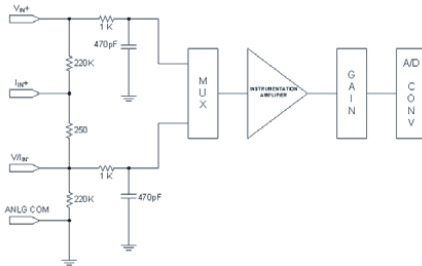

Simplified Output Circuit Diagram

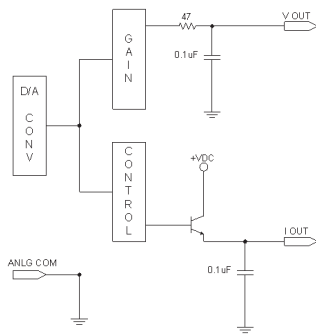

1769-IF4FXOF2F Differential Inputs

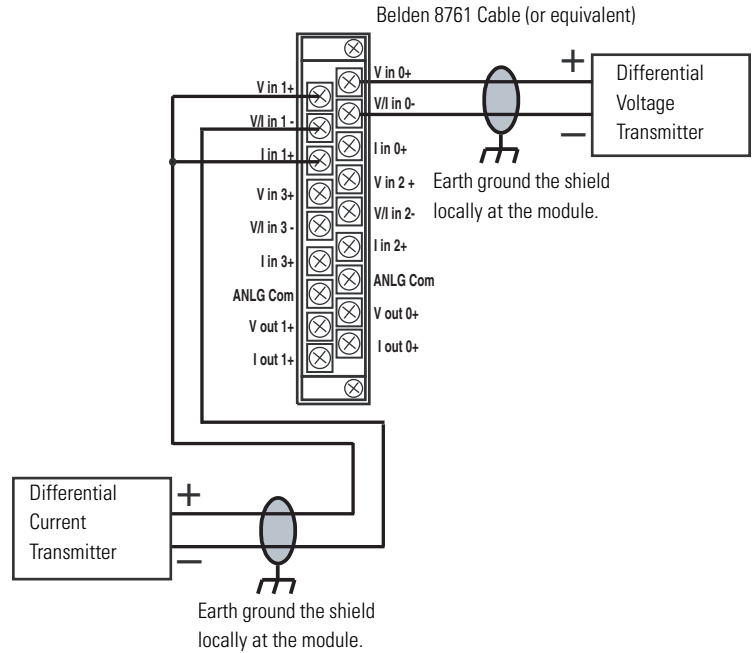

The sensor power supply must be rated Class 2.

1769-IF4FXOF2F Single-ended Sensor/Transmitter Inputs

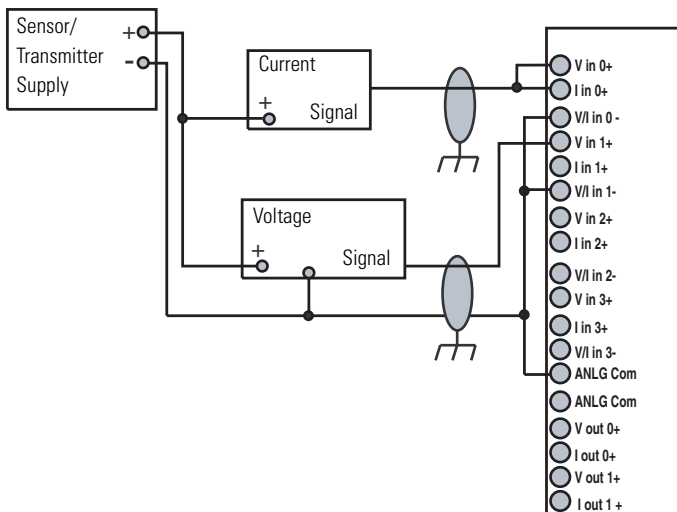

The sensor power supply must be rated Class 2.

1769-IF4FXOF2F Mixed Transmitter Inputs

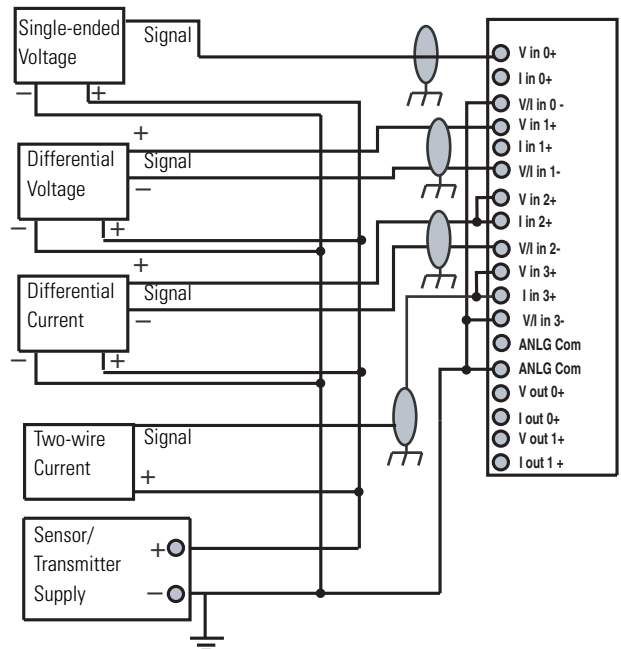

1769-IF4FXOF2F Outputs

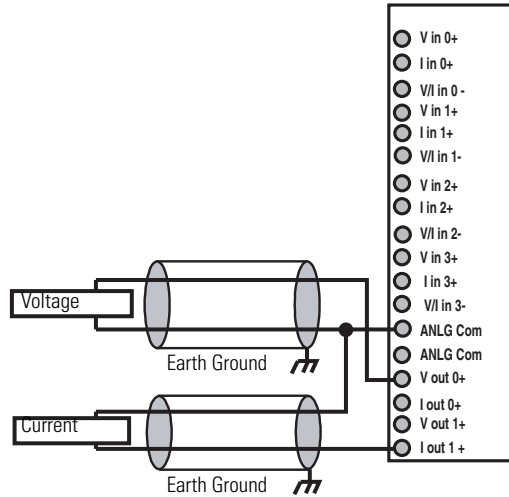

Technical Specifications - 1769-IF4FXOF2F

Attribute	1769-IF4FXOF2F
Current draw @ 5.1V	220 mA
Current draw @ 24V	120 mA
Heat dissipation, max	3.39 W
Weight, approx.	290 g (0.64 lb)
Dimensions (HxWxD), approx.	118 x 35 x 87 mm (4.65 x 1.38 x 3.43 in.) Height with mounting tabs 138 mm (5.43 in.)
Slot width	1
Module location	DIN rail or panel mount
Power supply	1769-PA2, 1769-PB2, 1769-PA4, 1769-PB4
Power supply distance rating	8 modules
Terminal screw torque	0.68 N•m (6 lb•in)
Retaining screw torque	0.46 N•m (4.1 lb•in)
Wire size	(22...14 AWG) solid (22...16 AWG) stranded
Wire type	Cu-90 °C (194 °F)
Replacement terminal block	1769-RTBN18 (1 per kit)
Replacement door label	1769-RL2 series B (2 per kit)
Replacement door	1769-RD (2 per kit)
Vendor ID code	1
Product type code	10
Product code	43
Input words	10
Output words	4
Configuration words	42
Enclosure type rating	None (open-style)

1769-IF4FXOF2F Input Specifications

Attribute	1769-IF4FXOF2F
Inputs	4 differential or single-ended
Input range	±10V 0...10V 0...5V 1...5V 0...20 mA 4...20 mA
Full scale range ⁽¹⁾	±10.5V -0.5...10.5V -0.5...5.25V 0.5...5.25V 0...21 mA 3.2...21 mA
Converter type	Successive approximation
Resolution ⁽²⁾	14 bits (unipolar) 14 bits plus sign (bipolar)
Rated working voltage ⁽³⁾	30V AC/30V DC
Common mode voltage range ⁽⁴⁾	±10V DC max per channel
Common mode rejection	> 70 dB @ 50 and 60 Hz with the 10 Hz filter selected
Input impedance	Current: 250 Ω Voltage: 220 kΩ
Accuracy ⁽⁵⁾	Current: ±0.2% full scale @ 25 °C (77 °F) Voltage: ±0.15% full scale @ 25 °C (77 °F)
Accuracy drift with temperature	Current: ±0.0045% per °C Voltage: ±0.003% per °C
Nonlinearity	±0.03%
Repeatability ⁽⁶⁾	±0.03%
Module error	Current: ±0.3% Voltage: ±0.2%
Overload at input terminals, max ⁽⁷⁾	Current: ±32 mA continuous, ±7.6V DC Voltage: ±30V DC continuous, 0.1 mA
Isolation voltage	500V AC or 710V DC for 1 minute (qualification test), group to bus 30V AC/30V DC working voltage (IEC Class 2 reinforced insulation)

⁽¹⁾ The over- or under-range flag will come on when the normal operating range (over/under) is exceeded. The module will continue to convert the analog input up to the maximum full scale range. The flag automatically resets when within the normal operating range.

⁽²⁾ Resolution is dependent upon your filter selection. The maximum resolution is achieved with either the 50 or 60 Hz filter selected.

⁽³⁾ Rated working voltage is the maximum continuous voltage that can be applied at the input terminal, including the input signal and the value that floats above ground potential (for example, 10V DC input signal and 20V DC potential above ground).

⁽⁴⁾ For proper operation, both the plus and minus input terminals must be within ±10V DC of analog common.

⁽⁵⁾ Includes offset, gain, nonlinearity, and repeatability error terms.

⁽⁶⁾ Repeatability is the ability of the input module to register the same reading in successive measurements for the same input signal.

⁽⁷⁾ Damage may occur to the input circuit if this value is exceeded.

1769-IF4FXOF2F Output Specifications

Attribute	1769-IF4FXOF2F
Outputs	2 single-ended
Output range	±10V 0...10V 0...5V 1...5V 0...20 mA 4...20 mA
Full scale range ⁽¹⁾	±10.5V -0.5...10.5V -0.5...5.25V 0.5...5.25V 0...21 mA 3.2...21 mA
Resolution	13 bits (unipolar) 13 bits plus sign (bipolar)
Conversion rate (all channels), max	1 ms
Step response to 63% ⁽²⁾	2.0 ms
Current load on voltage output, max	10 mA
Resistive load	Current: 0...500 Ω (includes wire resistance) Voltage: 1 kΩ or greater
Inductive load, max	Current: 0.1 mH Voltage: 1 μF
Field calibration	None required
Accuracy ⁽³⁾	±0.2% full scale @ 25 °C (77 °F)
Accuracy drift with temperature	Current: ±0.0058% per °C Voltage: ±0.0086% per °C
Output ripple ⁽⁴⁾	±0.05% @ 0...50 kHz
Nonlinearity	±0.05%
Repeatability ⁽⁵⁾	±0.05%
Module error	Current: ±0.4% Voltage: ±0.3%
Open and short-circuit protection	Yes
Short-circuit protection, max	50 mA
Output overvoltage protection	Yes
Rated working voltage ⁽⁶⁾	30V AC/30V DC
Isolation voltage	500V AC or 710V DC for 1 min (qualification test), output group to bus 30V AC/30V DC working voltage (IEC Class 2 reinforced insulation)

(1) The over- or under-range flag will come on when the normal operating range (over/under) is exceeded. The module will continue to convert the analog input up to the maximum full scale range. The flag automatically resets when within the normal operating range.

(2) Step response is the period of time between when the D/A converter was instructed to go from minimum to full range until the device is at 63% of full range.

(3) Includes offset, gain, nonlinearity, and repeatability error terms.

(4) Output ripple is the amount a fixed output varies with time, assuming a constant load and temperature.

(5) Repeatability is the ability of the input module to register the same reading in successive measurements for the same input signal.

(6) Rated working voltage is the maximum continuous voltage that can be applied at the input terminal, including the input signal and the value that floats above ground potential (for example, 10V DC input signal and 20V DC potential above ground).

Response Speed - 1769-IF4FXOF2F

Filter Frequency	Channel Step Response
5 Hz	802 ms
10 Hz	401 ms
50 Hz	81 ms
60 Hz	65 ms
100 Hz	42 ms
250 Hz	17 ms
500 Hz	10 ms
1000 Hz	5 ms

Certifications - 1769-IF4FXOF2F

Certification ⁽¹⁾	1769-IF4FXOF2F
c-UL	C-UL certified (under CSA C22.2 No. 142) UL 508 listed Class I, Division 2 Group A,B,C,D Hazardous Locations (UL 1604, C-UL under CSA C22.2 No. 213)
CE	CE compliant for all applicable directives

(1) When marked. See the Product Certification link at <http://www.ab.com> for Declarations of Conformity, Certificates, and other certification details.

1769-IF8

Compact voltage/current analog input module

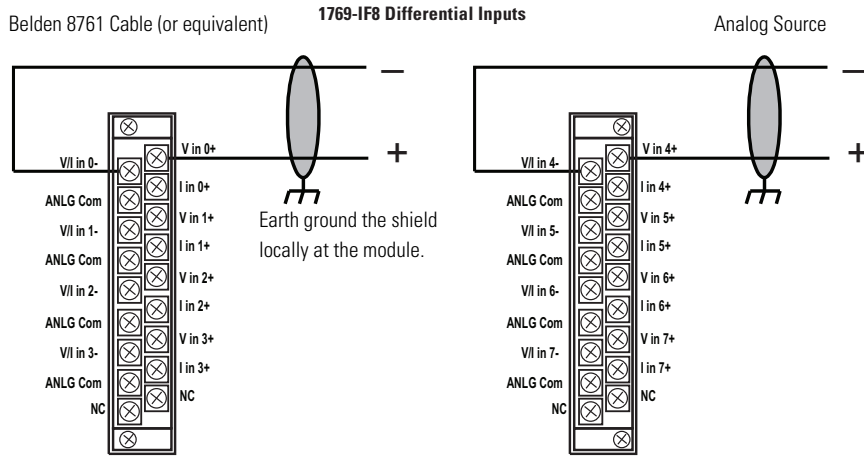

Earth ground the shield locally at the module.

1769-IF8 Single-ended Sensor/Transmitter Inputs

The sensor power supply must be rated Class 2.

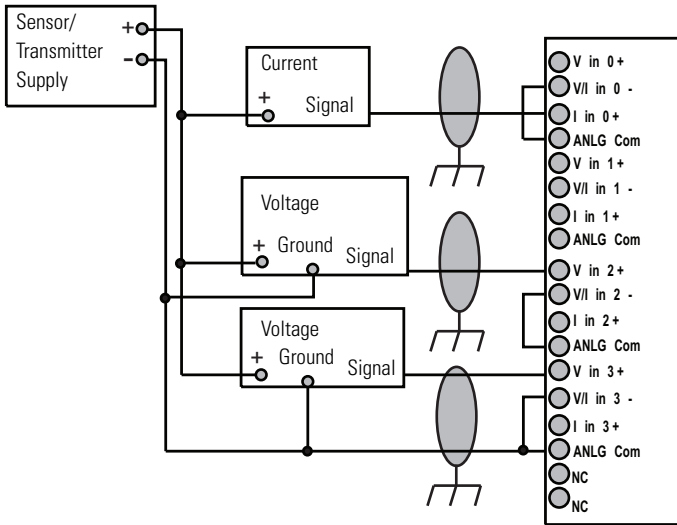

Wiring for channels 4...7 are identical.

1769-IF8 Mixed Transmitter Inputs

The sensor power supply must be rated Class 2.

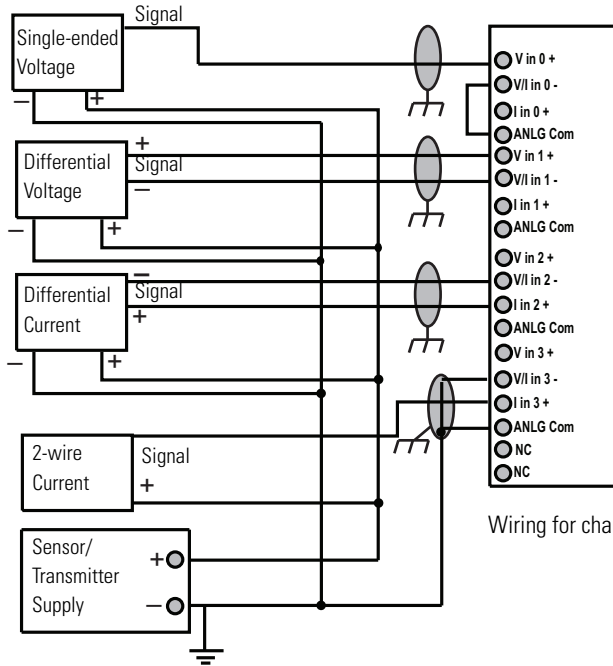

Wiring for channels 4-7 are identical.

Technical Specifications - 1769-IF8

Attribute	1769-IF8
Inputs	8 differential or single-ended
Input range	±10V 0...10V 0...5V 1...5V 0...20 mA 4...20 mA
Full scale range ⁽¹⁾	±10.5V -0.5...10.5V -0.5...5.25V 0.5...5.25V 0...21 mA 3.2...21 mA
Current draw @ 5.1V	120 mA
Current draw @ 24V	70 mA
Converter type	Delta Sigma
Heat dissipation, max	3.24 W
Resolution ⁽²⁾	16 bits (unipolar) 15 bits plus sign (bipolar)
Rated working voltage ⁽³⁾	30V AC/30V DC
Common mode voltage range ⁽⁴⁾	±10V DC max per channel
Common mode rejection	> 60 dB @ 50 and 60 Hz with the 10 Hz filter selected
Normal mode rejection ratio	-50 dB @ 50 and 60 Hz with the 10 Hz filter selected

Technical Specifications - 1769-IF8

Attribute	1769-IF8
Input impedance	Voltage: 220 k Ω Current: 250 Ω
Accuracy ⁽⁵⁾	Voltage: $\pm 0.2\%$ full scale @ 25 °C (77 °F) Current: $\pm 0.35\%$ full scale @ 25 °C (77 °F)
Accuracy drift with temperature	Voltage: $\pm 0.003\%$ per °C Current: $\pm 0.0045\%$ per °C
Nonlinearity	$\pm 0.03\%$
Repeatability ⁽⁶⁾	$\pm 0.03\%$
Module error	Voltage: $\pm 0.3\%$ Current: $\pm 0.5\%$
Overload at input terminals, max ⁽⁷⁾	Voltage: $\pm 30\text{V}$ DC continuous, 0.1 mA Current: ± 32 mA continuous, $\pm 7.6\text{V}$ DC
Isolation voltage	500V AC or 710V DC for 1 minute (qualification test), group to bus 30V AC/30V DC working voltage (IEC Class 2 reinforced insulation)
Weight, approx.	450 g (0.99 lb)
Dimensions (HxWxD), approx.	118 x 52.5 x 87 mm (4.65 x 2.07 x 3.43 in.) Height with mounting tabs 138 mm (5.43 in.)
Slot width	1.5
Module location	DIN rail or panel mount
Power supply	1769-PA2, 1769-PB2, 1769-PA4, 1769-PB4
Power supply distance rating	8 modules
Terminal screw torque	0.68 N•m (6 lb•in)
Retaining screw torque	0.46 N•m (4.1 lb•in)
Wire size	(22...14 AWG) solid (22...16 AWG) stranded
Wire type	Cu-90 °C (194 °F)
Replacement terminal block	1769-RTBN18 (1 per kit)
Replacement door label	1769-RL2 series B (2 per kit)
Replacement door	1769-RD (2 per kit)
Vendor ID code	1
Product type code	10
Product code	38
Enclosure type rating	None (open-style)

(1) The over- or under-range flag will come on when the normal operating range (over/under) is exceeded. The module will continue to convert the analog input up to the maximum full scale range. The flag automatically resets when within the normal operating range.

(2) Resolution is dependent upon your filter selection. The maximum resolution is achieved with either the 50 or 60 Hz filter selected.

(3) Rated working voltage is the maximum continuous voltage that can be applied at the input terminal, including the input signal and the value that floats above ground potential (for example, 10V DC input signal and 20V DC potential above ground).

(4) For proper operation, both the plus and minus input terminals must be within $\pm 10\text{V}$ DC of analog common.

(5) Includes offset, gain, nonlinearity, and repeatability error terms.

(6) Repeatability is the ability of the input module to register the same reading in successive measurements for the same input signal.

(7) Damage may occur to the input circuit if this value is exceeded.

Response Speed - 1769-IF8

Filter Frequency	Cut-off Frequency	Step Response	Channel Update
50 Hz	13.1 Hz	60 ms	22 ms
60 Hz	15.7 Hz	50 ms	19 ms
250 Hz	65.5 Hz	12 ms	6 ms
500 Hz	131 Hz	6 ms	4 ms

Certifications - 1769-IF8

Certification ⁽¹⁾	1769-IF8
c-UL	C-UL certified (under CSA C22.2 No. 142) UL 508 listed Class I, Division 2 Group A,B,C,D Hazardous Locations (UL 1604, C-UL under CSA C22.2 No. 213)
CE	CE compliant for all applicable directives

⁽¹⁾ When marked. See the Product Certification link at <http://www.ab.com> for Declarations of Conformity, Certificates, and other certification details.

1769-IF16C

Compact current analog input module

Simplified Input Circuit Diagram

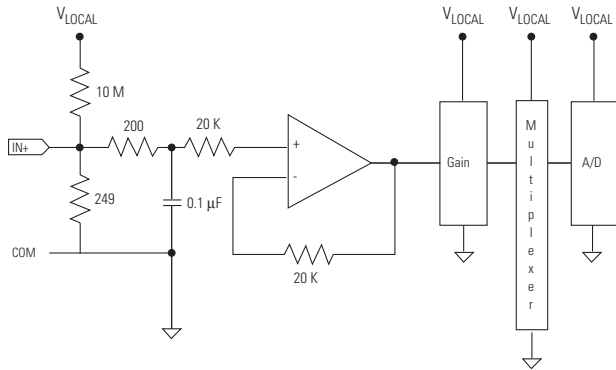

1769-IF16C Sensor/Transmitter Inputs

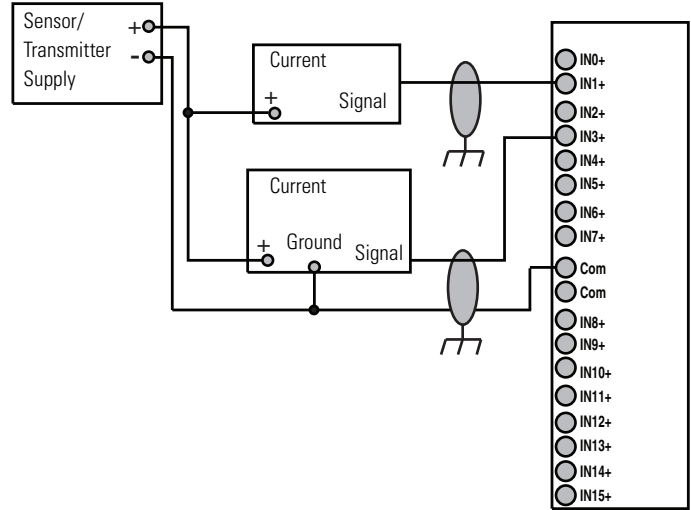

The sensor power supply must be rated Class 2.

Technical Specifications - 1769-IF16C

Attribute	1769-IF16C
Inputs	16 single-ended
Input range	0...20 mA 4...20 mA
Full scale range ⁽¹⁾	0...21 mA 3.2...21 mA
Current draw @ 5.1V	190 mA
Current draw @ 24V	70 mA
Heat dissipation, max	4.0 W
Converter type	Sigma Delta
Resolution ⁽²⁾	16 bits (unipolar) 15 bits plus sign (bipolar)
Rated working voltage ⁽³⁾	30V AC/30V DC
Common mode voltage range ⁽⁴⁾	±10V DC max per channel
Common mode rejection	> 60 dB @ 50 and 60 Hz with the 16 Hz filter selected
Input impedance	249 Ω
Accuracy ⁽⁵⁾	±0.5% full scale @ 25 °C (77 °F)
Accuracy drift with temperature	±0.0045% per °C
Nonlinearity	±0.03%
Repeatability ⁽⁶⁾	±0.03%
Module error	1.25%
Overload at input terminals, max ⁽⁷⁾	±28 mA continuous, ±7.6V DC

Technical Specifications - 1769-IF16C

Attribute	1769-IF16C
Isolation voltage	500V AC or 710V DC for 1 minute (qualification test), group to bus 30V AC/30V DC working voltage (IEC Class 2 reinforced insulation)
Weight, approx.	281 g (0.62 lb)
Dimensions (HxWxD), approx.	118 x 35 x 87 mm (4.65 x 1.38 x 3.43 in.) Height with mounting tabs 138 mm (5.43 in.)
Slot width	1
Module location	DIN rail or panel mount
Power supply	1769-PA2, 1769-PB2, 1769-PA4, 1769-PB4
Power supply distance rating	8 modules
Terminal screw torque	0.68 N•m (6 lb•in)
Retaining screw torque	0.46 N•m (4.1 lb•in)
Wire size	(22...14 AWG) solid (22...16 AWG) stranded
Wire type	Cu-90 °C (194 °F)
Replacement terminal block	1769-RTBN18 (1 per kit)
Replacement door label	1769-RL2 series B (2 per kit)
Replacement door	1769-RD (2 per kit)
Vendor ID code	1
Product type code	10
Product code	47
Input words	22
Output words	2
Configuration words	98
Enclosure type rating	None (open-style)

⁽¹⁾ The over- or under-range flag will come on when the normal operating range (over/under) is exceeded. The module will continue to convert the analog input up to the maximum full scale range. The flag automatically resets when within the normal operating range.

⁽²⁾ Resolution is dependent upon your filter selection. The maximum resolution is achieved with either the 50 or 60 Hz filter selected.

⁽³⁾ Rated working voltage is the maximum continuous voltage that can be applied at the input terminal, including the input signal and the value that floats above ground potential (for example, 10V DC input signal and 20V DC potential above ground).

⁽⁴⁾ For proper operation, both the plus and minus input terminals must be within $\pm 10V$ DC of analog common.

⁽⁵⁾ Includes offset, gain, nonlinearity, and repeatability error terms.

⁽⁶⁾ Repeatability is the ability of the input module to register the same reading in successive measurements for the same input signal.

⁽⁷⁾ Damage may occur to the input circuit if this value is exceeded.

Response Speed - 1769-IF16C

Filter Frequency	Step Response	Update per Input Pari	Update per Module
16 Hz	1550 ms	200 ms	1600 ms
50 Hz	500 ms	70 ms	560 ms
60 Hz	420 ms	60 ms	480 ms
315 Hz	90 ms	15 ms	120 ms
1365 Hz	35 ms	5 ms	40 ms

Certifications - 1769-IF16C

Certification ⁽¹⁾	1769-IF16C
c-UL	C-UL certified (under CSA C22.2 No. 142) UL 508 listed Class I, Division 2 Group A,B,C,D Hazardous Locations (UL 1604, C-UL under CSA C22.2 No. 213)
CE	CE compliant for all applicable directives

⁽¹⁾ When marked. See the Product Certification link at <http://www.ab.com> for Declarations of Conformity, Certificates, and other certification details.

1769-IF16V

Compact voltage analog input module

Simplified Input Circuit Diagram

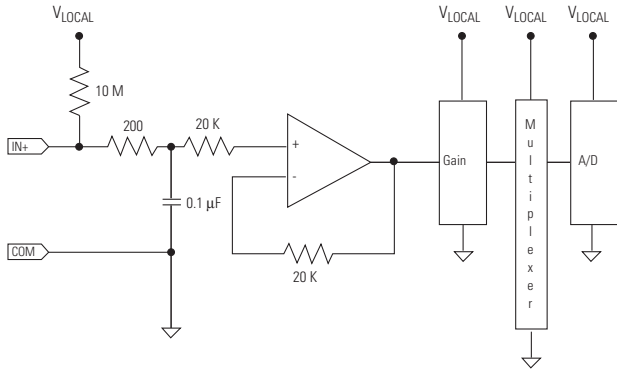

1769-IF16V Sensor/Transmitter Inputs

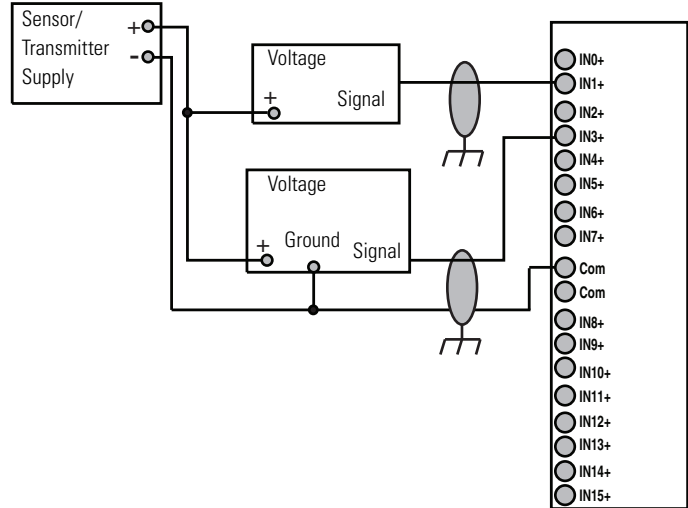

The sensor power supply must be rated Class 2.

Technical Specifications - 1769-IF16V

Attribute	1769-IF16V
Inputs	16 single-ended
Input range	±10V 0...10V 0...5V 1...5V
Full scale range ⁽¹⁾	±10.5V -0.5...10.5V -0.5...5.25V 0.5...5.25V
Current draw @ 5.1V	190 mA
Current draw @ 24V	70 mA
Heat dissipation, max	2.4 W
Converter type	Sigma Delta
Resolution ⁽²⁾	16 bits (unipolar) 15 bits plus sign (bipolar)
Rated working voltage ⁽³⁾	30V AC/30V DC
Common mode voltage range ⁽⁴⁾	±10V DC max per channel
Common mode rejection	> 60 dB @ 50 and 60 Hz with the 16 Hz filter selected
Input impedance	> 1MΩ
Accuracy ⁽⁵⁾	±0.35% full scale @ 25 °C (77 °F)
Accuracy drift with temperature	±0.03% per °C
Nonlinearity	±0.03%
Repeatability ⁽⁶⁾	±0.06%
Module error	1.0%

Technical Specifications - 1769-IF16V

Attribute	1769-IF16V
Overload at input terminals, max ⁽⁷⁾	±30 mA continuous, ±7.6V DC
Isolation voltage	500V AC or 710V DC for 1 minute (qualification test), group to bus 30V AC/30V DC working voltage (IEC Class 2 reinforced insulation)
Weight, approx.	281 g (0.62 lb)
Dimensions (HxWxD), approx.	118 x 35 x 87 mm (4.65 x 1.38 x 3.43 in.) Height with mounting tabs 138 mm (5.43 in.)
Slot width	1
Module location	DIN rail or panel mount
Power supply	1769-PA2, 1769-PB2, 1769-PA4, 1769-PB4
Power supply distance rating	8 modules
Terminal screw torque	0.68 N•m (6 lb•in)
Retaining screw torque	0.46 N•m (4.1 lb•in)
Wire size	(22...14 AWG) solid (22...16 AWG) stranded
Wire type	Cu-90 °C (194 °F)
Replacement terminal block	1769-RTBN18 (1 per kit)
Replacement door label	1769-RL2 series B (2 per kit)
Replacement door	1769-RD (2 per kit)
Vendor ID code	1
Product type code	10
Product code	46
Input words	22
Output words	2
Configuration words	98
Enclosure type rating	None (open-style)

(1) The over- or under-range flag will come on when the normal operating range (over/under) is exceeded. The module will continue to convert the analog input up to the maximum full scale range. The flag automatically resets when within the normal operating range.

(2) Resolution is dependent upon your filter selection. The maximum resolution is achieved with either the 50 or 60 Hz filter selected.

(3) Rated working voltage is the maximum continuous voltage that can be applied at the input terminal, including the input signal and the value that floats above ground potential (for example, 10V DC input signal and 20V DC potential above ground).

(4) For proper operation, both the plus and minus input terminals must be within ±10V DC of analog common.

(5) Includes offset, gain, nonlinearity, and repeatability error terms.

(6) Repeatability is the ability of the input module to register the same reading in successive measurements for the same input signal.

(7) Damage may occur to the input circuit if this value is exceeded.

Response Speed - 1769-IF16V

Filter Frequency	Step Response	Update per Input Pari	Update per Module
16 Hz	1550 ms	200 ms	1600 ms
50 Hz	500 ms	70 ms	560 ms
60 Hz	420 ms	60 ms	480 ms
315 Hz	90 ms	15 ms	120 ms
1365 Hz	35 ms	5 ms	40 ms

Certifications - 1769-IF16V

Certification ⁽¹⁾	1769-IF16V
c-UL	C-UL certified (under CSA C22.2 No. 142) UL 508 listed Class I, Division 2 Group A,B,C,D Hazardous Locations (UL 1604, C-UL under CSA C22.2 No. 213)
CE	CE compliant for all applicable directives

⁽¹⁾ When marked. See the Product Certification link at <http://www.ab.com> for Declarations of Conformity, Certificates, and other certification details.

1769-IG16

Compact TTL input module

Simplified Input Circuit Diagram

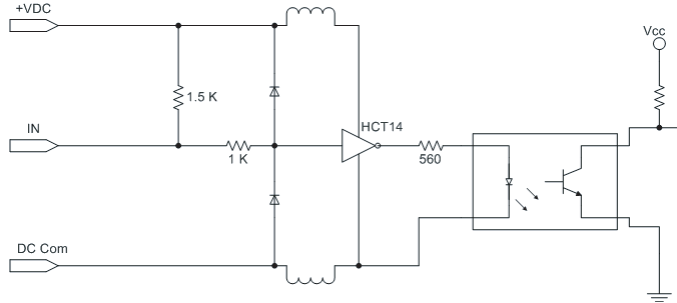

- Use Belden 8761, or equivalent, shielded wire.
- Do not connect more than 2 wires to any single terminal.
- DC power cable and I/O cables should not exceed 10 m (30 ft).
- The capacitors shown above must be 0.01µF and rated for 2000V min.
- User power supply must be rated Class 2 with a 5V DC range of 4.5...5.5V DC.

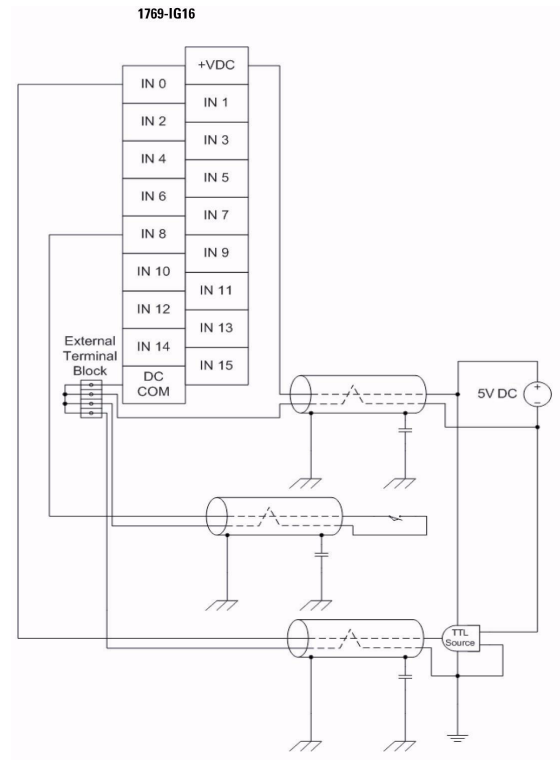

Low to True Format - 1769-IG16

- -0.2...0.8V = Input guaranteed to be in on-state
- 0.8...2.0V = Input state not guaranteed
- 2.0...5.5V = Input guaranteed to be in off-state

Technical Specifications - 1769-IG16

Attribute	1769-IG16
Inputs	16
Voltage category	5V DC TTL source (Low=True) ⁽¹⁾
Operating voltage range	4.5...5.5V DC 50 mV peak-to-peak ripple max
Input delay, on	20 ms
Digital filter, off to on	0 s, 100 µs, 500 µs, 1 ms, 2 ms, 4 ms, 8 ms
Digital filter, on to off	0 s, 100 µs, 500 µs, 1 ms, 2 ms, 4 ms, 8 ms
Current draw @ 5.1V	120 mA
Heat dissipation, max	1.6 W
Off-state voltage, typical	2.0...5.5V DC
Off-state current, max	4.1 mA

Technical Specifications - 1769-IG16

Attribute	1769-IG16
On-state voltage, typical	-0.2...0.8V DC
On-state current, nom	3.7 mA @ 5V DC
Isolation voltage	Verified by one of the following dielectric tests: 1200V AC for 2 s or 1697V DC for 2 s, input point to bus 75V DC working voltage (IEC Class 2 reinforced insulation)
Weight, approx.	250 g (0.55 lb)
Dimensions (HxWxD), approx.	118 x 35 x 87 mm (4.65 x 1.38 x 3.43 in.) Height with mounting tabs 138 mm (5.43 in.)
Slot width	1
Module location	DIN rail or panel mount
Power supply	1769-PA2, 1769-PB2, 1769-PA4, 1769-PB4
Power supply distance rating	8 modules
Terminal screw torque	0.68 N•m (6 lb•in)
Retaining screw torque	0.46 N•m (4.1 lb•in)
Wire size	(22...14 AWG) solid (22...16 AWG) stranded
Wire type	Cu-90 °C (194 °F)
IEC input compatibility	No
Vendor ID code	1
Product type code	7
Product code	77
Input words	1
Output words	0
Configuration words	4
Enclosure type rating	None (open-style)

⁽¹⁾ TTL inputs are inverted (-0.2 to +0.8 = low voltage = True = On.) Use a NOT instruction in your program to convert to traditional True = High logic.

Certifications - 1769-IG16

Certification ⁽¹⁾	1769-IG16
c-UL	C-UL certified (under CSA C22.2 No. 142) UL 508 listed Class I, Division 2 Group A,B,C,D Hazardous Locations (UL 1604, C-UL under CSA C22.2 No. 213)
CE	CE compliant for all applicable directives

⁽¹⁾ When marked. See the Product Certification link at <http://www.ab.com> for Declarations of Conformity, Certificates, and other certification details.

1769-IM12

Compact 240V AC input module

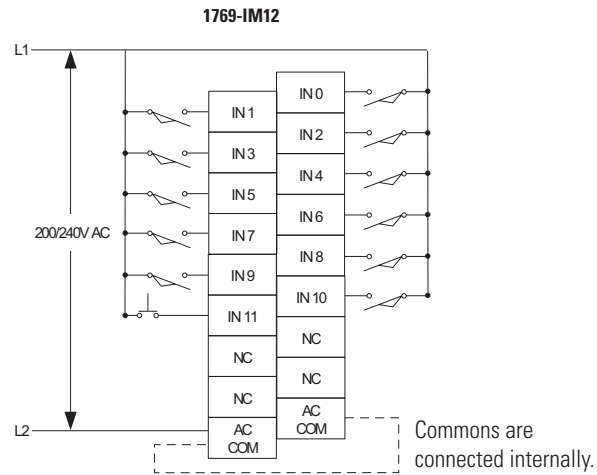

Do not use the NC terminals as a connection.

Technical Specifications - 1769-IM12

Attribute	1769-IM12
Inputs	12 (12 points/group, internally connected commons)
Voltage category	200/240V AC
Operating voltage range	159...265V AC, 47...63 Hz
Input delay, on	20 ms
Input delay, off	20 ms
Current draw @ 5.1V	100 mA
Heat dissipation, max	3.65 W
Off-state voltage, max	40V AC
Off-state current, max	2.5 mA
On-state voltage, min	159V AC
On-state current, min	5 mA @ 74V AC
On-state current, max	12 mA @ 120V AC
Inrush current, max ⁽¹⁾	250 mA
Input impedance, max	27 kΩ @ 50 Hz 23 kΩ @ 60 Hz
Isolation voltage	Verified by one of the following dielectric tests: 1836V AC for 1 s or 2596V DC for 1 s, input point to bus 132V AC working voltage (IEC Class 2 reinforced insulation)
Weight, approx.	300 g (0.61 lb)
Dimensions (HxWxD), approx.	118 x 35 x 87 mm (4.65 x 1.38 x 3.43 in.) Height with mounting tabs 138 mm (5.43 in.)
Slot width	1
Module location	DIN rail or panel mount
Power supply	1769-PA2, 1769-PB2, 1769-PA4, 1769-PB4

Technical Specifications - 1769-IM12

Attribute	1769-IM12
Power supply distance rating	8 modules
Terminal screw torque	0.68 N•m (6 lb•in)
Retaining screw torque	0.46 N•m (4.1 lb•in)
Wire size	(22...14 AWG) solid (22...16 AWG) stranded
Wire type	Cu-90 °C (194 °F)
IEC input compatibility	Type 1+
Replacement terminal block	1769-RTBN18 (1 per kit)
Replacement door label	1769-RL1 (2 per kit)
Replacement door	1769-RD (2 per kit)
Vendor ID code	1
Product type code	7
Product code	83
Enclosure type rating	None (open-style)

⁽¹⁾ A current limiting resistor can be used to limit inrush current; however, the operating characteristics of the AC input circuit will be affected. If a 6.8 kΩ (2.5W minimum) resistor is placed in series with the input, the inrush current is reduced to 35 mA. In this configuration the minimum on-state voltage increases to 92V AC. Before adding the resistor in a hazardous environment, be sure to consider the operating temperature of the resistor and the temperature limits of the environment. The operating temperature of the resistor must remain below the temperature limit of the environment.

Certifications - 1769-IM12

Certification ⁽¹⁾	1769-IM12
c-UL	C-UL certified (under CSA C22.2 No. 142) UL 508 listed Class I, Division 2 Group A,B,C,D Hazardous Locations (UL 1604, C-UL under CSA C22.2 No. 213)
CE	CE compliant for all applicable directives

⁽¹⁾ When marked. See the Product Certification link at <http://www.ab.com> for Declarations of Conformity, Certificates, and other certification details.

1769-IQ16

Compact 24V DC sink/source input module

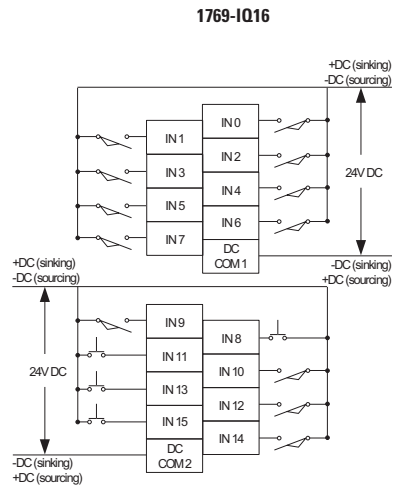

Technical Specifications - 1769-IQ16

Attribute	1769-IQ16
Inputs	16 (8 points/group)
Voltage category	24V DC sink/source
Operating voltage range	10...30V DC @ 30 °C (86 °F) 10...26.4V DC @ 60 °C (140 °F)
Input delay, on	8 ms
Input delay, off	8 ms
Current draw @ 5.1V	115 mA
Heat dissipation, max	3.55 W
Off-state voltage, max	5V DC
Off-state current, max	1.5 mA
On-state voltage, min	10V DC
On-state current, min	2 mA
Inrush current, max	250 mA
Input impedance, nom	3 k Ω
Isolation voltage	Verified by one of the following dielectric tests: 1200V AC for 1 s or 1697V DC for 1 s, input point to bus and group to group 75V DC working voltage (IEC Class 2 reinforced insulation)
Weight, approx.	270 g (0.60 lb)
Dimensions (HxWxD), approx.	118 x 35 x 87 mm (4.65 x 1.38 x 3.43 in.) Height with mounting tabs 138 mm (5.43 in.)
Slot width	1
Module location	DIN rail or panel mount
Power supply	1769-PA2, 1769-PB2, 1769-PA4, 1769-PB4
Power supply distance rating	8 modules
Terminal screw torque	0.68 N•m (6 lb•in)

Technical Specifications - 1769-IQ16

Attribute	1769-IQ16
Retaining screw torque	0.46 N•m (4.1 lb•in)
Wire size	(22...14 AWG) solid (22...16 AWG) stranded
Wire type	Cu-90 °C (194 °F)
IEC input compatibility	Type 1+
Replacement terminal block	1769-RTBN18 (1 per kit)
Replacement door label	1769-RL1 (2 per kit)
Replacement door	1769-RD (2 per kit)
Vendor ID code	1
Product type code	7
Product code	67
Enclosure type rating	None (open-style)

Certifications - 1769-IQ16

Certification ⁽¹⁾	1769-IQ16
c-UL	C-UL certified (under CSA C22.2 No. 142) UL 508 listed Class I, Division 2 Group A,B,C,D Hazardous Locations (UL 1604, C-UL under CSA C22.2 No. 213)
CE	CE compliant for all applicable directives

⁽¹⁾ When marked. See the Product Certification link at <http://www.ab.com> for Declarations of Conformity, Certificates, and other certification details.

1769-IQ16F

Compact 24V DC sink/source, high-speed input module

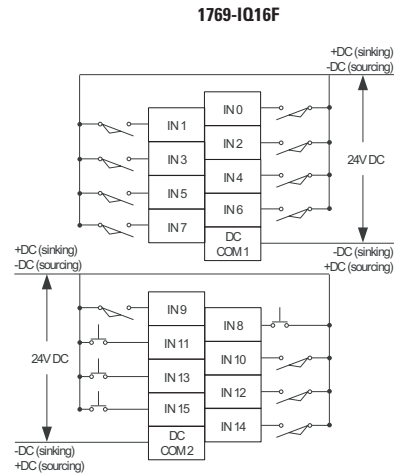

Technical Specifications - 1769-IQ16F

Attribute	1769-IQ16F
Inputs	16 (8 points/group)
Voltage category	24V DC sink/source
Operating voltage range	10...30V DC @ 30 °C (86 °F) 10...26.4V DC @ 60 °C (140 °F)
Digital filter, off to on	0 s, 100 μs, 500 μs, 1 ms, 2 ms
Digital filter, on to off	0 s, 100 μs, 500 μs, 1 ms, 2 ms
Input delay, off to on	100 μs, typical 300 μs, max
Input delay, on to off	250 μs, typical 1 ms, max
Current draw @ 5.1V	110 mA
Heat dissipation, max	3.55 W
Off-state voltage, max	5V DC
Off-state current, max	1.5 mA
On-state voltage, min	10V DC
On-state current, min	2 mA
Inrush current, max	250 mA
Input impedance, nom	3 kΩ
Isolation voltage	Verified by one of the following dielectric tests: 1200V AC for 1 s or 1697V DC for 1 s, input point to bus and group to group 75V DC working voltage (IEC Class 2 reinforced insulation)
Weight, approx.	270 g (0.60 lb)
Dimensions (HxWxD), approx.	118 x 35 x 87 mm (4.65 x 1.38 x 3.43 in.) Height with mounting tabs 138 mm (5.43 in.)
Slot width	1

Technical Specifications - 1769-IQ16F

Attribute	1769-IQ16F
Module location	DIN rail or panel mount
Power supply	1769-PA2, 1769-PB2, 1769-PA4, 1769-PB4
Power supply distance rating	8 modules
Terminal screw torque	0.68 N•m (6 lb•in)
Retaining screw torque	0.46 N•m (4.1 lb•in)
Wire size	(22...14 AWG) solid (22...16 AWG) stranded
Wire type	Cu-90 °C (194 °F)
IEC input compatibility	Type 1+
Replacement terminal block	1769-RTBN18 (1 per kit)
Replacement door label	1769-RL1 (2 per kit)
Replacement door	1769-RD (2 per kit)
Vendor ID code	1
Product type code	7
Product code	69
Enclosure type rating	None (open-style)

Certifications - 1769-IQ16F

Certification⁽¹⁾	1769-IQ16F
c-UL	C-UL certified (under CSA C22.2 No. 142) UL 508 listed Class I, Division 2 Group A,B,C,D Hazardous Locations (UL 1604, C-UL under CSA C22.2 No. 213)
CE	CE compliant for all applicable directives

⁽¹⁾ When marked. See the Product Certification link at <http://www.ab.com> for Declarations of Conformity, Certificates, and other certification details.

1769-IQ32

Compact 24V DC sink/source input module

1769-IQ32

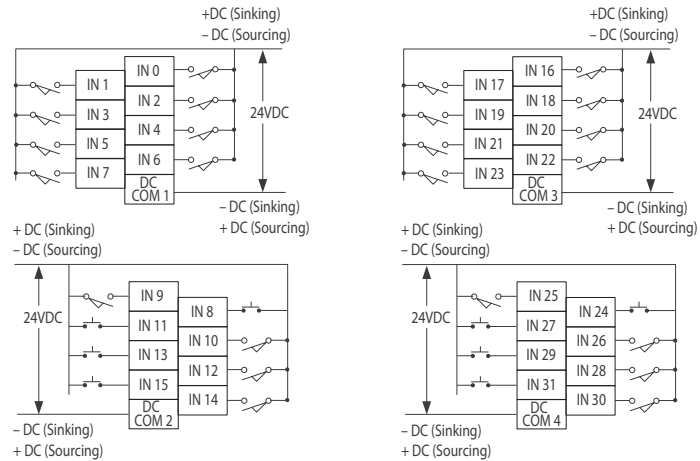

Technical Specifications - 1769-IQ32

Attribute	1769-IQ32
Inputs	32 (8 points/group)
Voltage category	24V DC sink/source
Operating voltage range	10...30V DC @ 30 °C (86 °F) 10...26.4V DC @ 60 °C (140 °F)
Input delay, on	8 ms
Input delay, off	8 ms
Current draw @ 5.1V	170 mA
Heat dissipation, max	4.6 W
Off-state voltage, max	5V DC
Off-state current, max	1.5 mA
On-state voltage, min	10V DC
On-state current, min	2 mA
Inrush current, max	250 mA
Input impedance, nominal	5.2 kΩ @ 24V DC 6.1 kΩ @ 30V DC
Isolation voltage	Verified by one of the following dielectric tests: 1200V AC for 1 s or 1697V DC for 1 s, input point to bus and group to group 75V DC working voltage (IEC Class 2 reinforced insulation)
Weight, approx.	440 g (0.97 lb)
Dimensions (HxWxD), approx.	118 x 52.5 x 87 mm (4.65 x 2.07 x 3.43 in.) Height with mounting tabs 138 mm (5.43 in.)
Slot width	1.5
Module location	DIN rail or panel mount
Power supply	1769-PA2, 1769-PB2, 1769-PA4, 1769-PB4

Technical Specifications - 1769-IQ32

Attribute	1769-IQ32
Power supply distance rating	8 modules
Terminal screw torque	0.68 N•m (6 lb•in)
Retaining screw torque	0.46 N•m (4.1 lb•in)
Wire size	(22...14 AWG) solid (22...16 AWG) stranded
Wire type	Cu-90 °C (194 °F)
IEC input compatibility	Type 1+
Replacement terminal block	1769-RTBN18 (1 per kit)
Replacement door label	1769-RL1 (2 per kit)
Replacement door	1769-RD (2 per kit)
Vendor ID code	1
Product type code	7
Product code	68
Enclosure type rating	None (open-style)

Certifications - 1769-IQ32

Certification⁽¹⁾	1769-IQ32
c-UL	C-UL certified (under CSA C22.2 No. 142) UL 508 listed Class I, Division 2 Group A,B,C,D Hazardous Locations (UL 1604, C-UL under CSA C22.2 No. 213)
CE	CE compliant for all applicable directives

⁽¹⁾ When marked. See the Product Certification link at <http://www.ab.com> for Declarations of Conformity, Certificates, and other certification details.

1769-IQ32T

Compact 24V DC sink/source, terminated input module

1769-IQ32T

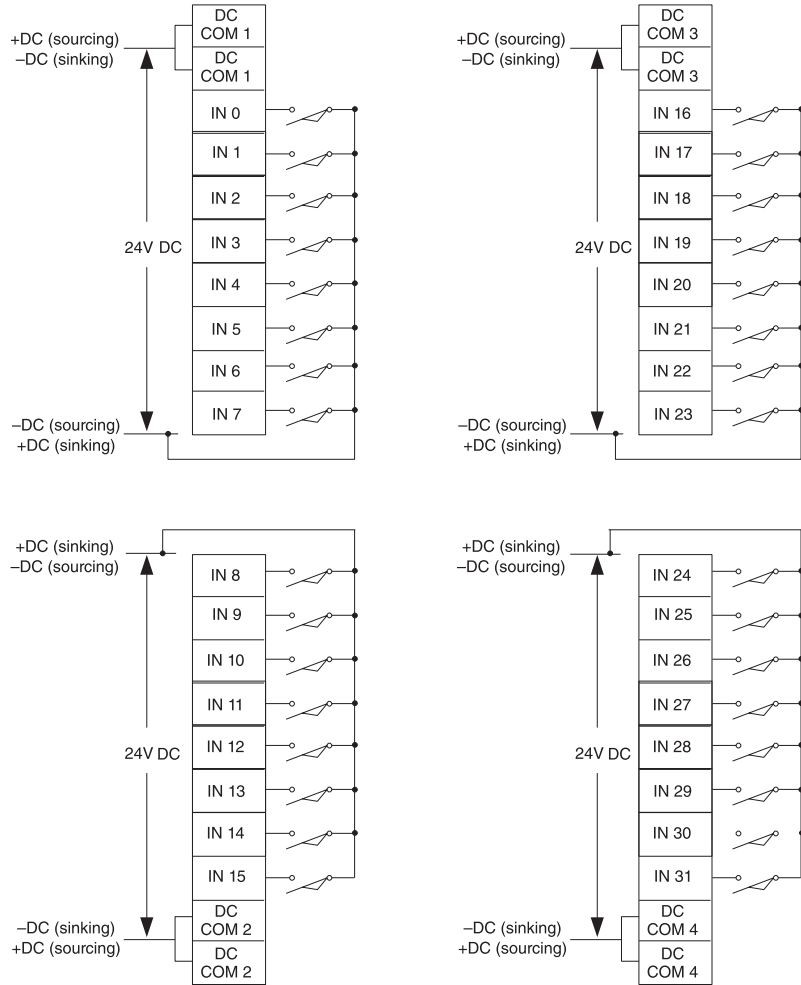

Technical Specifications - 1769-IQ32T

Attribute	1769-IQ32T
Inputs	32 terminated (8 points/group)
Voltage category	24V DC sink/source
Operating voltage range	20.4...26.4V DC @ 60 °C (140 °F)
Digital filter, off to on	0 s, 100 μs, 500 μs, 1 ms, 2 ms, 4 ms, 8 ms
Digital filter, on to off	0 s, 100 μs, 500 μs, 1 ms, 2 ms, 4 ms, 8 ms
Input delay, off to on	0.1 ms, typical 0.42 ms, max
Input delay, on to off	0.25 ms, typical 1.0 ms, max
Current draw @ 5.1V	170 mA
Heat dissipation, max	4.77 W
Off-state voltage, max	11V DC
Off-state current, max	1.7 mA

Technical Specifications - 1769-IQ32T

Attribute	1769-IQ32T
On-state voltage, min	19V DC
On-state current, min	2 mA
Inrush current, max	5 mA
Input impedance, nom	5.6 k Ω
Isolation voltage	Verified by one of the following dielectric tests: 1200V AC for 1 s or 1697V DC for 1 s, input point to bus and group to group 75V DC working voltage (IEC Class 2 reinforced insulation)
Weight, approx.	280 g (0.61 lb)
Dimensions (HxWxD), approx.	118 x 35 x 87 mm (4.65 x 1.38 x 3.43 in.) Height with mounting tabs 138 mm (5.43 in.)
Slot width	1
Module location	DIN rail or panel mount
Power supply	1769-PA2, 1769-PB2, 1769-PA4, 1769-PB4
Power supply distance rating	8 modules
Terminal screw torque	0.68 N•m (6 lb•in)
Retaining screw torque	0.46 N•m (4.1 lb•in)
Wire size	(22...14 AWG) solid (22...16 AWG) stranded
Wire type	Cu-90 °C (194 °F)
IEC input compatibility	Type 1+
Replacement connector	1746-N3 (1 connector, 40 terminals)
Vendor ID code	1
Product type code	7
Product code	76
Enclosure type rating	None (open-style)

Certifications - 1769-IQ32T

Certification ⁽¹⁾	1769-IQ32T
c-UL	C-UL certified (under CSA C22.2 No. 142) UL 508 listed Class I, Division 2 Group A,B,C,D Hazardous Locations (UL 1604, C-UL under CSA C22.2 No. 213)
CE	CE compliant for all applicable directives
C-Tick	C-Tick compliant for all applicable directives

⁽¹⁾ When marked. See the Product Certification link at <http://www.ab.com> for Declarations of Conformity, Certificates, and other certification details.

1769-IQ6XOW4

Compact combination 24V DC sink/source input and & AC/DC relay output module

Simplified Input Circuit Diagram

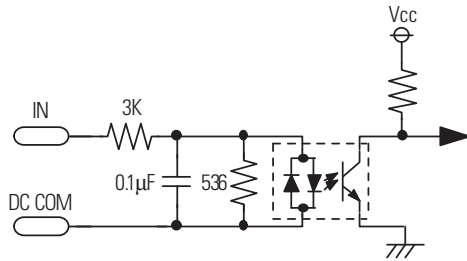

Simplified Output Circuit Diagram

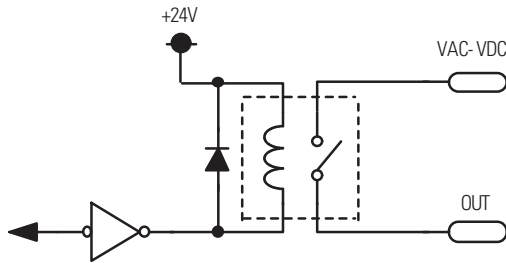

1769-IQ6XOW4

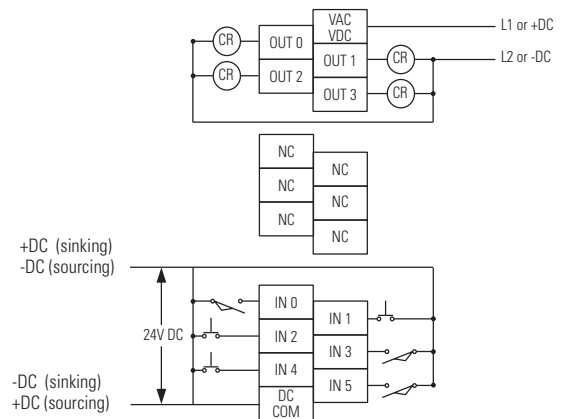

Technical Specifications - 1769-IQ6XOW4

Attribute	1769-IQ6XOW4
Current draw @ 5.1V	105 mA
Current draw @ 24V	50 mA
Heat dissipation, max	2.75 W
Off-state voltage, max	11V DC
Isolation voltage	Verified by one of the following dielectric tests: 1200V AC for 1 s or 1697V DC for 1 s, input group to bus, output group to bus, and input group to output group 75V DC working voltage (IEC Class 2 reinforced insulation)
Weight, approx.	280 g (0.61 lb)
Dimensions (HxWxD), approx.	118 x 35 x 87 mm (4.65 x 1.38 x 3.43 in.) Height with mounting tabs 138 mm (5.43 in.)
Slot width	1
Module location	DIN rail or panel mount
Power supply	1769-PA2, 1769-PB2, 1769-PA4, 1769-PB4
Power supply distance rating	8 modules
Terminal screw torque	0.68 N•m (6 lb•in)
Retaining screw torque	0.46 N•m (4.1 lb•in)
Wire size	(22...14 AWG) solid (22...16 AWG) stranded

Technical Specifications - 1769-IQ6XOW4

Attribute	1769-IQ6XOW4
Wire type	Cu-90 °C (194 °F)
IEC input compatibility	Type 1+
Replacement terminal block	1769-RTBN18 (1 per kit)
Replacement door label	1769-RL1 (2 per kit)
Replacement door	1769-RD (2 per kit)
Vendor ID code	1
Product type code	7
Product code	66
Enclosure type rating	None (open-style)

1769-IQ6XOW4 Input Specifications

Attribute	1769-IQ6XOW4
Inputs	6
Voltage category	24V DC sink/source
Operating voltage range	10...30V DC @ 30 °C (86 °F) 10...26.4V DC @ 60 °C (140 °F)
Delay, on	8 ms
Delay, off	8 ms
Off-state voltage, max	5V DC
Off-state current, max	1.5 mA
On-state voltage, mi	10V DC
On-state current, min	2.0 mA
Inrush current, max	250 mA
Input impedance, nom	3 k Ω
IEC input compatibility	Type 3

1769-IQ6XOW4 Output Specifications

Attribute	1769-IQ6XOW4
Outputs	4
Voltage category	AC/DC normally open relay contacts
Operating voltage range	5...265V AC 5...125V DC
Delay, on	10 ms
Delay, off	10 ms
Off-state leakage, max	0 mA
On-state current, min	10 mA @ 5V DC
Current per point, max	2.5 A
Current per module, max	8 A

Relay Contact Ratings - 1769-IQ6XOW4

Volts, max	Continuous Amps per Point, max	Amperes ⁽¹⁾		Voltamperes		NEMA ICS 2-125
		Make	Break	Make	Break	
240V AC	2.5 A	7.5 A	0.75 A	1800 VA	180 VA	C300
120V AC		15 A	1.5 A			
125V DC	1.0 A	0.22 A ⁽²⁾		28 VA		R150
24V DC	2.0 A	1.2 A ⁽²⁾		28 VA		—

⁽¹⁾ Connecting surge suppressors across your external inductive load will extend the life of the relay contacts.

⁽²⁾ For DC voltage applications, the make/break ampere rating for relay contacts can be determined by dividing 28 VA by the applied DC voltage. For example, 28 VA/48V DC = 0.58A. For DC voltage applications less than 48V, the make/break ratings for relay contacts cannot exceed 2A.

Certifications - 1769-IQ6XOW4

Certification ⁽¹⁾	1769-IQ6XOW4
c-UL	C-UL certified (under CSA C22.2 No. 142) UL 508 listed Class I, Division 2 Group A,B,C,D Hazardous Locations (UL 1604, C-UL under CSA C22.2 No. 213)
CE	CE compliant for all applicable directives
C-Tick	C-Tick compliant for all applicable directives

⁽¹⁾ When marked. See the Product Certification link at <http://www.ab.com> for Declarations of Conformity, Certificates, and other certification details.

1769-IR6

Compact RTD/resistance input module

Two Wire RTD Configuration

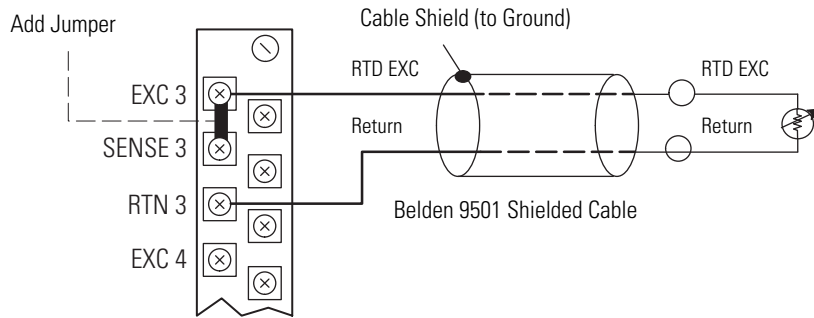

Three Wire RTD Configuration

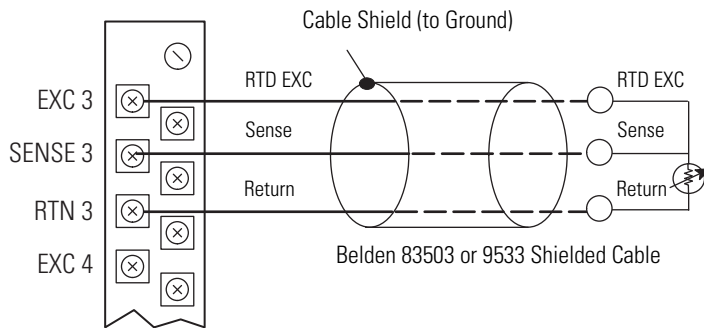

Four Wire RTD Configuration

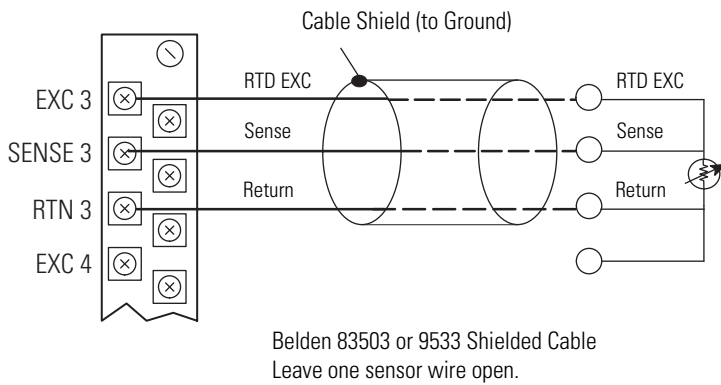

Two Wire Potentiometer Configuration

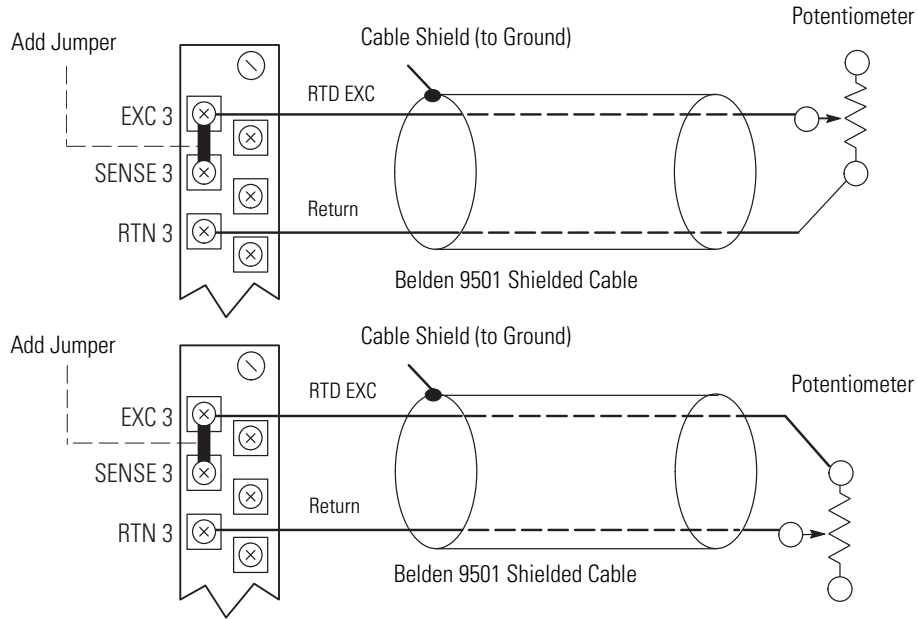

Three Wire Potentiometer Configuration

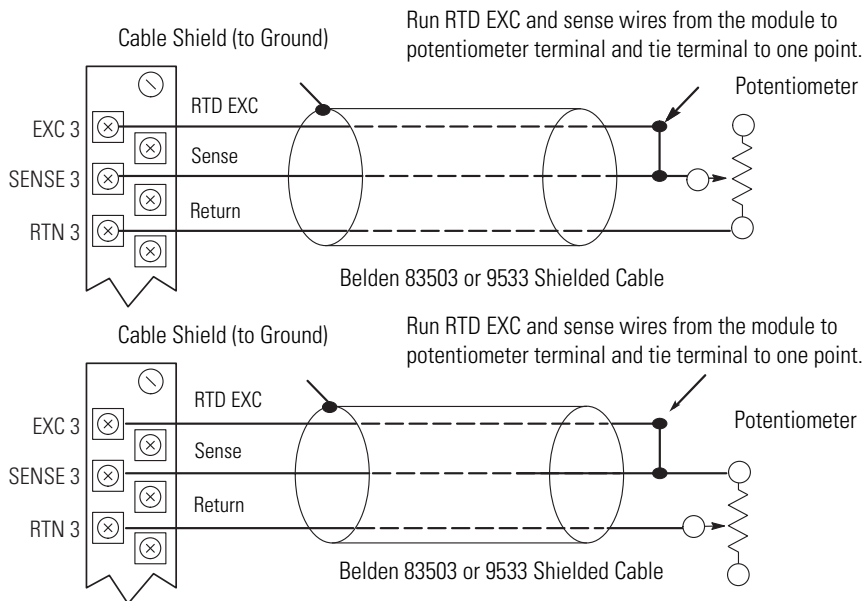

The data can be configured as:

Data Formats for RTD Temperature Ranges for 0.5 and 1.0 mA Excitation Current

RTD Input Type	Engineering Units x1		Engineering Units x10		Scaled-for-PID	Proportional Counts
	0.1 °C	0.1 °F	1.0 °C	1.0 °F		
100 Ω Platinum 385	-2000...+8500	-3280...+15620	-200...+850	-328...+1562	0...16383	-32768...+32767
200 Ω Platinum 385	-2000...+8500	-3280...+15620	-200...+850	-328...+1562	0...16383	-32768...+32767
500 Ω Platinum 385	-2000...+8500	-3280...+15620	-200...+850	-328...+1562	0...16383	-32768...+32767
1000 Ω Platinum 385	-2000...+8500	-3280...+15620	-200...+850	-328...+1562	0...16383	-32768...+32767
100 Ω Platinum 3916	-2000...+6300	-3280...+11660	-200...+630	-328...+1166	0...16383	-32768...+32767
200 Ω Platinum 3916	-2000...+6300	-3280...+11660	-200...+630	328...+1166	0...16383	-32768...+32767
500 Ω Platinum 3916	-2000...+6300	-3280...+11660	-200...+630	328...+1166	0...16383	-32768...+32767
1000 Ω Platinum 3916	-2000...+6300	-3280...+11660	-200...+630	328...+1166	0...16383	-32768...+32767
10 Ω Copper 426	-1000...+2600	-1480...+5000	+100...+260	-148...+500	0...16383	-32768...+32767
120 Ω Nickel 618	-1000...+2600	-1480...+5000	-100...+260	-148...+500	0...16383	-32768...+32767
120 Ω Nickel 672	-800...+2600	-1120...+5000	-80...+260	-112...+500	0...16383	-32768...+32767
604 Ω Nickel Iron 518	-1000...+2600	-3280...+1560	-100...+200	-328...+156	0...16383	-32768...+32767

Temperature Range - 1769-IR6

RTD Type ⁽¹⁾		Temperature Range Using 0.5 mA Excitation	Temperature Range Using 1.0 mA Excitation
Platinum 385	100 Ω	-200...850 °C (-328...1562 °F)	-200...850 °C (-328...1562 °F)
	200 Ω	-200...850 °C (-328...1562 °F)	-200...850 °C (-328...1562 °F)
	500 Ω	-200...850 °C (-328...1562 °F)	-200...850 °C (-328...1562 °F)
	1000 Ω	-200...850 °C (-328...1562 °F)	N/A
Platinum 3916	100 Ω	-200C...630 °C (-328...1166 °F)	-200...630 °C (-328...1166 °F)
	200 Ω	-200C...630 °C (-328...1166 °F)	-200...630 °C (-328...1166 °F)
	500 Ω	-200C...630 °C (-328...1166 °F)	-200...630 °C (-328...1166 °F)
	1000 Ω	-200C...630 °C (-328...1166 °F)	N/A
Copper 426	10 Ω	N/A	-100 to 260 °C (-148...500 °F)
Nickel 618 ⁽²⁾	120 Ω	-100...260 °C (-148...500 °F)	-100...260 °C (-148...500 °F)
Nickel 672	120 Ω	-80...260 °C (-112...500 °F)	-80...260 °C (-112...500 °F)
Nickel-Iron 518	604 Ω	-200...180 °C (-328...338 °F)	-100...+200 °C (-148...392 °F)

⁽¹⁾ Digits following the RTD type represent the temperature coefficient of resistance (α), which is defined as the resistance change per Ω per °C. For instance, platinum 385 refers to a platinum RTD with $\alpha = 0.00385 \Omega/\Omega \cdot ^\circ\text{C}$, or simply $0.00385/^\circ\text{C}$.

⁽²⁾ Actual value at 0°C is 100 Ω per DIN standard.

Resistance Device Compatibility - 1769-IR6

Resistance Device Type	Resistance Range (0.5 mA Excitation)	Resistance Range (1.0 mA Excitation)
150 Ω	0...150 Ω	0...150 Ω
500 Ω	0...500 Ω	0...500 Ω
1000 Ω	0...1000 Ω	0...1000 Ω
3000 Ω	0...3000 Ω	N/A

Technical Specifications - 1769-IR6

Attribute	1769-IR6
Inputs	6 RTD inputs
Input range	0...150 Ω 0...500 Ω 0...1000 Ω 0...3000 Ω
Resolution	Input filter and configuration dependent
Sensors supported	100, 200, 500, 1000 Ω Platinum 385 100, 200, 500, 1000 Ω Platinum 3916 120 Ω Nickel 672 120 Ω Nickel 618 10 Ω Nickel-iron 518
Current draw @ 5.1V	100 mA
Current draw @ 24V	45 mA
Heat dissipation, max	1.5 W
Converter type	Sigma Delta
Common mode voltage range	± 10 V DC max
Common mode rejection	110 dB @ 50 Hz with the 10 or 50 Hz filter selected 110 dB @ 60 Hz with the 10 or 60 Hz filter selected
Normal mode rejection ratio	70 dB @ 50 Hz with the 10 or 50 Hz filter selected 70 dB @ 60 Hz with the 10 or 60 Hz filter selected
Cable impedance, max	25 Ω
Input impedance	> 10 M Ω
Accuracy @ 25 °C (77 °F) ⁽¹⁾	± 0.5 °C (0.9 °F) for Pt 385 ± 0.4 °C (0.72 °F) for Pt 3916 ± 0.2 °C (0.36 °F) for Ni ± 0.3 °C (0.54 °F) for NiFe ± 0.6 °C (1.08 °F) for Cu ± 0.15 Ω for 150 Ω range ± 0.5 Ω for 500 Ω range ± 1.0 Ω for 1000 Ω range ± 1.5 Ω for 3000 Ω range
Accuracy @ 0...60 °C (32...140 °F) ⁽¹⁾	± 0.9 °C (1.62 °F) for Pt 385 ± 0.8 °C (1.44 °F) for Pt 3916 ± 0.4 °C (0.72 °F) for Ni ± 0.5 °C (0.9 °F) for NiFe ± 1.1 °C (1.98 °F) for Cu ± 0.25 Ω for 150 Ω range ± 0.8 Ω for 500 Ω range ± 1.5 Ω for 1000 Ω range ± 2.5 Ω for 3000 Ω range
Accuracy drift @ 0...60 °C (32...140 °F) ⁽¹⁾	± 0.026 °C/°C (0.026 °F/°F) for Pt 385 ± 0.023 °C/°C (0.023 °F/°F) for Pt 3916 ± 0.012 °C/°C (0.012 °F/°F) for Ni ± 0.015 °C/°C (0.015 °F/°F) for NiFe ± 0.032 °C/°C (0.032 °F/°F) for Cu ± 0.007 Ω /°C (± 0.013 Ω /°F) for 150 Ω ± 0.023 Ω /°C (± 0.041 Ω /°F) for 500 Ω ± 0.043 Ω /°C (± 0.077 Ω /°F) for 1000 Ω ± 0.072 Ω /°C (± 0.130 Ω /°F) for 3000 Ω
Nonlinearity	$\pm 0.05\%$
Repeatability ⁽²⁾	± 0.01 °C (0.018 °F) for Ni and NiFe ± 0.2 °C (0.36 °F) for other RTD inputs ± 0.04 W for 150 W resistances ± 0.2 W for other resistances
Open circuit detection time ⁽³⁾	6 ms...303s

Technical Specifications - 1769-IR6

Attribute	1769-IR6
Isolation voltage	720V DC for 1 minute, optical and magnetic (qualification), channel to bus 30V AC/30V DC working voltage (IEC Class 2 reinforced insulation)
Weight, approx.	276 g (0.61 lb)
Dimensions (HxWxD), approx.	118 x 35 x 87 mm (4.65 x 1.38 x 3.43 in.) Height with mounting tabs 138 mm (5.43 in.)
Slot width	1
Module location	DIN rail or panel mount
Power supply	1769-PA2, 1769-PB2, 1769-PA4, 1769-PB4
Power supply distance rating	8 modules
Terminal screw torque	0.68 N•m (6 lb•in)
Retaining screw torque	0.46 N•m (4.1 lb•in)
Recommended cable	2-wire configuration: Belden 9501 or equivalent 3-wire configuration: Belden 9533 or equivalent 4-wire configuration: Belden 83503 or equivalent
Wire size	(22...14 AWG) solid (22...16 AWG) stranded
Wire type	Cu-90 °C (194 °F)
IEC input compatibility	Type 1+
Replacement terminal block	1769-RTBN18 (1 per kit)
Replacement door label	1769-RL2 series B (2 per kit)
Replacement door	1769-RD (2 per kit)
Vendor ID code	1
Product type code	10
Product code	37
Enclosure type rating	None (open-style)

(1) Accuracy is dependent upon the Analog/Digital converter output rate selection, excitation current selection, data format, and input noise.

(2) Repeatability is the ability of the input module to register the same reading in successive measurements for the same input signal.

(3) Open-circuit detection time is equal to channel update time.

RTD Accuracy and Temperature Drift - 1769-IR6

RTD Type		Scaled Accuracy Max 25 °C (77 °F) with Calibration	Scaled Accuracy Max 0...60 °C (32...140 °F) with Calibration	Temperature Drift Max from 25 °C (77 °F) without Calibration
Copper 426	10 Ω	±0.6 °C (1.08 °F)	±1.1 °C (1.98 °F)	±0.032 °C/°C (0.032 °F/°F)
Nickel 618	120 Ω	±0.2 °C (±0.36 °F)	±0.4 °C (±0.72 °F)	±0.012 °C/°C (±0.012 °F/°F)
Nickel 672	120 Ω	±0.2 °C (±0.36 °F)	±0.4 °C (±0.72 °F)	±0.012 °C/°C (±0.012 °F/°F)
Nickel-Iron 518	604 Ω	±0.3 °C (±0.54 °F)	±0.5 °C (±0.9 °F)	±0.015 °C/°C (±0.015 °F/°F)

RTD Accuracy and Temperature Drift - 1769-IR6

RTD Type		Scaled Accuracy Max 25 °C (77 °F) with Calibration	Scaled Accuracy Max 0...60 °C (32...140 °F) with Calibration	Temperature Drift Max from 25 °C (77 °F) without Calibration
Platinum 385	100 Ω	±0.5 °C (±0.9 °F)	±0.9 °C (±1.62°F)	±0.026 °C/°C (±0.026 °F/°F)
	200 Ω	±0.5 °C (±0.9 °F)	±0.9 °C (±1.62°F)	±0.026 °C/°C (±0.026 °F/°F)
	500 Ω	±0.5 °C (±0.9 °F)	±0.9 °C (±1.62°F)	±0.026 °C/°C (±0.026 °F/°F)
	1000 Ω	±0.5 °C (±0.9 °F)	±0.9 °C (±1.62°F)	±0.026 °C/°C (±0.026 °F/°F)
Platinum 3916	100 Ω	±0.4 °C (±0.72 °F)	±0.8 °C (±1.44°F)	±0.023 °C/°C (±0.023 °F/°F)
	200 Ω	±0.4 °C (±0.72 °F)	±0.8 °C (±1.44°F)	±0.023 °C/°C (±0.023 °F/°F)
	500 Ω	±0.4 °C (±0.72 °F)	±0.8 °C (±1.44°F)	±0.023 °C/°C (±0.023 °F/°F)
	1000 Ω	±0.4 °C (±0.72 °F)	±0.8 °C (±1.44°F)	±0.023 °C/°C (±0.023 °F/°F)

RTD Standards - 1769-IR6

RTD Type	α ⁽³⁾	IEC-751 1983, Amend. 2 1995	DIN 43760 1987	SAMA ⁽⁴⁾ Standard RC21-4-1966	Japanese Industrial Standard JIS C1604-1989	Japanese Industrial Standard JIS C1604-1997	Minco ⁽⁵⁾
100 Ω Pt	0.00385	X	X			X	
200 Ω Pt	0.00385	X	X			X	
500 Ω Pt	0.00385	X	X			X	
1000 Ω Pt	0.00385	X	X			X	
100 Ω Pt	0.03916				X		
200 Ω Pt	0.03916				X		
500 Ω Pt	0.03916				X		
1000 Ω Pt	0.03916				X		
10 Ω Cu ⁽¹⁾	0.00426			X			
120 Ω Ni ⁽²⁾	0.00618		X				
120 Ω Ni	0.00372						X
604 Ω NiFe	0.00518						X

⁽¹⁾ Actual value at 0 °C (32 °F) is 9.04 2Ω per SAMA standard RC21-4-1966.

⁽²⁾ Actual value at 0 °C (32 °F) is 100 Ω per SAMA standard RC21-4-1966.

⁽³⁾ α is the temperature coefficient of resistance which is defined as the resistance change per ohm per °C.

⁽⁴⁾ Scientific Apparatus Makers Association

⁽⁵⁾ Minco Type "NA" (Nickel) and Minco Type "FA" (Nickel-Iron)

Certifications - 1769-IR6

Certification ⁽¹⁾	1769-IR6
c-UL	C-UL certified (under CSA C22.2 No. 142) UL 508 listed Class I, Division 2 Group A,B,C,D Hazardous Locations (UL 1604, C-UL under CSA C22.2 No. 213)
CE	CE compliant for all applicable directives

⁽¹⁾ When marked. See the Product Certification link at <http://www.ab.com> for Declarations of Conformity, Certificates, and other certification details.

1769-IT6

Compact Thermocouple/mV input module

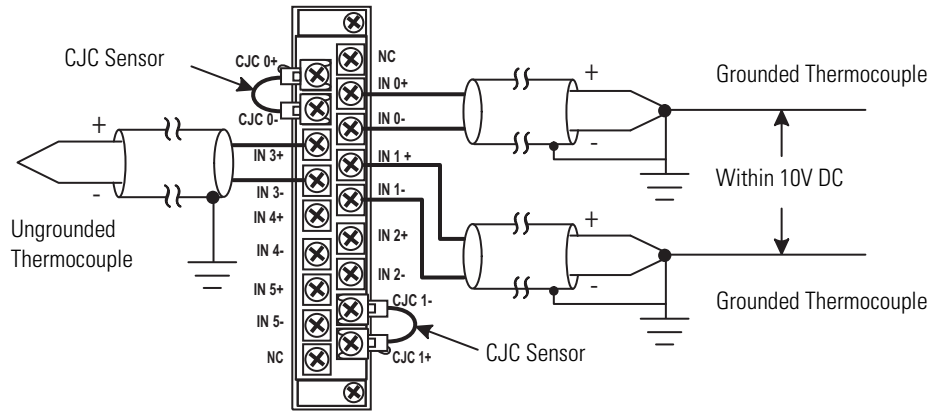

Thermocouple Type	°C Temperature Range	°F Temperature Range
J	-210...+1200 °C	-346...+2192 °F
K	-270...+1370 °C	-454...+2498 °F
T	-270...+400 °C	-454...+752 °F
E	-270...+1000 °C	-454...+1832 °F
R	0...+1768 °C	+32...+3214 °F
S	0...+1768 °C	+32...+3214 °F
B	+300...+1820 °C	+572...+3308 °F
N	-210...+1300 °C	-346...+2372 °F
C	0...+2315 °C	+32...+ 4199 °F

Millivolt Input Type	Range
± 50 mV	-50...+50 mV
± 100 mV	-100...+100 mV

The data can be configured as:

Input Type	Engineering Units x1		Engineering Units x10		Scaled-for-PID	Raw/Proportional Data	Percent Range
	0.1 °C	0.1 °F	1.0 °C	1.0 °F			
J	-2100...+12000	-3460...+21920	-210...+1200	-346...+2192	0...+16383	-32767...+32767	0...+10000
K	-2700...+13700	-4540...+24980	-270...+1370	-454...+2498	0...+16383	-32767...+32767	0...+10000
T	-2700...+4000	-4540...+7520	-270...+400	-454...+752	0...+16383	-32767...+32767	0...+10000
E	-2700...+10000	-4540...+18320	-270...+1000	-454...+1832	0...+16383	-32767...+32767	0...+10000
R	0...+17680	+320...32140	0...+1768	+32...3214	0...+16383	-32767...+32767	0...+10000
S	0...+17680	+320...32140	0...+1768	+32...3214	0...+16383	-32767...+32767	0...+10000
B	+3000...18200	+5720...32767 ⁽¹⁾	+300...1820	+572...3308	0...+16383	-32767...+32767	0...+10000
N	-2100...+13000	-3460...+23720	-210...+1300	-346...+2372	0...+16383	-32767...+32767	0...+10000
C	0...+23150	+320...32767 ⁽¹⁾	0...+2315	+32...4199	0...+16383	-32767...+32767	0...+10000
±50 mV	-5000...+5000 ⁽²⁾		-500...+500 ⁽²⁾		0...+16383	-32767...+32767	0...+10000
±100 mV	-10000...10000 ⁽²⁾		-1000...1000 ⁽²⁾		0...+16383	-32767...+32767	0...+10000

⁽¹⁾ Type B and C thermocouples cannot be represented in engineering units x1 (°F) above 3276.7 °F; therefore, it will be treated as an over-range error.

⁽²⁾ When millivolts are selected, the temperature setting is ignored. Analog input data is the same for °C or °F selection.

IMPORTANT

To reduce the effects of electrical noise, install the 1769-IT6 module at least two slots away from the AC power supplies.

Technical Specifications - 1769-IT6

Attribute	1769-IT6
Inputs	6 RTD inputs 2 CJC sensors
Input range	0...150 Ω 0...500 Ω 0...1000 Ω 0...3000 Ω
Resolution	Input filter and configuration dependent
Thermocouples	B, E, J, K, R, S, T, N, C
Current draw @ 5.1V	100 mA
Current draw @ 24V	45 mA
Heat dissipation, max	1.5 W
Converter type	Sigma Delta
Response speed per channel	3...300 ms, depending on input filter and configuration
Rated working voltage ⁽¹⁾	30V AC/30V DC
Common mode voltage range ⁽²⁾	± 10 V DC max
Common mode rejection	115 dB @ 50 Hz with 10 Hz or 50 Hz filter 115 dB @ 60 Hz with 10 Hz or 60 Hz filter
Normal mode rejection ratio	85 dB @ 50 Hz with the 10 or 50 Hz filter selected 85 dB @ 60 Hz with the 10 or 60 Hz filter selected
Cable impedance, max	25 Ω
Input impedance	> 10 M Ω
CJC assembly accuracy	± 1.0 °C (± 1.8 °F)
Nonlinearity (in percent full scale)	$\pm 0.03\%$
Open-circuit detection time	7 ms...2.1 s ⁽³⁾
Overload at input terminals, max	± 35 V DC continuous ⁽⁴⁾
Isolation voltage	720V DC for 1 min (qualification test) 30V AC/30V DC working voltage, group to bus
Weight, approx.	276 g (0.61 lb)
Dimensions (HxWxD), approx.	118 x 35 x 87 mm (4.65 x 1.38 x 3.43 in.) Height with mounting tabs 138 mm (5.43 in.)
Slot width	1
Module location	DIN rail or panel mount
Power supply	1769-PA2, 1769-PB2, 1769-PA4, 1769-PB4
Power supply distance rating	8 modules
Terminal screw torque	0.68 N•m (6 lb•in)
Retaining screw torque	0.46 N•m (4.1 lb•in)

Technical Specifications - 1769-IT6

Attribute	1769-IT6
Recommended cable	2-wire configuration: Belden 9501 or equivalent 3-wire configuration: Belden 9533 or equivalent 4-wire configuration: Belden 83503 or equivalent
Wire size	(22...14 AWG) solid (22...16 AWG) stranded
Wire type	Cu-90 °C (194 °F)
IEC input compatibility	Type 1+
Replacement terminal block	1769-RTBN18 (1 per kit)
Replacement door label	1769-RL2 series B (2 per kit)
Replacement door	1769-RD (2 per kit)
Vendor ID code	1
Product type code	10
Product code	36
Enclosure type rating	None (open-style)

- (1) Rated working voltage is the maximum continuous voltage that can be applied at the input terminal, including the input signal and the value that floats above ground potential (for example, 30V DC input signal and 20V DC potential above ground).
- (2) For proper operation, both the plus and minus input terminals must be within ±10V DC of analog common.
- (3) Open-circuit detection time is equal to the module scan time, which is based on the number of enabled channels, and the filter frequency of each channel.
- (4) Maximum current input is limited due to input impedance.

Repeatability at 25 °C (77 °F) - 1769-IT6

Input Type	Repeatability for 10 Hz Filter ^{(1) (2)}
Thermocouple J	±0.1 °C [±0.18 °F]
Thermocouple N (-110...+1300 °C [-166...+2372 °F])	±0.1 °C [±0.18 °F]
Thermocouple N (-210...-110 °C [-346...-166 °F])	±0.25 °C [±0.45 °F]
Thermocouple T (-170...+400 °C [-274...+752 °F])	±0.1 °C [±0.18 °F]
Thermocouple T (-270...-170 °C [-454...-274 °F])	±1.5 °C [±2.7 °F]
Thermocouple K (-270...+1370 °C [-454...+2498 °F])	±0.1 °C [±0.18 °F]
Thermocouple (-270...-170 °C [-454...-274 °F])	±2.0 °C [±3.6 °F]
Thermocouple E (-220...+1000 °C [-364...+1832 °F])	±0.1 °C [±0.18 °F]
Thermocouple E (-270...-220 °C [-454...-364 °F])	±1.0 °C [±1.8 °F]
Thermocouples S and R	±0.4 °C [±0.72 °F]
Thermocouple C	±0.7 °C [±1.26 °F]
Thermocouple B	±0.2 °C [±0.36 °F]
±50 mV	±6 µV
±100 mV	±6 µV

- (1) Repeatability is the ability of the input module to register the same reading in successive measurements for the same input signal.
- (2) Repeatability at any other temperature in the 0 to 60°C (32 to 140°F) range is the same as long as the temperature is stable.

Accuracy - 1769-IT6

Input Type ⁽¹⁾	With Autocalibration Enabled		Without Autocalibration
	Accuracy ^{(2) (3)} for 10, 50 and 60 Hz Filters (max)		Temperature Drift Max ^{(2) (4)}
	@ 25 °C (77 °F) Ambient	@ 0...60 °C (32...140 °F) Ambient	@ 0...60 °C (32...140 °F) Ambient
Thermocouple J (-210...1200 °C [-346...2192 °F])	±0.6 °C [± 1.1 °F]	±0.9 °C [± 1.7 °F]	±0.0218 °C/°C [±0.0218 °F/°F]
Thermocouple N (-200...+1300 °C [-328...2372 °F])	±1 °C [± 1.8 °F]	±1.5 °C [±2.7 °F]	±0.0367 °C/°C [±0.0367 °F/°F]
Thermocouple N (-210...-200 °C [-346...-328 °F])	±1.2 °C [±2.2 °F]	±1.8 °C [±3.3 °F]	±0.0424 °C/°C [±0.0424 °F/°F]
Thermocouple T (-230...+400 °C [-382...+752 °F])	±1°C [± 1.8°F]	±1.5 °C [±2.7 °F]	±0.0349 °C/°C [±0.0349 °F/°F]
Thermocouple T (-270...-230 °C [-454...-382 °F])	±5.4 °C [± 9.8 °F]	±7.0 °C [±12.6 °F]	±0.3500 °C/°C [±0.3500 °F/°F]
Thermocouple K (-230...+1370 °C [-382...+2498 °F])	±1 °C [± 1.8 °F]	±1.5 °C [±2.7 °F]	±0.4995 °C/°C [±0.4995 °F/°F]
Thermocouple K (-270...-225 °C [-454...-373 °F])	±7.5 °C [± 13.5 °F]	±10 °C [± 18 °F]	±0.0378 °C/°C [±0.0378 °F/°F]
Thermocouple E (-210...+1000 °C [-346...+1832 °F])	±0.5 °C [± 0.9 °F]	±0.8 °C [±1.5 °F]	±0.0199 °C/°C [±0.0199 °F/°F]
Thermocouple E (-270...-210 °C [-454...-346 °F])	±4.2 °C [± 7.6 °F]	±6.3 °C [±11.4 °F]	±0.2698 °C/°C [±0.2698 °F/°F]
Thermocouple R	±1.7 °C [± 3.1 °F]	±2.6 °C [± 4.7 °F]	±0.0613 °C/°C [±0.0613 °F/°F]
Thermocouple S	±1.7 °C [± 3.1 °F]	±2.6 °C [± 4.7 °F]	±0.0600 °C/°C [±0.0600 °F/°F]
Thermocouple C	±1.8 °C [±3.3 F]	±3.5 °C [±6.3 °F]	±0.0899 °C/°C [±0.0899 °F/°F]
Thermocouple B	±3.0 °C [±5.4 °F]	±4.5 °C [±8.1 °F]	±0.1009 °C/°C [±0.1009 °F/°F]
±50 mV	±15 µV	±25 µV	±0.44 µV/°C [±0.80 µV/°F]
±100 mV	±20 µV	±30 µV	±0.69 µV/°C [±0.125 µV/°F]

- (1) The module uses the National Institute of Standards and Technology (NIST) ITS-90 standard for thermocouple linearization.
- (2) Accuracy and temperature drift information does not include the affects of errors or drift in the cold junction compensation circuit.
- (3) Accuracy is dependent upon the analog/digital converter output rate selection, data format, and input noise.
- (4) Temperature drift with autocalibration is slightly better than without autocalibration.

Certifications - 1769-IT6

Certification ⁽¹⁾	1769-IT6
c-UL	C-UL certified (under CSA C22.2 No. 142) UL 508 listed Class I, Division 2 Group A,B,C,D Hazardous Locations (UL 1604, C-UL under CSA C22.2 No. 213)
CE	CE compliant for all applicable directives

(1) When marked. See the Product Certification link at <http://www.ab.com> for Declarations of Conformity, Certificates, and other certification details.

1769-0A8

Compact 100/240V AC solid state output module

Simplified Output Circuit Diagram

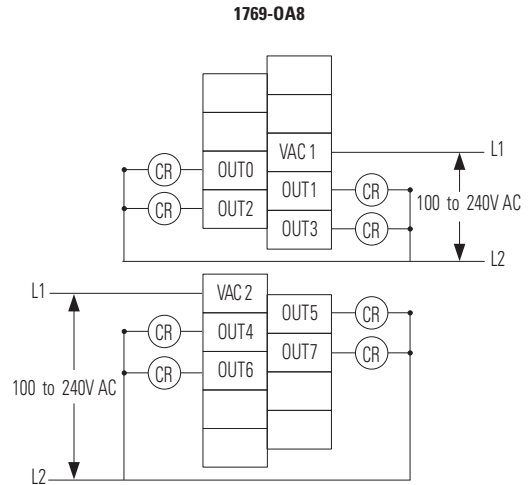
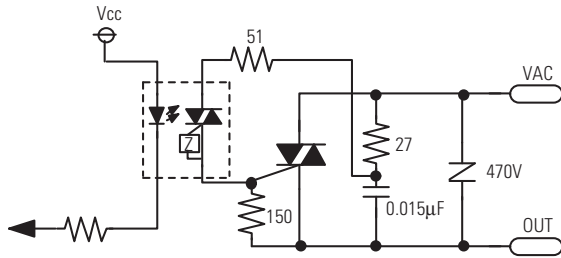

Technical Specifications - 1769-0A8

Attribute	1769-0A8
Outputs	8 (4 points/group)
Voltage category	100/240V AC
Operating voltage range	85...265V AC 47...63 Hz
Output delay, on ⁽¹⁾	1/2 cycle
Output delay, off ⁽¹⁾	1/2 cycle
Current draw @ 5.1V	145 mA
Heat dissipation, max	2.12 W
Off-state leakage current, max ⁽²⁾	2.0 mA @ 132V AC 2.5 mA @ 265V AC
On-state current, max	10 mA
On-state voltage drop, max	1.5V peak @ 2 A
Current per point, max	0.25 A @ 60 °C 0.5 A @ 30 °C
Current per module, max	2 A @ 60 °C 4 A @ 30 °C
Surge current ⁽³⁾	10 A for 25 ms, repeatable every 2 s
Isolation voltage	Verified by one of the following dielectric tests: 1836V AC for 1 s or 2596V DC for 1 s, group to group 265V AC working voltage (basic insulation) 150V AC working voltage (IEC Class 2 reinforced insulation)
Weight, approx.	280 g (0.61 lb)
Dimensions (HxWxD), approx.	118 x 35 x 87 mm (4.65 x 1.38 x 3.43 in.) Height with mounting tabs 138 mm (5.43 in.)
Slot width	1
Module location	DIN rail or panel mount

Technical Specifications - 1769-OA8

Attribute	1769-OA8
Power supply	1769-PA2, 1769-PB2, 1769-PA4, 1769-PB4
Power supply distance rating	8 modules
Terminal screw torque	0.68 N•m (6 lb•in)
Retaining screw torque	0.46 N•m (4.1 lb•in)
Wire size	(22...14 AWG) solid (22...16 AWG) stranded
Wire type	Cu-90 °C (194 °F)
Replacement terminal block	1769-RTBN10 (1 per kit)
Replacement door label	1769-RL1 (2 per kit)
Replacement door	1769-RD (2 per kit)
Vendor ID code	1
Product type code	7
Product code	84
Enclosure type rating	None (open style)

(1) Triac outputs turn on and off at AC line zero cross.

(2) To limit the effects of leakage current through solid state outputs, a loading resistor can be connected in parallel with your load. For 120V AC operation, use a 15 k Ω , 2W resistor. For 240V AC operation use a 5 k Ω , 5W resistor.

(3) Connecting surge suppressors across your external load will extend the life of the triac outputs.

Temperature Derating - 1769-OA8

1769-OA8 Maximum Amperes per Point vs. Temperature

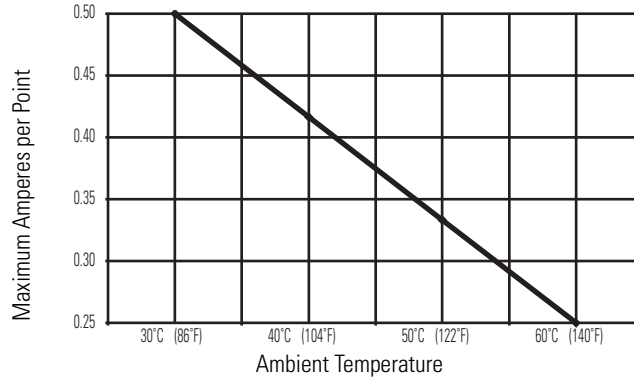

1769-OA8 Maximum Amperes per Module vs. Temperature

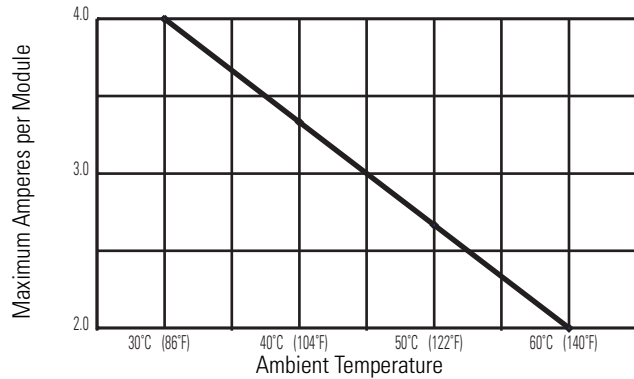

Certifications - 1769-OA8

Certification ⁽¹⁾	1769-OA8
c-UL	C-UL certified (under CSA C22.2 No. 142) UL 508 listed Class I, Division 2 Group A,B,C,D Hazardous Locations (UL 1604, C-UL under CSA C22.2 No. 213)
CE	CE compliant for all applicable directives
C-Tick	C-Tick compliant for all applicable directives

⁽¹⁾ When marked. See the Product Certification link at <http://www.ab.com> for Declarations of Conformity, Certificates, and other certification details.

1769-0A16

Compact 120/240V AC solid state output module

Simplified Output Circuit Diagram

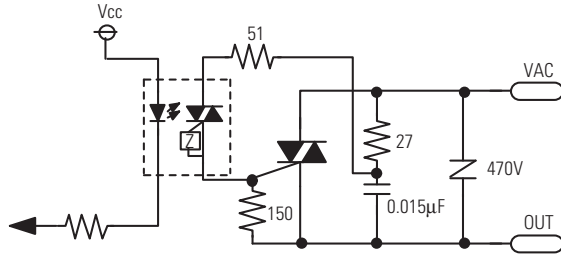

1769-0A16

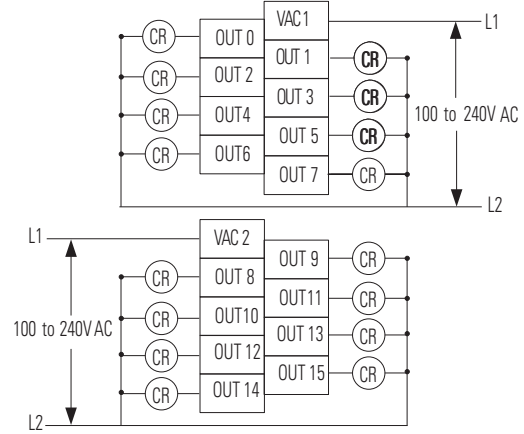

Technical Specifications - 1769-0A16

Attribute	1769-0A16
Outputs	16 (8 points/group)
Voltage category	100/240V AC
Operating voltage range	85...265V AC 47...63 Hz
Output delay, on ⁽¹⁾	1/2 cycle
Output delay, off ⁽¹⁾	1/2 cycle
Current draw @ 5.1V	225 mA
Heat dissipation, max	4.9 W
Off-state leakage current, max ⁽²⁾	2.0 mA @ 132V AC 2.5 mA @ 265V AC
On-state current, max	10 mA
On-state voltage drop, max	1.5V peak @ 2 A
Current per point, max	0.25 A @ 60 °C 0.5 A @ 30 °C
Current per module, max	2 A @ 60 °C 4 A @ 30 °C
Surge current ⁽³⁾	5 A for 25 ms, repeatable every 2 s
Isolation voltage	Verified by one of the following dielectric tests: 1836V AC for 1 s or 2596V DC for 1 s, output point to bus 265V AC working voltage (IEC Class 2 reinforced insulation) Verified by one of the following dielectric tests: 1836V AC for 1 s or 2596V DC for 1 s, output point to bus 265V AC working voltage (basic insulation) 150V AC working voltage (IEC Class 2 reinforced insulation)
Weight, approx.	280 g (0.61 lb)

Technical Specifications - 1769-OA16

Attribute	1769-OA16
Dimensions (HxWxD), approx.	118 x 35 x 87 mm (4.65 x 1.38 x 3.43 in.) Height with mounting tabs 138 mm (5.43 in.)
Slot width	1
Module location	DIN rail or panel mount
Power supply	1769-PA2, 1769-PB2, 1769-PA4, 1769-PB4
Power supply distance rating	8 modules
Terminal screw torque	0.68 N•m (6 lb•in)
Retaining screw torque	0.46 N•m (4.1 lb•in)
Wire size	(22...14 AWG) solid (22...16 AWG) stranded
Wire type	Cu-90 °C (194 °F)
Replacement terminal block	1769-RTBN18 (1 per kit)
Replacement door label	1769-RL1 (2 per kit)
Replacement door	1769-RD (2 per kit)
Vendor ID code	1
Product type code	7
Product code	93
Enclosure type rating	None (open style)

(1) Triac outputs turn on and off at AC line zero cross.

(2) To limit the effects of leakage current through solid state outputs, a loading resistor can be connected in parallel with your load. For 120V AC operation, use a 15 k Ω , 2W resistor. For 240V AC operation use a 5 k Ω , 5W resistor.

(3) Connecting surge suppressors across your external load will extend the life of the triac outputs.

Temperature Derating - 1769-0A16

1769-0A16 Maximum Amperes per Point vs. Temperature

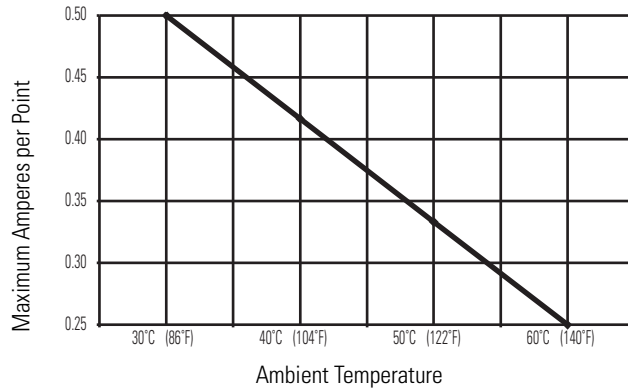

1769-0A16 Maximum Amperes per Module vs. Temperature

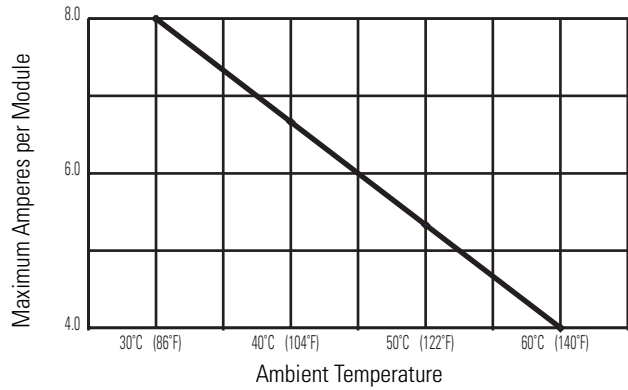

Certifications - 1769-0A16

Certification ⁽¹⁾	1769-0A16
c-UL	C-UL certified (under CSA C22.2 No. 142) UL 508 listed Class I, Division 2 Group A,B,C,D Hazardous Locations (UL 1604, C-UL under CSA C22.2 No. 213)
CE	CE compliant for all applicable directives
C-Tick	C-Tick compliant for all applicable directives

⁽¹⁾ When marked. See the Product Certification link at <http://www.ab.com> for Declarations of Conformity, Certificates, and other certification details.

1769-OB8

Compact solid state 24V DC source, high-current output module

Simplified Output Circuit Diagram

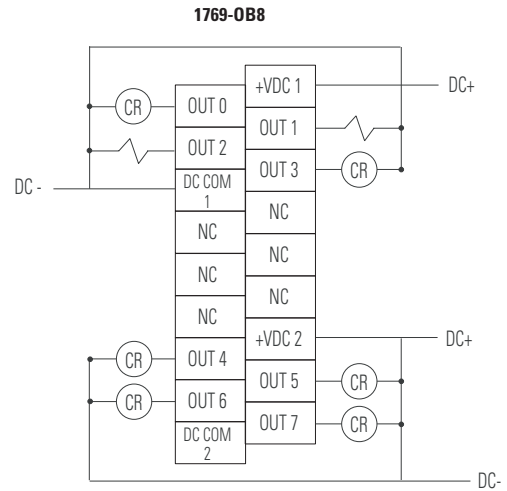
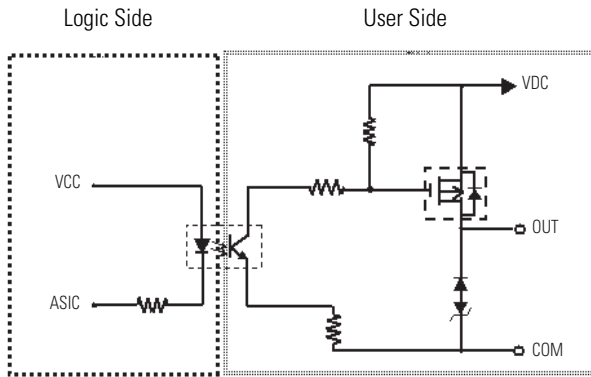

Technical Specifications - 1769-OB8

Attribute	1769-OB8
Outputs	8 (4 points/group)
Voltage category	24V DC source
Operating voltage range	20.4...26.4V DC
Output delay, on	0.1 ms
Output delay, off	1.0 ms @ 60 °C max load 2 A, min V in 20.4V 1.5 ms @ 60 °C max load 1mA, min V in 20.4V
Current draw @ 5.1V	145 mA
Heat dissipation, max	2.20 W
Off-state leakage current, max ⁽¹⁾	1.0 mA @ 26.4V DC
On-state current, min	1.0 mA
On-state voltage drop, max	1.0V DC @ 2 A
Current per point, max	2.0 A @ 60 °C (140 °F)
Current per module, max	8.0 A @ 60 °C (140 °F)
Surge current ⁽²⁾	4 A for 10 ms, repeatable every 2 s
Isolation voltage	Verified by one of the following dielectric tests: 1200V AC for 1 s or 1697V DC for 1 s, output point to bus, and group to group 75V DC working voltage (IEC Class 2 reinforced insulation)
Weight, approx.	280 g (0.61 lb)
Dimensions (HxWxD), approx.	118 x 35 x 87 mm (4.65 x 1.38 x 3.43 in.) Height with mounting tabs 138 mm (5.43 in.)
Slot width	1
Module location	DIN rail or panel mount
Power supply	1769-PA2, 1769-PB2, 1769-PA4, 1769-PB4
Power supply distance rating	8 modules

Technical Specifications - 1769-OB8

Attribute	1769-OB8
Terminal screw torque	0.68 N•m (6 lb•in)
Retaining screw torque	0.46 N•m (4.1 lb•in)
Wire size	(22...14 AWG) solid (22...16 AWG) stranded
Wire type	Cu-90 °C (194 °F)
Replacement terminal block	1769-RTBN18 (1 per kit)
Replacement door label	1769-RL1 (2 per kit)
Replacement door	1769-RD (2 per kit)
Vendor ID code	1
Product type code	7
Product code	70
Enclosure type rating	None (open style)

⁽¹⁾ To limit the effects of leakage current through solid state outputs, a loading resistor can be connected in parallel with your load. Use a 5.6 k Ω , 1/2 W resistor for transistor outputs, 24V DC operation.

⁽²⁾ Use a 1N4004 diode reverse-wired across the load for transistor outputs switching 24V DC inductive loads.

Certifications - 1769-OB8

Certification ⁽¹⁾	1769-OB8
c-UL	C-UL certified (under CSA C22.2 No. 142) UL 508 listed Class I, Division 2 Group A,B,C,D Hazardous Locations (UL 1604, C-UL under CSA C22.2 No. 213)
CE	CE compliant for all applicable directives
C-Tick	C-Tick compliant for all applicable directives

⁽¹⁾ When marked. See the Product Certification link at <http://www.ab.com> for Declarations of Conformity, Certificates, and other certification details.

1769-OB16

Compact solid state 24V DC source output module

Simplified Output Circuit Diagram

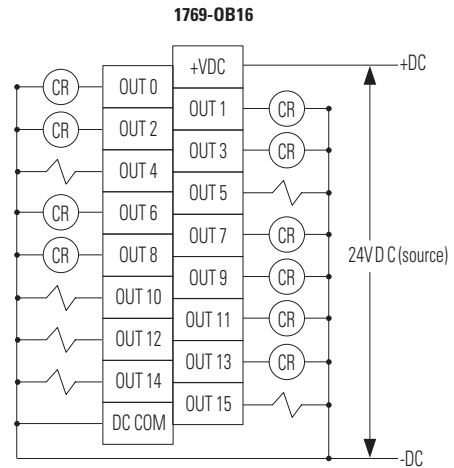
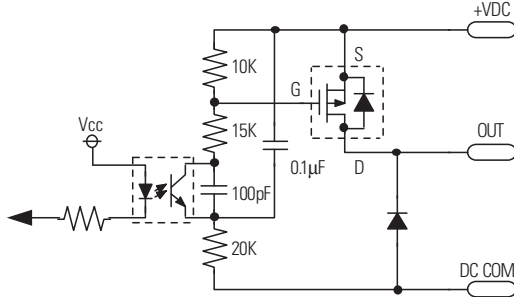

Technical Specifications - 1769-OB16

Attribute	1769-OB16
Outputs	16 (16 points/group)
Voltage category	24V DC source
Operating voltage range	20.4...26.4V DC
Output delay, on	0.1 ms
Output delay, off	1.0 ms
Current draw @ 5.1V	200 mA
Heat dissipation, max	2.11 W
Off-state leakage current, max ⁽¹⁾	1.0 mA @ 26.4V DC
On-state current, min	1.0 mA
On-state voltage drop, max	1.0V DC @ 1 A
Current per point, max	0.5 A @ 60 °C (140 °F) 1.0 A @ 30 °C (86 °F)
Current per module, max	4.0 A @ 60 °C (140 °F) 8.0 A @ 30 °C (86 °F)
Surge current ⁽²⁾	2.0 A for 10 ms, repeatable every 2 s
Isolation voltage	Verified by one of the following dielectric tests: 1200V AC for 1 s or 1697V DC for 1 s, output point to bus 75V DC working voltage (IEC Class 2 reinforced insulation)
Weight, approx.	280 g (0.61 lb)
Dimensions (HxWxD), approx.	118 x 35 x 87 mm (4.65 x 1.38 x 3.43 in.) Height with mounting tabs 138 mm (5.43 in.)
Slot width	1
Module location	DIN rail or panel mount
Power supply	1769-PA2, 1769-PB2, 1769-PA4, 1769-PB4
Power supply distance rating	8 modules

Technical Specifications - 1769-OB16

Attribute	1769-OB16
Terminal screw torque	0.68 N•m (6 lb•in)
Retaining screw torque	0.46 N•m (4.1 lb•in)
Wire size	(22...14 AWG) solid (22...16 AWG) stranded
Wire type	Cu-90 °C (194 °F)
Replacement terminal block	1769-RTBN18 (1 per kit)
Replacement door label	1769-RL1 (2 per kit)
Replacement door	1769-RD (2 per kit)
Vendor ID code	1
Product type code	7
Product code	71
Enclosure type rating	None (open style)

⁽¹⁾ To limit the effects of leakage current through solid state outputs, a loading resistor can be connected in parallel with your load. Use a 5.6 k Ω , 1/2 W resistor for transistor outputs, 24V DC operation.

⁽²⁾ Use a 1N4004 diode reverse-wired across the load for transistor outputs switching 24V DC inductive loads.

Temperature Derating - 1769-OB16

1769-OB16 Maximum Amperes per Point vs. Temperature

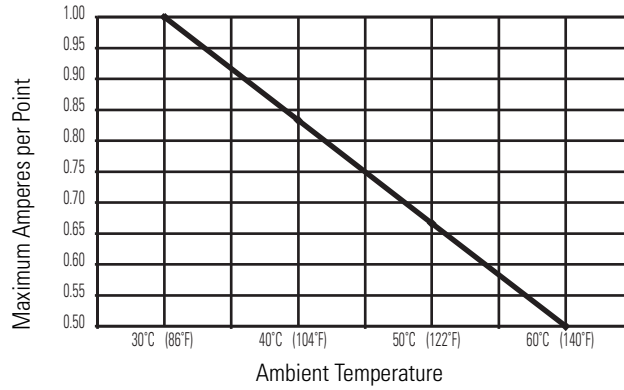

1769-OB16 Maximum Amperes per Module vs. Temperature

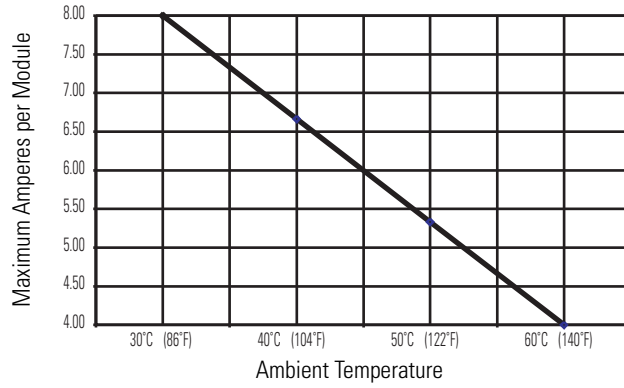

Certifications - 1769-OB16

Certification ⁽¹⁾	1769-OB16
c-UL	C-UL certified (under CSA C22.2 No. 142) UL 508 listed Class I, Division 2 Group A,B,C,D Hazardous Locations (UL 1604, C-UL under CSA C22.2 No. 213)
CE	CE compliant for all applicable directives
C-Tick	C-Tick compliant for all applicable directives

⁽¹⁾ When marked. See the Product Certification link at <http://www.ab.com> for Declarations of Conformity, Certificates, and other certification details.

1769-OB16P

Compact solid state 24V DC source, protected output module

Simplified Output Circuit Diagram

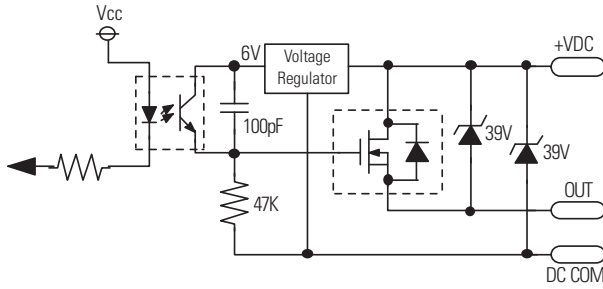

Protection circuit is not shown.

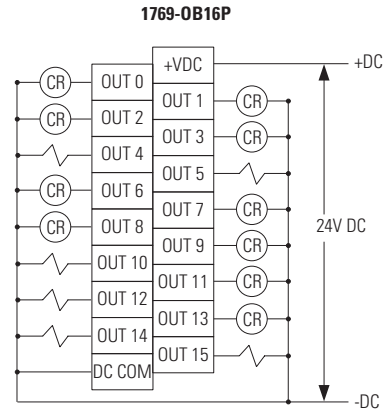

Technical Specifications - 1769-OB16P

Attribute	1769-OB16P
Outputs	16 (16 points/group)
Voltage category	24V DC source
Operating voltage range	20.4...26.4V DC
Output delay, on	1.0 ms
Output delay, off	2.0 ms
Current draw @ 5.1V	160 mA
Heat dissipation, max	2.69 W
Off-state leakage current, max ⁽¹⁾	1.0 mA @ 26.4V DC
On-state current, min	1.0 mA
On-state voltage drop, max	0.5V DC
Current per point, max	0.5 A @ 60 °C (140 °F) 1.0 A @ 30 °C (86 °F)
Current per module, max	4.0 A @ 60 °C (140 °F) 8.0 A @ 30 °C (86 °F)
Surge current ⁽²⁾	2.0 A for 10 ms, repeatable every 1 s
Isolation voltage	Verified by one of the following dielectric tests: 1200V AC for 1 s or 1697V DC for 1 s, output point to bus 75V DC working voltage (IEC Class 2 reinforced insulation)
Weight, approx.	255 g (0.56 lb)
Dimensions (HxWxD), approx.	118 x 35 x 87 mm (4.65 x 1.38 x 3.43 in.) Height with mounting tabs 138 mm (5.43 in.)
Slot width	1
Module location	DIN rail or panel mount
Power supply	1769-PA2, 1769-PB2, 1769-PA4, 1769-PB4
Power supply distance rating	8 modules

Technical Specifications - 1769-OB16P

Attribute	1769-OB16P
Terminal screw torque	0.68 N•m (6 lb•in)
Retaining screw torque	0.46 N•m (4.1 lb•in)
Wire size	(22...14 AWG) solid (22...16 AWG) stranded
Wire type	Cu-90 °C (194 °F)
Replacement terminal block	1769-RTBN18 (1 per kit)
Replacement door label	1769-RL1 (2 per kit)
Replacement door	1769-RD (2 per kit)
Vendor ID code	1
Product type code	7
Product code	91
Enclosure type rating	None (open style)

⁽¹⁾ To limit the effects of leakage current through solid state outputs, a loading resistor can be connected in parallel with your load. Use a 5.6 k Ω , 1/2 W resistor for transistor outputs, 24V DC operation.

⁽²⁾ Use a 1N4004 diode reverse-wired across the load for transistor outputs switching 24V DC inductive loads.

Temperature Derating - 1769-OB16P

1769-OB16P Maximum Amperes per Point vs. Temperature

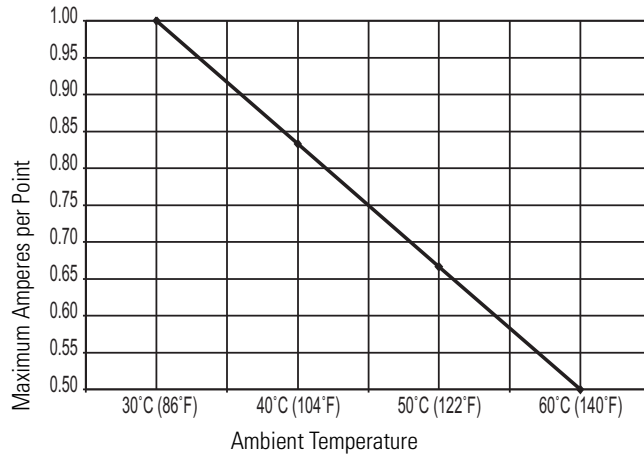

1769-OB16P Maximum Amperes per Module vs. Temperature

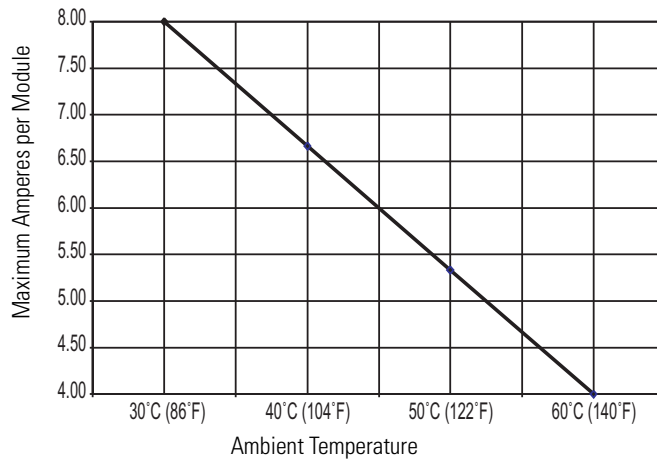

Certifications - 1769-OB16P

Certification ⁽¹⁾	1769-OB16P
c-UL	C-UL certified (under CSA C22.2 No. 142) UL 508 listed Class I, Division 2 Group A,B,C,D Hazardous Locations (UL 1604, C-UL under CSA C22.2 No. 213)
CE	CE compliant for all applicable directives
C-Tick	C-Tick compliant for all applicable directives

⁽¹⁾ When marked. See the Product Certification link at <http://www.ab.com> for Declarations of Conformity, Certificates, and other certification details.

1769-OB32

Compact solid state 24V DC source output module

1769-OB32

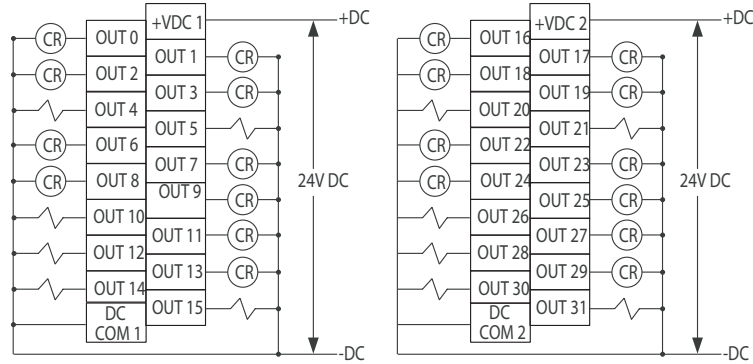

Simplified Output Circuit Diagram

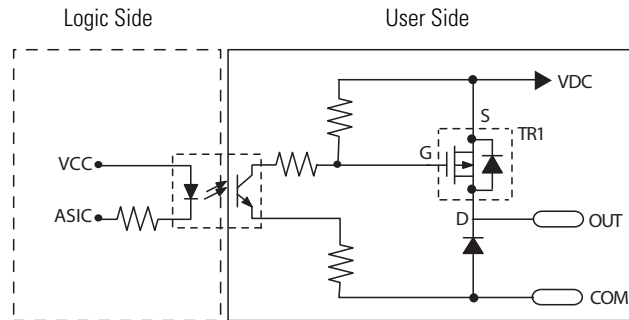

Technical Specifications - 1769-OB32

Attribute	1769-OB32
Outputs	32 (16 points/group)
Voltage category	24V DC source
Operating voltage range	20.4...26.4V DC
Output delay, on	0.1 ms
Output delay, off	1.0 ms
Current draw @ 5.1V	300 mA
Heat dissipation, max	4.5 W
Off-state leakage current, max ⁽¹⁾	1.0 mA @ 26.4V DC
On-state current, min	1.0 mA
On-state voltage drop, max	1.0V DC @ 1 A
Current per point, max	0.5 A @ 60 °C (140 °F) 1.0 A @ 30 °C (86 °F)
Current per module, max	4.0 A @ 60 °C (140 °F) 8.0 A @ 30 °C (86 °F)
Surge current ⁽²⁾	2.0 A for 10 ms, repeatable every 2 s

Technical Specifications - 1769-OB32

Attribute	1769-OB32
Isolation voltage	Verified by one of the following dielectric tests: 1200V AC for 1 s or 1697V DC for 1 s, output point to bus 75V DC working voltage (IEC Class 2 reinforced insulation)
Weight, approx.	450 g (0.992 lb)
Dimensions (HxWxD), approx.	118 x 52.5 x 87 mm (4.65 x 2.07 x 3.43 in.) Height with mounting tabs 138 mm (5.43 in.)
Slot width	1.5
Module location	DIN rail or panel mount
Power supply	1769-PA2, 1769-PB2, 1769-PA4, 1769-PB4
Power supply distance rating	6 modules
Terminal screw torque	0.68 N•m (6 lb•in)
Retaining screw torque	0.46 N•m (4.1 lb•in)
Wire size	(22...14 AWG) solid (22...16 AWG) stranded
Wire type	Cu-90 °C (194 °F)
Replacement terminal block	1769-RTBN18 (1 per kit)
Replacement door label	1769-RL1 (2 per kit)
Replacement door	1769-RD (2 per kit)
Vendor ID code	1
Product type code	7
Product code	73
Enclosure type rating	None (open style)

⁽¹⁾ To limit the effects of leakage current through solid state outputs, a loading resistor can be connected in parallel with your load. Use a 5.6 kΩ, 1/2 W resistor for transistor outputs, 24V DC operation.

⁽²⁾ Use a 1N4004 diode reverse-wired across the load for transistor outputs switching 24V DC inductive loads.

Temperature Derating - 1769-OB32

1769-OB32 Maximum Amperes per Point vs. Temperature

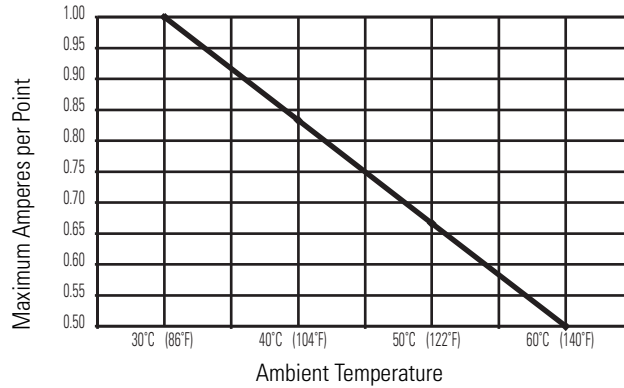

1769-OB32 Maximum Amperes per Module vs. Temperature

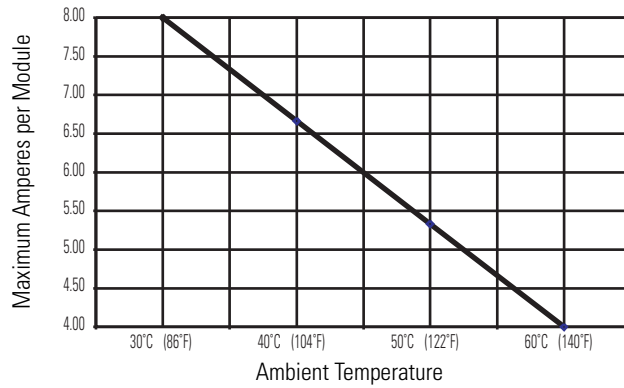

Certifications - 1769-OB32

Certification ⁽¹⁾	1769-OB32
c-UL	C-UL certified (under CSA C22.2 No. 142) UL 508 listed Class I, Division 2 Group A,B,C,D Hazardous Locations (UL 1604, C-UL under CSA C22.2 No. 213)
CE	CE compliant for all applicable directives
C-Tick	C-Tick compliant for all applicable directives

⁽¹⁾ When marked. See the Product Certification link at <http://www.ab.com> for Declarations of Conformity, Certificates, and other certification details.

1769-OB32T

Compact solid state 24V DC source, terminated output module

Simplified Output Circuit Diagram

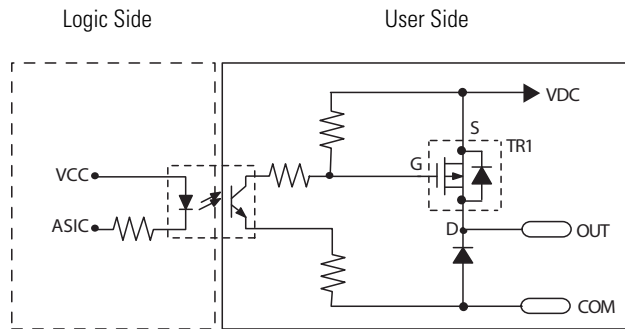

1769-OB32T

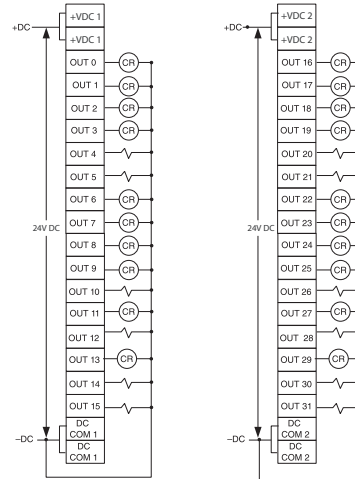

Technical Specifications - 1769-OB32T

Attribute	1769-OB32T
Outputs	32 terminated (16 points/group)
Voltage category	24V DC source
Operating voltage range	10.2...26.4V DC
Output delay, on	0.5 ms
Output delay, off	4.0 ms
Current draw @ 5.1V	220 mA
Heat dissipation, max	4.76 W
Off-state leakage current, max ⁽¹⁾	0.1 mA @ 26.4V DC
On-state current, min	1.0 mA
On-state voltage drop, max	0.3V DC @ 0.5 A
Current per point, max	0.5 A
Current per module, max	4.0 A
Surge current ⁽²⁾	2.0 A for 10 ms, repeatable every 2 s
Isolation voltage	Verified by one of the following dielectric tests: 1200V AC for 2 s or 1697V DC for 2 s, output point to bus 75V DC working voltage (IEC Class 2 reinforced insulation)
Weight, approx.	230 g (0.51 lb)
Dimensions (HxWxD), approx.	118 x 35 x 87 mm (4.65 x 1.38 x 3.43 in.) Height with mounting tabs 138 mm (5.43 in.)
Slot width	1
Module location	DIN rail or panel mount
Power supply	1769-PA2, 1769-PB2, 1769-PA4, 1769-PB4
Power supply distance rating	8 modules

Technical Specifications - 1769-OB32T

Attribute	1769-OB32T
Terminal screw torque	0.68 N•m (6 lb•in)
Retaining screw torque	0.46 N•m (4.1 lb•in)
Wire size	(22...14 AWG) solid (22...16 AWG) stranded
Wire type	Cu-90 °C (194 °F)
Replacement connector	1746-N3 (1 connector, 40 terminals)
Vendor ID code	1
Product type code	7
Product code	79
Enclosure type rating	None (open style)

(1) To limit the effects of leakage current through solid state outputs, a loading resistor can be connected in parallel with your load. Use a 5.6 kΩ, 1/2 W resistor for transistor outputs, 24V DC operation.

(2) Use a 1N4004 diode reverse-wired across the load for transistor outputs switching 24V DC inductive loads.

Certifications - 1769-OB32T

Certification ⁽¹⁾	1769-OB32T
c-UL	C-UL certified (under CSA C22.2 No. 142) UL 508 listed Class I, Division 2 Group A,B,C,D Hazardous Locations (UL 1604, C-UL under CSA C22.2 No. 213)
CE	CE compliant for all applicable directives

(1) When marked. See the Product Certification link at <http://www.ab.com> for Declarations of Conformity, Certificates, and other certification details.

1769-OF2

Compact voltage/current output analog module

1769-OF2

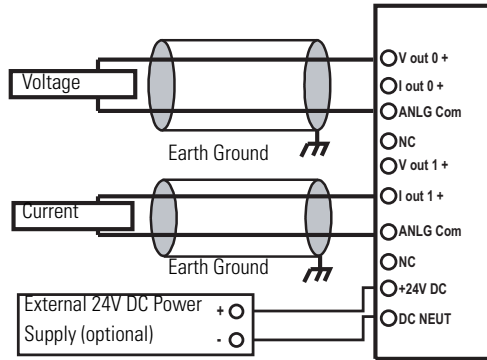

The external power supply must be rated Class 2, with a 24V DC range of 20.4...26.4V DC and 60 mA minimum. Series B and later modules support this option.

Technical Specifications - 1769-OF2

Attribute	1769-OF2
Outputs	2 single-ended
Output range	±10V 0...10V 0...5V 1...5V 0...20 mA 4...20 mA
Full scale range ⁽¹⁾	±10.5V -0.5...10.5V -0.5...5.25V 0.5...5.25V 0...21 mA 3.2...21 mA
Resolution	14 bits (unipolar) 14 bits plus sign (bipolar) ±10V DC: sign + 14 bits, 0.64 mV 0...10V DC: sign + 13 bits, 0.64 mV 0...5V DC: sign + 14 bits, 0.64 mV 1...5V DC: sign + 14 bits, 1.28 μA 0...20 mA: sign + 13 bits, 0.64 mV 4...20 mA: sign + 14 bits, 1.28 μA
Current draw @ 5.1V	120 mA
Current draw @ 24V	120 mA
Converter type	Delta Sigma
Heat dissipation, max	2.63 W
Conversion rate (all channels), max	2.5 ms
Step response to 63% ⁽²⁾	2.9 ms
Current load on voltage output, max	10 mA
Resistive load on current output	0...500 Ω (includes wire resistance)
Load range on voltage output	> 1 kΩ @ 10V DC
Inductive load (current outputs), max	0.1 mH

Technical Specifications - 1769-OF2

Attribute	1769-OF2
Capacitive load (voltage outputs), max	1 μ F
Field calibration	None required
Accuracy ⁽³⁾	Voltage: $\pm 0.5\%$ full scale @ 25 °C (77 °F) Current: $\pm 0.35\%$ full scale @ 25 °C (77 °F)
Accuracy drift with temperature	Voltage: $\pm 0.0086\%$ per °C Current: $\pm 0.0058\%$ per °C
Output ripple ⁽⁴⁾	$\pm 0.05\%$ @ 0...50 kHz
Nonlinearity	$\pm 0.05\%$
Repeatability ⁽⁵⁾	$\pm 0.05\%$
Module error	Voltage: $\pm 0.8\%$ Current: $\pm 0.55\%$
Offset error	$\pm 0.05\%$
Output impedance	15 Ω
Open and short-circuit protection	Yes
Short-circuit protection, max	21 mA
Output overvoltage protection	Yes
Time to detect open wire condition (current mode)	10 ms, typical 13.5 ms, max
Output response at system powerup and power down	± 5 V DC spike for < 5 ms
Rated working voltage ⁽⁶⁾	30V AC/30V DC
Isolation voltage	500V AC or 710V DC for 1 min (qualification test), output group to bus 30V AC/30V DC working voltage (IEC Class 2 reinforced insulation)
Weight, approx.	300 g (0.65 lb)
Dimensions (HxWxD), approx.	118 x 35 x 87 mm (4.65 x 1.38 x 3.43 in.) Height with mounting tabs 138 mm (5.43 in.)
Slot width	1
Module location	DIN rail or panel mount
Power supply	1769-PA2, 1769-PB2, 1769-PA4, 1769-PB4
Optional 24V DC Class 2 power supply voltage range ⁽⁷⁾	20.4...26.4V DC
Power supply distance rating	8 modules
Terminal screw torque	0.68 N•m (6 lb•in)
Retaining screw torque	0.46 N•m (4.1 lb•in)
Wire size	(22...14 AWG) solid (22...16 AWG) stranded
Wire type	Cu-90 °C (194 °F)
Replacement terminal block	1769-RTBN18 (1 per kit)
Replacement door label	1769-RL2 (2 per kit)
Replacement door	1769-RD (2 per kit)
Vendor ID code	1

Technical Specifications - 1769-OF2

Attribute	1769-OF2
Product type code	10
Product code	32
Enclosure type rating	None (open style)

(1) The over- or under-range flag will come on when the normal operating range (over/under) is exceeded. The module will continue to convert the analog input up to the maximum full scale range. The flag automatically resets when within the normal operating range.

(2) Step response is the period of time between when the D/A converter was instructed to go from minimum to full range until the device is at 63% of full range.

(3) Includes offset, gain, nonlinearity, and repeatability error terms.

(4) Output ripple is the amount a fixed output varies with time, assuming a constant load and temperature.

(5) Repeatability is the ability of the input module to register the same reading in successive measurements for the same input signal.

(6) Rated working voltage is the maximum continuous voltage that can be applied at the input terminal, including the input signal and the value that floats above ground potential (for example, 10V DC input signal and 20V DC potential above ground).

(7) If the optional 24V DC Class 2 power supply is used, the 24V DC current draw from the bus is 0 mA.

Certifications - 1769-OF2

Certification ⁽¹⁾	1769-OF2
c-UL	C-UL certified (under CSA C22.2 No. 142) UL 508 listed Class I, Division 2 Group A,B,C,D Hazardous Locations (UL 1604, C-UL under CSA C22.2 No. 213)
CE	CE compliant for all applicable directives

⁽¹⁾ When marked. See the Product Certification link at <http://www.ab.com> for Declarations of Conformity, Certificates, and other certification details.

1769-OF4

Compact voltage/current output analog module

Simplified Schematic

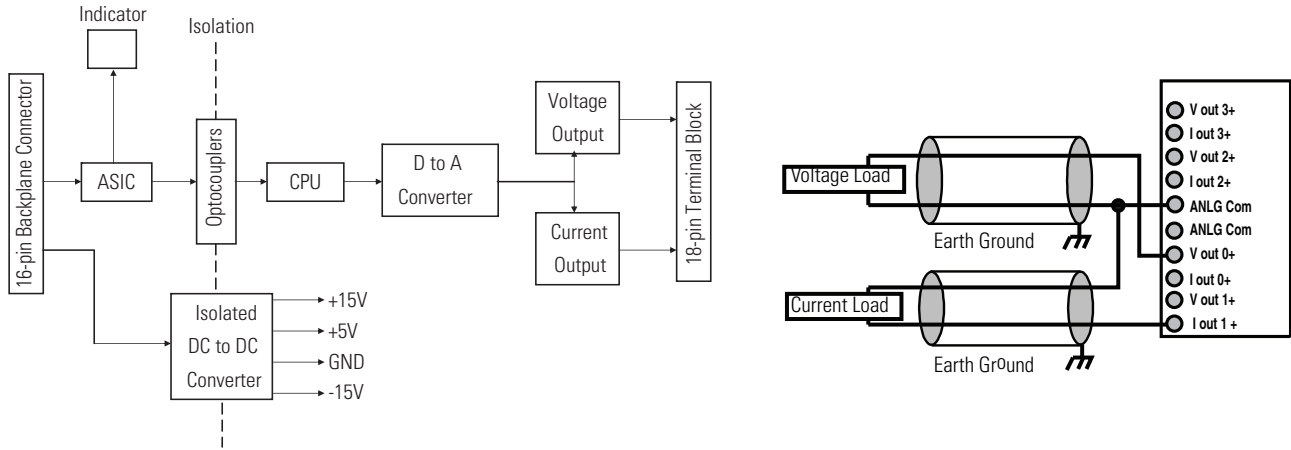

Technical Specifications - 1769-OF4

Attribute	1769-OF4
Outputs	4 single-ended
Output range	±10V 0...10V 0...5V 1...5V 0...20 mA 4...20 mA
Full scale range ⁽¹⁾	±10.5V -0.5...10.5V -0.5...5.25V 0.5...5.25V 0...21 mA 3.2...21 mA
Resolution	15 bits plus sign unipolar and bipolar
Current draw @ 5.1V	120 mA
Current draw @ 24V	170 mA
Heat dissipation, max	2.86 W
Conversion rate (all channels), max	Interrupts not enabled: 2.5 ms Interrupts enabled: 3.8 ms
Step response to 63% ⁽²⁾	2.9 ms
Resistive load	Current: 0...600 Ω (includes wire resistance) Voltage: 1 KΩ or greater
Inductive load, max	0.1 mH (current load) 1.0 μF (voltage load)
Field calibration	None required
Accuracy ⁽³⁾	0.5% full scale at 25 °C (77 °F)
Accuracy drift with temperature	±0.0086% of full scale per °C
Output ripple ⁽⁴⁾	±0.05% @ 0...50 kHz
Nonlinearity	±0.05%
Repeatability ⁽⁵⁾	±0.05%

Technical Specifications - 1769-OF4

Attribute	1769-OF4
Module error 0...60 °C (32...140 °F)	+/-0.8% of full scale
Output impedance	Voltage output: < 1 Ω Current output: > 1 M Ω
Open and short-circuit protection	Yes
Short-circuit protection, max	40 mA
Output overvoltage protection	Yes
Output response at system power up and power down	2.5...-1.0V DC spike for < 15 ms
Rated working voltage ⁽⁶⁾	30V AC/30V DC
Isolation voltage	510V AC or 720V DC for 1 minute (qualification test), output group to bus 30V AC/30V DC working voltage (IEC Class 2 reinforced insulation)
Weight, approx.	280 g (0.61 lb)
Dimensions (HxWxD), approx.	118 x 35 x 87 mm (4.65 x 1.38 x 3.43 in.) Height with mounting tabs 138 mm (5.43 in.)
Slot width	1
Module location	DIN rail or panel mount
Power supply	1769-PA2, 1769-PB2, 1769-PA4, 1769-PB4
Optional 24V DC Class 2 power supply voltage range ⁽⁷⁾	20.4...26.4V DC
Power supply distance rating	8 modules
Terminal screw torque	0.68 N•m (6 lb•in)
Retaining screw torque	0.46 N•m (4.1 lb•in)
Wire size	(22...14 AWG) solid (22...16 AWG) stranded
Wire type	Cu-90 °C (194 °F)
Replacement terminal block	1769-RTBN18 (1 per kit)
Replacement door label	1769-RL2 (2 per kit)
Replacement door	1769-RD (2 per kit)
Vendor ID code	1
Product type code	10
Product code	48
Input words	5
Output words	5
Configuration words	32
Enclosure type rating	None (open style)

⁽¹⁾ The over- or under-range flag will come on when the normal operating range (over/under) is exceeded. The module will continue to convert the analog input up to the maximum full scale range. The flag automatically resets when within the normal operating range.

⁽²⁾ Step response is the period of time between when the D/A converter was instructed to go from minimum to full range until the device is at 63% of full range.

⁽³⁾ Includes offset, gain, drift, nonlinearity, and repeatability error terms.

- (4) Output ripple is the amount a fixed output varies with time, assuming a constant load and temperature.
- (5) Repeatability is the ability of the output module to reproduce output readings when the same controller value is applied to it consecutively, under the same conditions and in the same direction.
- (6) Rated working voltage is the maximum continuous voltage that can be applied at the input terminal, including the input signal and the value that floats above ground potential (for example, 10V DC input signal and 20V DC potential above ground).
- (7) If the optional 24V DC Class 2 power supply is used, the 24V DC current draw from the bus is 0 mA.

Certifications - 1769-OF4

Certification ⁽¹⁾	1769-OF4
c-UL	C-UL certified (under CSA C22.2 No. 142) UL 508 listed Class I, Division 2 Group A,B,C,D Hazardous Locations (UL 1604, C-UL under CSA C22.2 No. 213)
CE	CE compliant for all applicable directives

⁽¹⁾ When marked. See the Product Certification link at <http://www.ab.com> for Declarations of Conformity, Certificates, and other certification details.

1769-OF4CI

Compact current output, individually isolated analog module

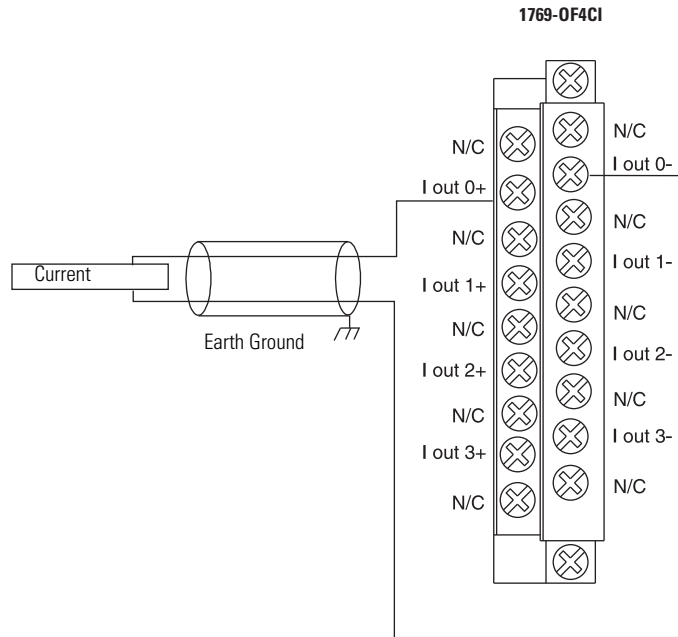

Technical Specifications - 1769-OF4CI

Attribute	1769-OF4CI
Outputs	4 differential, individually isolated
Output range	0...20 mA 4...20 mA
Full scale range ⁽¹⁾	0...21 mA 3.2...21 mA
Resolution	16 bits (unipolar) 0...20 mA: 15.91 bits, 0.323 μ A/bit 4...20 mA: 15.59 bits, 0.323 μ A/bit
Current draw @ 5.1V	145 mA
Current draw @ 24V	140 mA
Heat dissipation, max	2.68 W
Conversion rate (all channels), max	110 ms
Step response to 63% ⁽²⁾	< 2.9 ms
Resistive load on current output	0...500 Ω (includes wire resistance)
Inductive load (current outputs), max	0.1 mH
Field calibration	None required
Accuracy ⁽³⁾	\pm 0.35% full scale @ 25 $^{\circ}$ C (77 $^{\circ}$ F)
Accuracy drift with temperature	\pm 0.0058% per $^{\circ}$ C
Output ripple ⁽⁴⁾	\pm 0.05% @ 0...50 kHz
Nonlinearity	\pm 0.05%

Technical Specifications - 1769-OF4CI

Attribute	1769-OF4CI
Repeatability ⁽⁵⁾	±0.05%
Module error	±0.55%
Output impedance	< 1 MΩ
Open and short-circuit protection	Yes
Short-circuit protection, max	21 mA
Output overvoltage protection	Yes
Output response at system powerup and power down	No current glitch
Rated working voltage ⁽⁶⁾	30V AC/30V DC
Isolation voltage	500V AC or 710V DC for 1 min (qualification test), output group to bus 30V AC/30V DC working voltage (IEC Class 2 reinforced insulation)
Weight, approx.	270 g (0.60 lb)
Dimensions (HxWxD), approx.	118 x 35 x 87 mm (4.65 x 1.38 x 3.43 in.) Height with mounting tabs 138 mm (5.43 in.)
Slot width	1
Module location	DIN rail or panel mount
Power supply	1769-PA2, 1769-PB2, 1769-PA4, 1769-PB4
Power supply distance rating	8 modules
Terminal screw torque	0.68 N•m (6 lb•in)
Retaining screw torque	0.46 N•m (4.1 lb•in)
Wire size	(22...14 AWG) solid (22...16 AWG) stranded
Wire type	Cu-90 °C (194 °F)
Replacement terminal block	1769-RTBN18 (1 per kit)
Replacement door label	1769-RL2 (2 per kit)
Replacement door	1769-RD (2 per kit)
Vendor ID code	1
Product type code	10
Product code	45
Input words	6
Output words	5
Configuration words	32
Enclosure type rating	None (open style)

(1) The over- or under-range flag will come on when the normal operating range (over/under) is exceeded. The module will continue to convert the analog input up to the maximum full scale range. The flag automatically resets when within the normal operating range.

(2) Step response is the period of time between when the D/A converter was instructed to go from minimum to full range until the device is at 63% of full range.

(3) Includes offset, gain, nonlinearity, and repeatability error terms.

(4) Output ripple is the amount a fixed output varies with time, assuming a constant load and temperature.

1769 Compact I/O Modules Specifications

(5) Repeatability is the ability of the input module to register the same reading in successive measurements for the same input signal.

(6) Rated working voltage is the maximum continuous voltage that can be applied at the input terminal, including the input signal and the value that floats above ground potential (for example, 10V DC input signal and 20V DC potential above ground).

Certifications - 1769-OF4CI

Certification ⁽¹⁾	1769-OF4CI
c-UL	C-UL certified (under CSA C22.2 No. 142) UL 508 listed Class I, Division 2 Group A,B,C,D Hazardous Locations (UL 1604, C-UL under CSA C22.2 No. 213)
CE	CE compliant for all applicable directives

(1) When marked. See the Product Certification link at <http://www.ab.com> for Declarations of Conformity, Certificates, and other certification details.

1769-OF4VI

Compact voltage output, individually isolated analog module

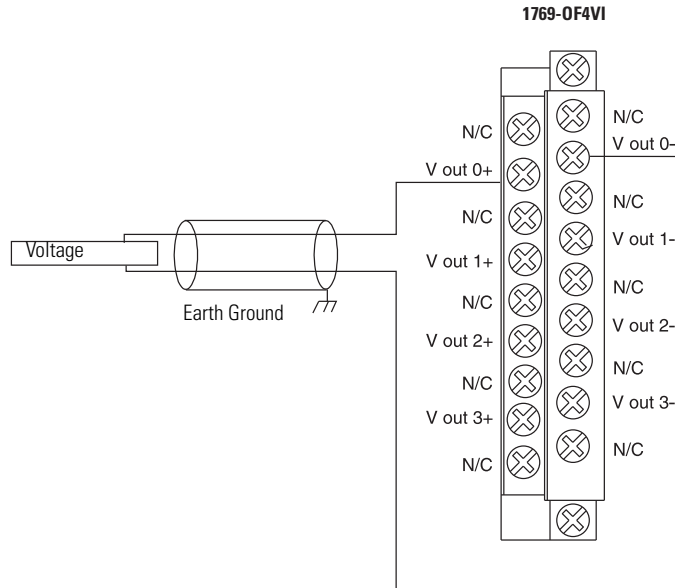

Technical Specifications - 1769-OF4VI

Attribute	1769-OF4VI
Outputs	4 differential, individually isolated
Output range	±10V 0...10V 0...5V 1...5V
Full scale range ⁽¹⁾	±10.5V -0.5...10.5V -0.5...5.25V 0.5...5.25V
Resolution	15 bits plus sign (bipolar) ±10V DC: 15.89 bits, 330 μV/bit 0...10V DC: 14.89 bits, 330 μV/bit 0...5V DC: 13.89 bits, 330 μV/bit 1...5V DC: 13.57 bits, 330 μV/bit
Current draw @ 5.1V	145 mA
Current draw @ 24V	75 mA
Heat dissipation, max	2.0 W
Conversion rate (all channels), max	120 ms
Step response to 63% ⁽²⁾	< 2.9 ms
Load output current, max	5 mA
Load range output	≥ 2 kΩ
Capacitive load (voltage outputs), max	1 μF
Field calibration	None required
Accuracy ⁽³⁾	±0.5% full scale @ 25 °C (77 °F)
Accuracy drift with temperature	±0.0086% per °C
Output ripple ⁽⁴⁾	±0.05% @ 0...50 kHz

Technical Specifications - 1769-OF4VI

Attribute	1769-OF4VI
Nonlinearity	±0.05%
Repeatability ⁽⁵⁾	±0.05%
Module error	±0.8%
Output impedance	< 1 Ω
Open and short-circuit protection	Yes
Short-circuit protection, max	35 mA typical 42 mA, max
Output overvoltage protection	Yes
Output response at system powerup and power down	Powerup: ±1.2V DC spike for < 0.4 ms Power down: ±1.2V DC spike for 21 ms
Rated working voltage ⁽⁶⁾	30V AC/30V DC
Isolation voltage	500V AC or 710V DC for 1 min (qualification test), output group to bus 30V AC/30V DC working voltage (IEC Class 2 reinforced insulation)
Weight, approx.	300 g (0.65 lb)
Dimensions (HxWxD), approx.	118 x 35 x 87 mm (4.65 x 1.38 x 3.43 in.) Height with mounting tabs 138 mm (5.43 in.)
Slot width	1
Module location	DIN rail or panel mount
Power supply	1769-PA2, 1769-PB2, 1769-PA4, 1769-PB4
Power supply distance rating	8 modules
Terminal screw torque	0.68 N•m (6 lb•in)
Retaining screw torque	0.46 N•m (4.1 lb•in)
Wire size	(22...14 AWG) solid (22...16 AWG) stranded
Wire type	Cu-90 °C (194 °F)
Replacement terminal block	1769-RTBN18 (1 per kit)
Replacement door label	1769-RL2 (2 per kit)
Replacement door	1769-RD (2 per kit)
Vendor ID code	1
Product type code	10
Product code	42
Input words	6
Output words	5
Configuration words	32
Enclosure type rating	None (open style)

(1) The over- or under-range flag will come on when the normal operating range (over/under) is exceeded. The module will continue to convert the analog input up to the maximum full scale range. The flag automatically resets when within the normal operating range.

(2) Step response is the period of time between when the D/A converter was instructed to go from minimum to full range until the device is at 63% of full range.

(3) Includes offset, gain, nonlinearity, and repeatability error terms.

- (4) Output ripple is the amount a fixed output varies with time, assuming a constant load and temperature.
- (5) Repeatability is the ability of the input module to register the same reading in successive measurements for the same input signal.
- (6) Rated working voltage is the maximum continuous voltage that can be applied at the input terminal, including the input signal and the value that floats above ground potential (for example, 10V DC input signal and 20V DC potential above ground).

Certifications - 1769-OF4VI

Certification⁽¹⁾	1769-OF4VI
c-UL	C-UL certified (under CSA C22.2 No. 142) UL 508 listed Class I, Division 2 Group A,B,C,D Hazardous Locations (UL 1604, C-UL under CSA C22.2 No. 213)
CE	CE compliant for all applicable directives

⁽¹⁾ When marked. See the Product Certification link at <http://www.ab.com> for Declarations of Conformity, Certificates, and other certification details.

1769-OF8C

Compact current output analog module

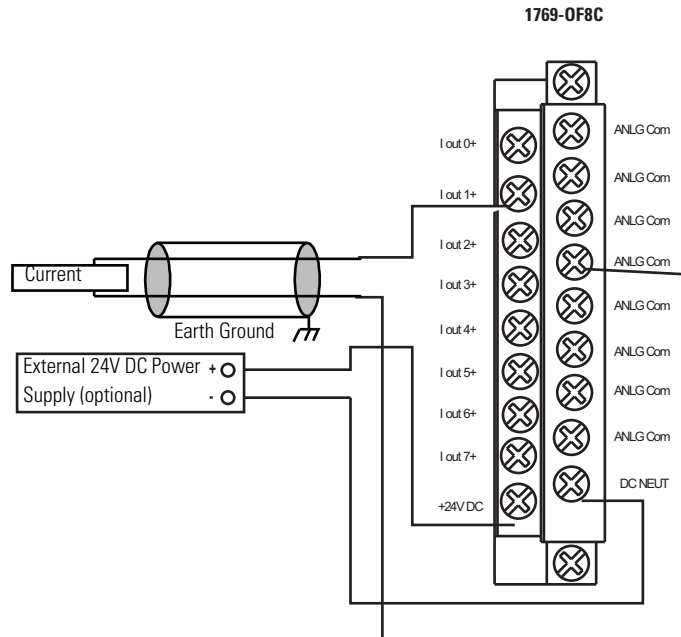

The external power supply must be rated Class 2, with a 24V DC range of 20.4...6.4V DC and 60 mA minimum. Series B and later modules support this option.

Technical Specifications - 1769-OF8C

Attribute	1769-OF8C
Outputs	8 single-ended
Output range	0...20 mA 4...20 mA
Full scale range ⁽¹⁾	0...21 mA 3.2...21 mA
Resolution	16 bits (unipolar) 0...20 mA: 15.91 bits, 0.323 μ A/bit 4...20 mA: 15.59 bits, 0.323 μ A/bit
Current draw @ 5.1V	145 mA
Current draw @ 24V	140 mA
Heat dissipation, max	2.69 W
Conversion rate (all channels), max	5 ms
Step response to 63% ⁽²⁾	< 2.9 ms
Resistive load on current output	0...500 Ω (includes wire resistance)
Inductive load (current outputs), max	0.1 mH
Field calibration	None required
Accuracy ⁽³⁾	\pm 0.35% full scale @ 25 °C (77 °F)
Accuracy drift with temperature	\pm 0.0058% per °C
Output ripple ⁽⁴⁾	\pm 0.05% @ 0...50 kHz

Technical Specifications - 1769-OF8C

Attribute	1769-OF8C
Nonlinearity	±0.05%
Repeatability ⁽⁵⁾	±0.05%
Module error	±0.55%
Offset error	±0.05%
Output impedance	> 1 MΩ
Open and short-circuit protection	Yes
Short-circuit protection, max	21 mA
Output overvoltage protection	Yes
Output response at system powerup and power down	±0.5V DC spike for < 5 ms
Rated working voltage ⁽⁶⁾	30V AC/30V DC
Isolation voltage	500V AC or 710V DC for 1 min (qualification test), output group to bus 30V AC/30V DC working voltage (IEC Class 2 reinforced insulation)
Weight, approx.	281 g (0.62 lb)
Dimensions (HxWxD), approx.	118 x 35 x 87 mm (4.65 x 1.38 x 3.43 in.) Height with mounting tabs 138 mm (5.43 in.)
Slot width	1
Module location	DIN rail or panel mount
Power supply	1769-PA2, 1769-PB2, 1769-PA4, 1769-PB4
Optional 24V DC Class 2 power supply voltage range ⁽⁷⁾	20.4...26.4V DC
Power supply distance rating	8 modules
Terminal screw torque	0.68 N•m (6 lb•in)
Retaining screw torque	0.46 N•m (4.1 lb•in)
Wire size	(22...14 AWG) solid (22...16 AWG) stranded
Wire type	Cu-90 °C (194 °F)
Replacement terminal block	1769-RTBN18 (1 per kit)
Replacement door label	1769-RL2 (2 per kit)
Replacement door	1769-RD (2 per kit)
Vendor ID code	1
Product type code	10
Product code	40
Input words	11
Output words	9
Configuration words	64
Enclosure type rating	None (open style)

⁽¹⁾ The over- or under-range flag will come on when the normal operating range (over/under) is exceeded. The module will continue to convert the analog input up to the maximum full scale range. The flag automatically resets when within the normal operating range.

⁽²⁾ Step response is the period of time between when the D/A converter was instructed to go from minimum to full range until the device is at 63% of full range.

- (3) Includes offset, gain, nonlinearity, and repeatability error terms.
- (4) Output ripple is the amount a fixed output varies with time, assuming a constant load and temperature.
- (5) Repeatability is the ability of the input module to register the same reading in successive measurements for the same input signal.
- (6) Rated working voltage is the maximum continuous voltage that can be applied at the input terminal, including the input signal and the value that floats above ground potential (for example, 10V DC input signal and 20V DC potential above ground).
- (7) If the optional 24V DC Class 2 power supply is used, the 24V DC current draw from the bus is 0 mA.

Certifications - 1769-OF8C

Certification ⁽¹⁾	1769-OF8C
c-UL	C-UL certified (under CSA C22.2 No. 142) UL 508 listed Class I, Division 2 Group A,B,C,D Hazardous Locations (UL 1604, C-UL under CSA C22.2 No. 213)
CE	CE compliant for all applicable directives

⁽¹⁾ When marked. See the Product Certification link at <http://www.ab.com> for Declarations of Conformity, Certificates, and other certification details.

1769-OF8V

Compact voltage output analog module

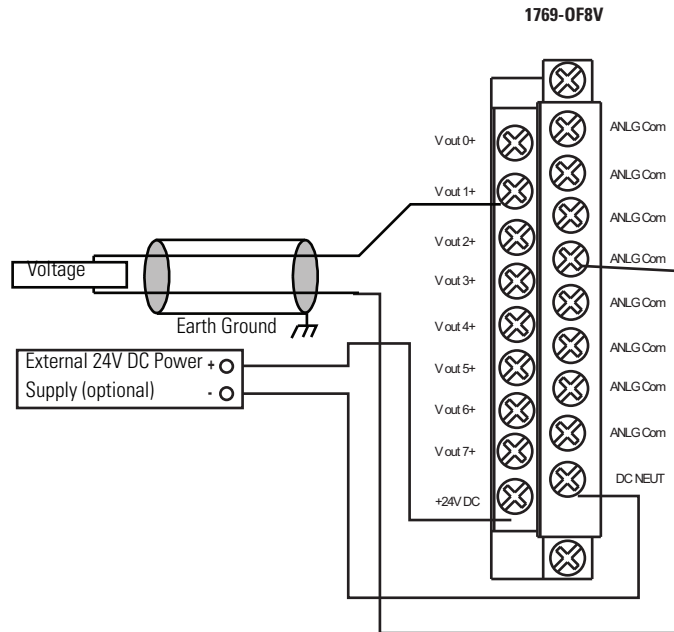

The external power supply must be rated Class 2, with a 24V DC range of 20.4...6.4V DC and 60 mA minimum. Series B and later modules support this option.

Technical Specifications - 1769-OF8V

Attribute	1769-OF8V
Outputs	8 single-ended
Output range	±10V 0...10V 0...5V 1...5V
Full scale range ⁽¹⁾	±10.5V -0.5...10.5V -0.5...5.25V 0.5...5.25V
Resolution	16 bits plus sign (bipolar) ±10V DC: 15.89 bits, 330 μV/bit 0...10V DC: 14.89 bits, 330 μV/bit 0...5V DC: 13.89 bits, 330 μV/bit 1...5V DC: 13.57 bits, 330 μV/bit
Current draw @ 5.1V	145 mA
Current draw @ 24V	125 mA
Heat dissipation, max	2.16 W
Conversion rate (all channels), max	5.0 ms
Step response to 63% ⁽²⁾	< 2.9 ms
Load output current, max	10 mA
Load range output	> 1 kΩ
Capacitive load (voltage outputs), max	1 μF

Technical Specifications - 1769-OF8V

Attribute	1769-OF8V
Field calibration	None required
Accuracy ⁽³⁾	±0.5% full scale @ 25 °C (77 °F)
Accuracy drift with temperature	±0.0086% per °C
Output ripple ⁽⁴⁾	±0.05% @ 0...50 kHz
Nonlinearity	±0.05%
Repeatability ⁽⁵⁾	±0.05%
Module error	±0.8%
Offset error	±0.05%
Output impedance	< 1 Ω
Open and short-circuit protection	Yes
Short-circuit protection, max	30 mA
Output overvoltage protection	Yes
Output response at system powerup and power down	± 0.5V DC spike for < 5 ms
Rated working voltage ⁽⁶⁾	30V AC/30V DC
Isolation voltage	500V AC or 710V DC for 1 min (qualification test), output group to bus 30V AC/30V DC working voltage (IEC Class 2 reinforced insulation)
Weight, approx.	263 g (0.58 lb)
Dimensions (HxWxD), approx.	118 x 35 x 87 mm (4.65 x 1.38 x 3.43 in.) Height with mounting tabs 138 mm (5.43 in.)
Slot width	1
Module location	DIN rail or panel mount
Power supply	1769-PA2, 1769-PB2, 1769-PA4, 1769-PB4
Optional 24V DC Class 2 power supply voltage range ⁽⁷⁾	20.4...26.4V DC
Power supply distance rating	8 modules
Terminal screw torque	0.68 N•m (6 lb•in)
Retaining screw torque	0.46 N•m (4.1 lb•in)
Wire size	(22...14 AWG) solid (22...16 AWG) stranded
Wire type	Cu-90 °C (194 °F)
Replacement terminal block	1769-RTBN18 (1 per kit)
Replacement door label	1769-RL2 (2 per kit)
Replacement door	1769-RD (2 per kit)
Vendor ID code	1
Product type code	10
Product code	39
Input words	11
Output words	9
Configuration words	64
Enclosure type rating	None (open style)

- (1) The over- or under-range flag will come on when the normal operating range (over/under) is exceeded. The module will continue to convert the analog input up to the maximum full scale range. The flag automatically resets when within the normal operating range.
- (2) Step response is the period of time between when the D/A converter was instructed to go from minimum to full range until the device is at 63% of full range.
- (3) Includes offset, gain, nonlinearity, and repeatability error terms.
- (4) Output ripple is the amount a fixed output varies with time, assuming a constant load and temperature.
- (5) Repeatability is the ability of the input module to register the same reading in successive measurements for the same input signal.
- (6) Rated working voltage is the maximum continuous voltage that can be applied at the input terminal, including the input signal and the value that floats above ground potential (for example, 10V DC input signal and 20V DC potential above ground).
- (7) If the optional 24V DC Class 2 power supply is used, the 24V DC current draw from the bus is 0 mA.

Certifications - 1769-OF8V

Certification ⁽¹⁾	1769-OF8V
c-UL	C-UL certified (under CSA C22.2 No. 142) UL 508 listed Class I, Division 2 Group A,B,C,D Hazardous Locations (UL 1604, C-UL under CSA C22.2 No. 213)
CE	CE compliant for all applicable directives

⁽¹⁾ When marked. See the Product Certification link at <http://www.ab.com> for Declarations of Conformity, Certificates, and other certification details.

1769-0G16

Compact TTL output module

Simplified Output Circuit Diagram

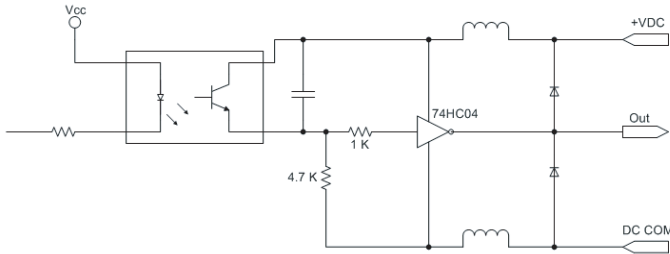

- Use Belden 8761, or equivalent, shielded wire.
- Do not connect more than two wires to any single terminal.
- DC power cable and I/O cables should not exceed 10 m (30 ft).
- The capacitors shown above must be 0.01 μ F and rated for 2000V min.
- User power supply must be rated Class 2 with a 5V DC range of 4.5...5.5V DC.

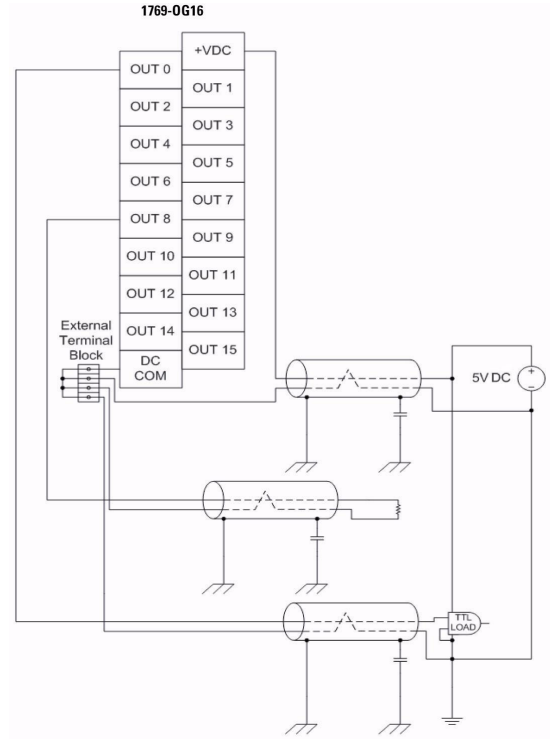

Low to True Format - 1769-0G16

- 0...0.4V DC = Output guaranteed to be in on-state
- 0.4...4.5V DC = Output state not guaranteed
- 4.5...5.5V DC = Output guaranteed to be in off-state

Technical Specifications - 1769-0G16

Attribute	1769-0G16
Outputs	16
Voltage category	5V DC TTL (Low=True) ⁽¹⁾
Operating voltage range	4.5...5.5V DC 50 mV peak-to-peak ripple max
Output delay, off to on	0.25 ms
Output delay, on to off	0.50 ms
Current draw @ 5.1V	200 mA
Heat dissipation, max	1.2 W
Off-state voltage, typical	4.5...5.5V DC
On-state voltage	0...0.4V DC
Load current, min	0.15 mA

Technical Specifications - 1769-OG16

Attribute	1769-OG16
Current per point, max	24 mA
Isolation voltage	Verified by one of the following dielectric tests: 1200V AC for 2 s or 1697V DC for 2 s, output point to bus 75V DC working voltage (IEC Class 2 reinforced insulation)
Weight, approx.	250 g (0.55 lb)
Dimensions (HxWxD), approx.	118 x 35 x 87 mm (4.65 x 1.38 x 3.43 in.) Height with mounting tabs 138 mm (5.43 in.)
Slot width	1
Module location	DIN rail or panel mount
Power supply	1769-PA2, 1769-PB2, 1769-PA4, 1769-PB4
Power supply distance rating	8 modules
Terminal screw torque	0.68 N•m (6 lb•in)
Retaining screw torque	0.46 N•m (4.1 lb•in)
Wire size	(22...14 AWG) solid (22...16 AWG) stranded
Wire type	Cu-90 °C (194 °F)
Vendor ID code	1
Product type code	7
Product code	78
Input words	1
Output words	1
Configuration words	5
Enclosure type rating	None (open-style)

⁽¹⁾ TTL inputs are inverted (-0.2 to +0.8 = low voltage = True = On.) Use a NOT instruction in your program to convert to traditional True = High logic.

Certifications - 1769-OG16

Certification ⁽¹⁾	1769-OG16
c-UL	C-UL certified (under CSA C22.2 No. 142) UL 508 listed Class I, Division 2 Group A,B,C,D Hazardous Locations (UL 1604, C-UL under CSA C22.2 No. 213)
CE	CE compliant for all applicable directives

⁽¹⁾ When marked. See the Product Certification link at <http://www.ab.com> for Declarations of Conformity, Certificates, and other certification details.

1769-0V16

Compact solid state 24V DC sink output module

Simplified Output Circuit Diagram

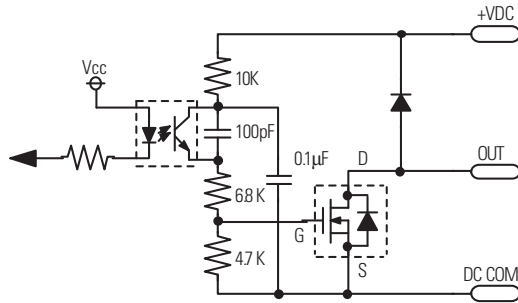

1769-0V16

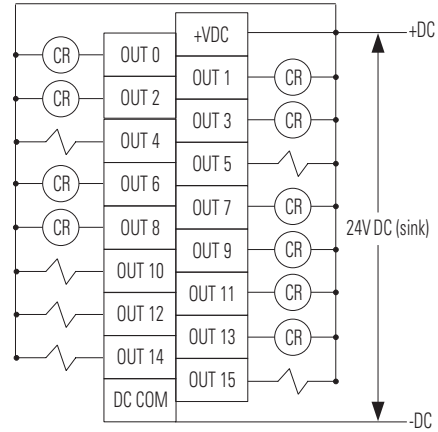

Technical Specifications - 1769-0V16

Attribute	1769-0V16
Outputs	16 (16 points/group)
Voltage category	24V DC sink
Operating voltage range	20.4...26.4V DC
Output delay, on	0.1 ms
Output delay, off	1.0 ms
Current draw @ 5.1V	200 mA
Heat dissipation, max	2.06 W
Off-state leakage current, max ⁽¹⁾	1.0 mA @ 26.4V DC
On-state current, min	1.0 mA
On-state voltage drop, max	1.0V DC @ 1 A
Current per point, max	0.5 A @ 60 °C (140 °F) 1.0 A @ 30 °C (86 °F)
Current per module, max	4.0 A @ 60 °C (140 °F) 8.0 A @ 30 °C (86 °F)
Surge current ⁽²⁾	2.0 A for 10 ms, repeatable every 2 s
Isolation voltage	Verified by one of the following dielectric tests: 1200V AC for 1 s or 1697V DC for 1 s, output point to bus 75V DC working voltage (IEC Class 2 reinforced insulation)
Weight, approx.	280 g (0.61 lb)
Dimensions (HxWxD), approx.	118 x 35 x 87 mm (4.65 x 1.38 x 3.43 in.) Height with mounting tabs 138 mm (5.43 in.)
Slot width	1
Module location	DIN rail or panel mount
Power supply	1769-PA2, 1769-PB2, 1769-PA4, 1769-PB4
Power supply distance rating	8 modules

Technical Specifications - 1769-OV16

Attribute	1769-OV16
Terminal screw torque	0.68 N•m (6 lb•in)
Retaining screw torque	0.46 N•m (4.1 lb•in)
Wire size	(22...14 AWG) solid (22...16 AWG) stranded
Wire type	Cu-90 °C (194 °F)
Replacement terminal block	1769-RTBN18 (1 per kit)
Replacement door label	1769-RL1 (2 per kit)
Replacement door	1769-RD (2 per kit)
Vendor ID code	1
Product type code	7
Product code	72
Enclosure type rating	None (open style)

⁽¹⁾ To limit the effects of leakage current through solid state outputs, a loading resistor can be connected in parallel with your load. Use a 5.6 k Ω , 1/2 W resistor for transistor outputs, 24V DC operation.

⁽²⁾ Use a 1N4004 diode reverse-wired across the load for transistor outputs switching 24V DC inductive loads.

Temperature Derating - 1769-OV16

1769-OV16 Maximum Amperes per Point versus Temperature

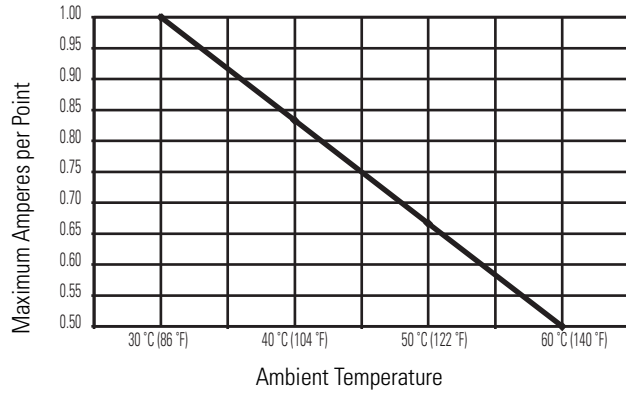

1769-OV16 Maximum Amperes per Module versus Temperature

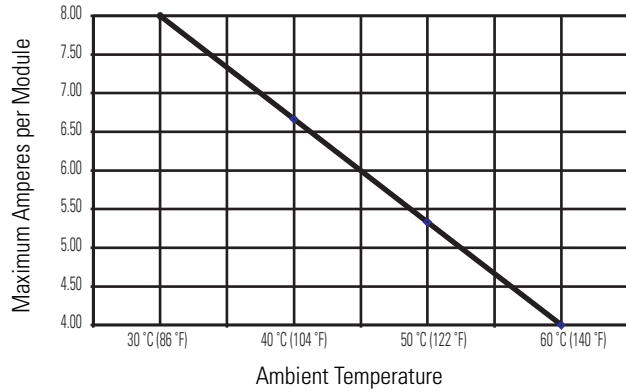

Certifications - 1769-OV16

Certification ⁽¹⁾	1769-OV16
c-UL	C-UL certified (under CSA C22.2 No. 142) UL 508 listed Class I, Division 2 Group A,B,C,D Hazardous Locations (UL 1604, C-UL under CSA C22.2 No. 213)
CE	CE compliant for all applicable directives
C-Tick	C-Tick compliant for all applicable directives

⁽¹⁾ When marked. See the Product Certification link at <http://www.ab.com> for Declarations of Conformity, Certificates, and other certification details.

1769-OV32T

Compact solid state 24V DC sink, terminated output module

Simplified Output Circuit Diagram

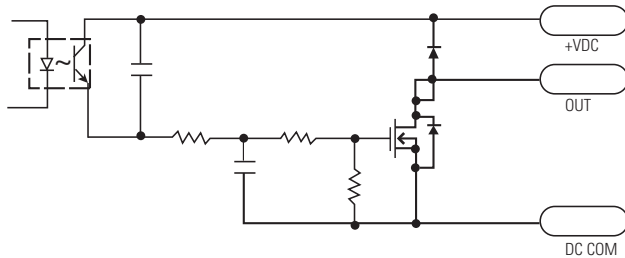

1769-OV32T

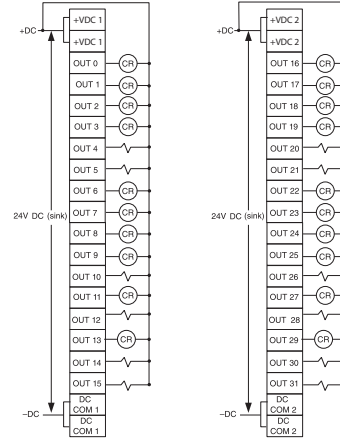

Technical Specifications - 1769-OV32T

Attribute	1769-OV32T
Outputs	32 terminated (16 points/group)
Voltage category	24V DC sink
Operating voltage range	10.2...26.4V DC
Output delay, on	< 16V, 1.5 ms >= 16V, 1.0 ms
Output delay, off	4.0 ms
Current draw @ 5.1V	300 mA
Heat dissipation, max	4.5 W
Off-state leakage current, max ⁽¹⁾	1.0 mA @ 26.4V DC
On-state current, min	1.0 mA
On-state voltage drop, max	0.3V DC @ 0.5 A
Current per point, max	0.5 A
Current per module, max	4.0 A
Surge current ⁽²⁾	2.0 A for 10 ms, repeatable every 2 s
Isolation voltage	Verified by one of the following dielectric tests: 1200V AC for 1 s or 1697V DC for 1 s, output point to bus 75V DC working voltage (IEC Class 2 reinforced insulation)
Weight, approx.	450 g (0.992 lb)
Dimensions (HxWxD), approx.	118 x 35 x 87 mm (4.65 x 1.38 x 3.43 in.) Height with mounting tabs 138 mm (5.43 in.)
Slot width	1
Module location	DIN rail or panel mount
Power supply	1769-PA2, 1769-PB2, 1769-PA4, 1769-PB4
Power supply distance rating	8 modules

Technical Specifications - 1769-OV32T

Attribute	1769-OV32T
Terminal screw torque	0.68 N•m (6 lb•in)
Retaining screw torque	0.46 N•m (4.1 lb•in)
Wire size	(22...14 AWG) solid (22...16 AWG) stranded
Wire type	Cu-90 °C (194 °F)
Replacement connector	1746-N3 (1 connector, 40 terminals)
Vendor ID code	1
Product type code	7
Product code	75
Enclosure type rating	None (open style)

(1) To limit the effects of leakage current through solid state outputs, a loading resistor can be connected in parallel with your load. Use a 5.6 k Ω , 1/2 W resistor for transistor outputs, 24V DC operation.

(2) Use a 1N4004 diode reverse-wired across the load for transistor outputs switching 24V DC inductive loads.

Certifications - 1769-OV32T

Certification ⁽¹⁾	1769-OV32T
c-UL	C-UL certified (under CSA C22.2 No. 142) UL 508 listed Class I, Division 2 Group A,B,C,D Hazardous Locations (UL 1604, C-UL under CSA C22.2 No. 213)
CE	CE compliant for all applicable directives
C-Tick	C-Tick compliant for all applicable directives

(1) When marked. See the Product Certification link at <http://www.ab.com> for Declarations of Conformity, Certificates, and other certification details.

1769-0W8

Compact AC/DC relay contact module

Simplified Output Circuit Diagram

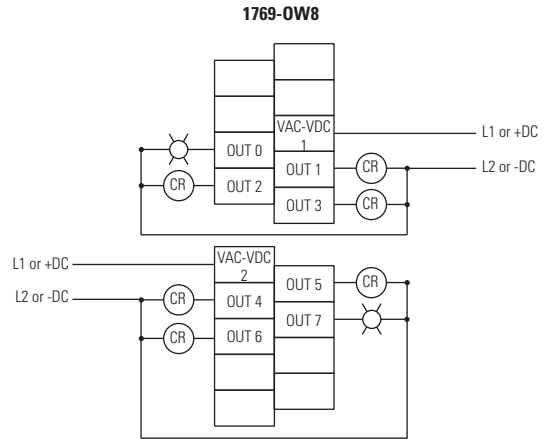
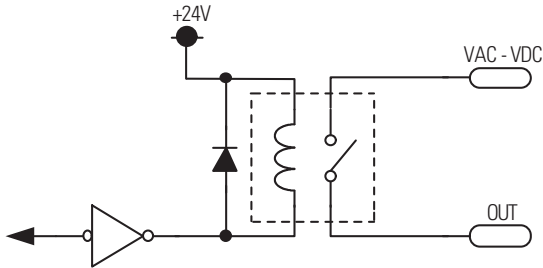

Technical Specifications - 1769-0W8

Attribute	1769-0W8
Outputs	8 normally open (4 points/group)
Operating voltage range	5...265V AC 5...125V DC
Delay, on	10 ms
Delay, off	10 ms
Current draw @ 5.1V	125 mA
Current draw @ 24V	100 mA
Heat dissipation, max	2.83 W
Off-state leakage, max	0 mA
On-state current, min	10 mA @ 5V DC
Current per point, max	2.5 A
Current per module, max	16 A
Isolation voltage	Verified by one of the following dielectric tests: 1836V AC for 1 s or 2596V DC for 1 s, output point to bus and group to group 265V AC working voltage (IEC Class 2 reinforced insulation)
Weight, approx.	280 g (0.61 lb)
Dimensions (HxWxD), approx.	118 x 35 x 87 mm (4.65 x 1.38 x 3.43 in.) Height with mounting tabs 138 mm (5.43 in.)
Slot width	1
Module location	DIN rail or panel mount
Power supply	1769-PA2, 1769-PB2, 1769-PA4, 1769-PB4
Power supply distance rating	8 modules
Terminal screw torque	0.68 N•m (6 lb•in)
Retaining screw torque	0.46 N•m (4.1 lb•in)
Wire size	(22...14 AWG) solid (22...16 AWG) stranded

Technical Specifications - 1769-OW8

Attribute	1769-OW8
Wire type	Cu-90 °C (194 °F)
Replacement terminal block	1769-RTBN10 (1 per kit)
Replacement door label	1769-RL1 (2 per kit)
Replacement door	1769-RD (2 per kit)
Vendor ID code	1
Product type code	7
Product code	86
Enclosure type rating	None (open style)

Relay Contact Ratings - 1769-OW8

Volts, max	Continuous Amps per Point, max	Amperes ⁽¹⁾		Voltamperes		NEMA ICS 2-125
		Make	Break	Make	Break	
240V AC	2.5 A	7.5 A	0.75 A	1800VA	180VA	C300
120V AC		15 A	1.5 A			
125V DC	1.0 A	0.22 A ⁽²⁾		28VA		R150
24V DC	2.0 A	1.2 A ⁽²⁾		28VA		—

⁽¹⁾ Connecting surge suppressors across your external inductive load will extend the life of the relay contacts.

⁽²⁾ For DC voltage applications, the make/break ampere rating for relay contacts can be determined by dividing 28VA by the applied DC voltage. For example, 28VA/48V DC = 0.58 A. For DC voltage applications less than 48V, the make/break ratings for relay contacts cannot exceed 2 A.

Certifications - 1769-OW8

Certification ⁽¹⁾	1769-OW8
c-UL	C-UL certified (under CSA C22.2 No. 142) UL 508 listed Class I, Division 2 Group A,B,C,D Hazardous Locations (UL 1604, C-UL under CSA C22.2 No. 213)
CE	CE compliant for all applicable directives
C-Tick	C-Tick compliant for all applicable directives

⁽¹⁾ When marked. See the Product Certification link at <http://www.ab.com> for Declarations of Conformity, Certificates, and other certification details.

1769-OW8I

Compact AC/DC individually isolated, relay contact module

Simplified Output Circuit Diagram

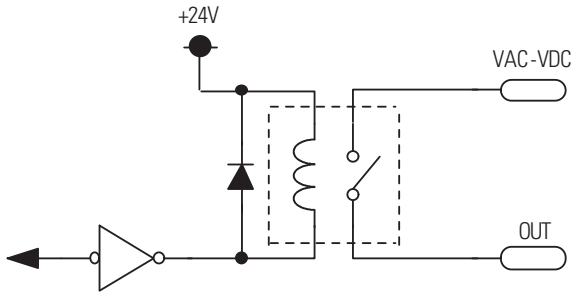

1769-OW8I

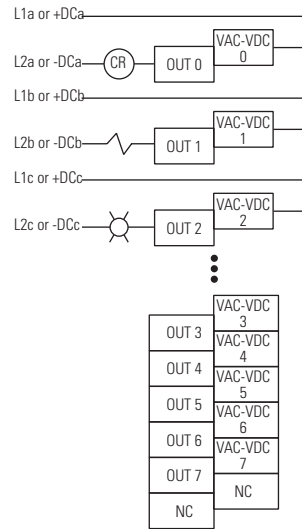

Technical Specifications - 1769-OW8I

Attribute	1769-OW8I
Outputs	8 normally open, individually isolated (4 points/group)
Operating voltage range	5...265V AC 5...125V DC
Delay, on	10 ms
Delay, off	10 ms
Current draw @ 5.1V	125 mA
Current draw @ 24V	100 mA
Heat dissipation, max	2.83 W
Off-state leakage, max	0 mA
On-state current, min	10 mA @ 5V DC
Current per point, max	2.5 A
Current per module, max	16 A
Isolation voltage	Verified by one of the following dielectric tests: 1836V AC for 1 s or 2596V DC for 1 s, output point to bus 265V AC working voltage (IEC Class 2 reinforced insulation) Verified by one of the following dielectric tests: 1836V AC for 1 s or 2596V DC for 1 s, group to group 265V AC working voltage (basic insulation) 150V AC working voltage (IEC Class 2 reinforced insulation)
Weight, approx.	290 g (0.64 lb)
Dimensions (HxWxD), approx.	118 x 35 x 87 mm (4.65 x 1.38 x 3.43 in.) Height with mounting tabs 138 mm (5.43 in.)
Slot width	1

Technical Specifications - 1769-OW8I

Attribute	1769-OW8I
Module location	DIN rail or panel mount
Power supply	1769-PA2, 1769-PB2, 1769-PA4, 1769-PB4
Power supply distance rating	8 modules
Terminal screw torque	0.68 N•m (6 lb•in)
Retaining screw torque	0.46 N•m (4.1 lb•in)
Wire size	(22...14 AWG) solid (22...16 AWG) stranded
Wire type	Cu-90 °C (194 °F)
Replacement terminal block	1769-RTBN18 (1 per kit)
Replacement door label	1769-RL1 (2 per kit)
Replacement door	1769-RD (2 per kit)
Vendor ID code	1
Product type code	7
Product code	87
Enclosure type rating	None (open style)

Relay Contact Ratings - 1769-OW8I

Volts, max	Continuous Amps per Point, max	Amperes ⁽¹⁾		Voltamperes		NEMA ICS 2-125
		Make	Break	Make	Break	
240V AC	2.5 A	7.5 A	0.75 A	1800VA	180VA	C300
120V AC		15 A	1.5 A			
125V DC	1.0 A	0.22 A ⁽²⁾		28VA		R150
24V DC	2.0 A	1.2 A ⁽²⁾		28VA		—

⁽¹⁾ Connecting surge suppressors across your external inductive load will extend the life of the relay contacts.

⁽²⁾ For DC voltage applications, the make/break ampere rating for relay contacts can be determined by dividing 28VA by the applied DC voltage. For example, 28VA/48V DC = 0.58 A. For DC voltage applications less than 48V, the make/break ratings for relay contacts cannot exceed 2 A.

Certifications - 1769-OW8I

Certification ⁽¹⁾	1769-OW8I
c-UL	C-UL certified (under CSA C22.2 No. 142) UL 508 listed Class I, Division 2 Group A,B,C,D Hazardous Locations (UL 1604, C-UL under CSA C22.2 No. 213)
CE	CE compliant for all applicable directives
C-Tick	C-Tick compliant for all applicable directives

⁽¹⁾ When marked. See the Product Certification link at <http://www.ab.com> for Declarations of Conformity, Certificates, and other certification details.

1769-OW16

Compact AC/DC relay contact module

Simplified Output Circuit Diagram

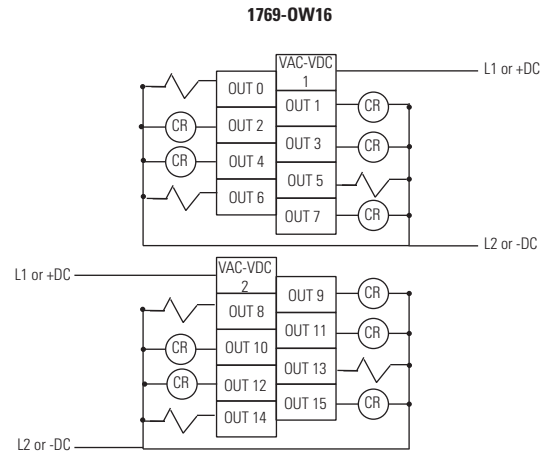
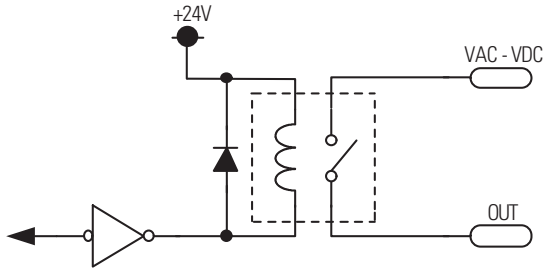

Technical Specifications - 1769-OW16

Attribute	1769-OW16
Outputs	16 normally open (8 points/group)
Operating voltage range	5...265V AC 5...125V DC
Delay, on	10 ms
Delay, off	10 ms
Current draw @ 5.1V	205 mA
Current draw @ 24V	180 mA
Heat dissipation, max	4.75 W
Off-state leakage, max	0 mA
On-state current, min	10 mA @ 5V DC
Current per point, max	2.5 A
Current per module, max	20 A
Isolation voltage	Verified by one of the following dielectric tests: 1836V AC for 1 s or 2596V DC for 1 s, output point to bus 265V AC working voltage (IEC Class 2 reinforced insulation) Verified by one of the following dielectric tests: 1836V AC for 1 s or 2596V DC for 1 s, group to group 265V AC working voltage (basic insulation) 150V AC working voltage (IEC Class 2 reinforced insulation)
Weight, approx.	450 g (0.99 lb)
Dimensions (HxWxD), approx.	118 x 52.5 x 87 mm (4.65 x 2.07 x 3.43 in.) Height with mounting tabs 138 mm (5.43 in.)
Slot width	1.5
Module location	DIN rail or panel mount
Power supply	1769-PA2, 1769-PB2, 1769-PA4, 1769-PB4
Power supply distance rating	8 modules

Technical Specifications - 1769-OW16

Attribute	1769-OW16
Terminal screw torque	0.68 N•m (6 lb•in)
Retaining screw torque	0.46 N•m (4.1 lb•in)
Wire size	(22...14 AWG) solid (22...16 AWG) stranded
Wire type	Cu-90 °C (194 °F)
Replacement terminal block	1769-RTBN18 (1 per kit)
Replacement door label	1769-RL1 (2 per kit)
Replacement door	1769-RD (2 per kit)
Vendor ID code	1
Product type code	7
Product code	85
Enclosure type rating	None (open style)

Relay Contact Ratings - 1769-OW16

Volts, max	Continuous Amps per Point, max	Amperes ⁽¹⁾		Voltamperes		NEMA ICS 2-125
		Make	Break	Make	Break	
240V AC	2.5 A	7.5 A	0.75 A	1800VA	180VA	C300
120V AC		15 A	1.5 A			
125V DC	1.0 A	0.22 A ⁽²⁾		28VA		R150
24V DC	2.0 A	1.2 A ⁽²⁾		28VA		—

⁽¹⁾ Connecting surge suppressors across your external inductive load will extend the life of the relay contacts.

⁽²⁾ For DC voltage applications, the make/break ampere rating for relay contacts can be determined by dividing 28VA by the applied DC voltage. For example, 28VA/48V DC = 0.58 A. For DC voltage applications less than 48V, the make/break ratings for relay contacts cannot exceed 2 A.

Certifications - 1769-OW16

Certification ⁽¹⁾	1769-OW16
c-UL	C-UL certified (under CSA C22.2 No. 142) UL 508 listed Class I, Division 2 Group A,B,C,D Hazardous Locations (UL 1604, C-UL under CSA C22.2 No. 213)
CE	CE compliant for all applicable directives
C-Tick	C-Tick compliant for all applicable directives

⁽¹⁾ When marked. See the Product Certification link at <http://www.ab.com> for Declarations of Conformity, Certificates, and other certification details.

1769-ARM

Compact address reserve module

Use the 1769-ARM address reserve module in CompactLogix systems to cost-effectively reserve module slots. After creating the CompactLogix system's I/O configuration and user program, any I/O module in the system can be removed and replaced with a 1769-ARM module once the removed module is inhibited by using RSLogix 5000 programming software. Inhibiting a module creates an I/O configuration and user program removing all references to that module.

To use the 1769-ARM module in MicroLogix systems, configure a generic module by using RSLogix 5000 programming software. Any user-program references to the slot position occupied by the 1769-ARM module must not use another module's parameters.

Technical Specifications - 1769-ARM

Attribute	1769-ARM
Current draw @ 5.1V	60 mA
Current draw @ 24V	0 mA
Heat dissipation, max	0.3 W
Weight, approx.	280 g (0.62 lb)
Dimensions (HxWxD), approx.	118 x 35 x 87 mm (4.65 x 1.38 x 3.43 in.) Height with mounting tabs 138 mm (5.43 in.)
Slot width	1
Module location	DIN rail or panel mount
Power supply	1769-PA2, 1769-PB2, 1769-PA4, 1769-PB4
Power supply distance rating	8 modules
Vendor ID code	1
Product type code	7
Product code	74
Enclosure type rating	None (open style)

Certifications - 1769-ARM

Certification ⁽¹⁾	1769-ARM
c-UL	C-UL certified (under CSA C22.2 No. 142) UL 508 listed Class I, Division 2 Group A,B,C,D Hazardous Locations (UL 1604, C-UL under CSA C22.2 No. 213)
CE	CE compliant for all applicable directives
C-Tick	C-Tick compliant for all applicable directives

⁽¹⁾ When marked. See the Product Certification link at <http://www.ab.com> for Declarations of Conformity, Certificates, and other certification details.

1769-ASCII

Compact ASCII module

RS-232 Wiring Module to DTE Device (hardware handshaking disabled)

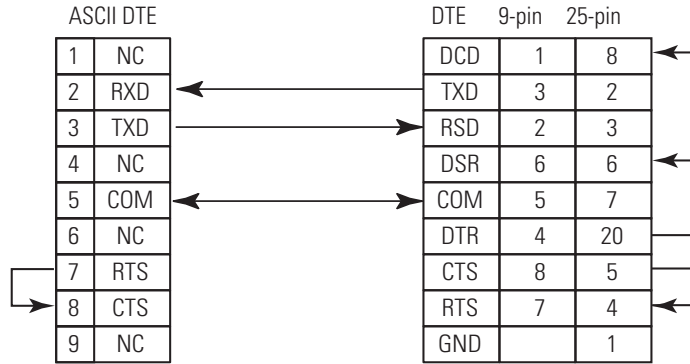

RS-422 Wiring

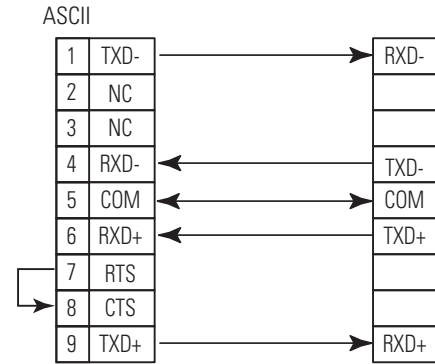

RS-232 Wiring - Module to Printer (hardware handshaking enabled, standard printer adapter cable)

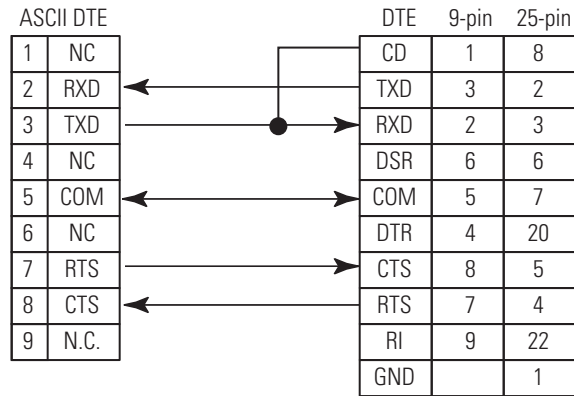

RS-485 Wiring

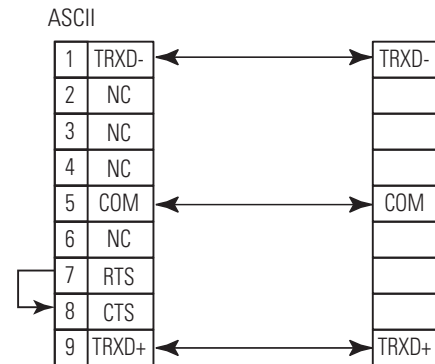

Technical Specifications - 1769-ASCII

Attribute	1769-ASCII
Inputs	2 full duplex (RS-232, RS-422) 2 half duplex (RS-485)
Serial input voltage signal	3...25V DC with respect to signal ground (SG) 0, Asserted, ON, Space, Active -3...-25V DC with respect to signal ground (SG) 1, Disasserted, OFF, Mark, Inactive
Current draw @ 5.1V	425 mA
Current draw @ 24V	0 mA
Power dissipation, max	2.13 W
Thermal dissipation, max	7.3 BTU/hr
Isolation voltage	30V Tested to withstand 710V DC for 60 s
Transmit transaction ID	0...255
Handshaking	RTS/CTS hardware handshaking always enabled
Weight, approx.	0.18 kg (0.40 lb)

Technical Specifications - 1769-ASCII

Attribute	1769-ASCII
Dimensions (HxWxD), approx.	118 x 35 x 87 mm (4.65 x 1.38 x 3.43 in.) Height with mounting tabs 138 mm (5.43 in.)
Slot width	1
Module location	DIN rail or panel mount
Power supply	1769-PA2, 1769-PB2, 1769-PA4, 1769-PB4
Power supply distance rating	4 modules
Recommended cable	Belden 876, shielded
Serial port connectors	Two DB-9 male with pins
Wire category	2 - on communication ports ⁽¹⁾
Vendor ID code	1
Product type code	109
Product code	66
Input words	108
Output words	108
Configuration words	31
Enclosure type rating	None (open style)

⁽¹⁾ Use this conductor category information for planning conductor routing as described in the system level installation manual. See the Industrial Automation Wiring and Grounding Guidelines, publication [1770-4.1](#).

Certifications - 1769-ASCII

Certification ⁽¹⁾	1769-ASCII
c-UL-us	UL Listed for Class I, Division 2 Group A,B,C,D Hazardous Locations, certified for U.S. and Canada.
CE	European Union 89/335/EEC EMC Directive, compliant with: <ul style="list-style-type: none"> • EN 50082-2; Industrial Immunity • EN 61326; Meas./Control/Lab., Industrial Requirements • EN 61000-6-2; Industrial Immunity • EN 61000-6-4; Industrial Emissions
C-Tick	Australian Radiocommunications Act, compliant with: AS/NZS CISPR 11; Industrial Emissions

⁽¹⁾ When marked. See the Product Certification link at <http://www.ab.com> for Declarations of Conformity, Certificates, and other certification details.

1769-BOOLEAN

Compact combination 24V DC sink input/source output BOOLEAN control module

Simplified Input Schematic

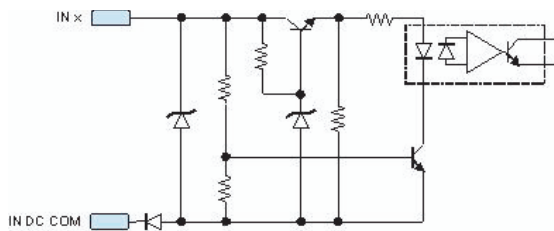

Simplified Output Schematic

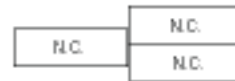
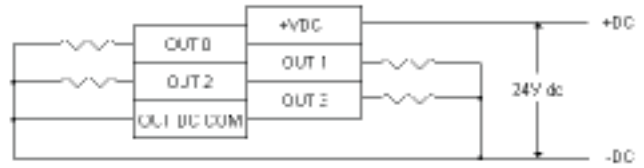
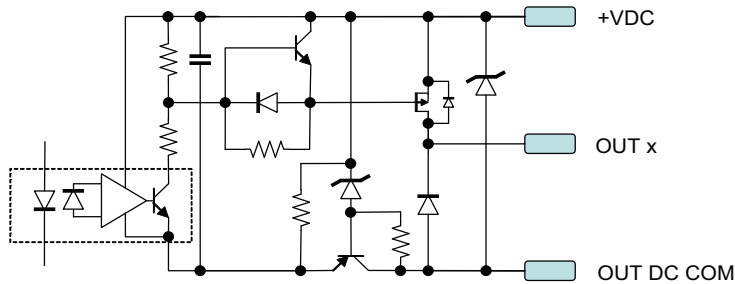

Do not use the NC terminals as connection points.

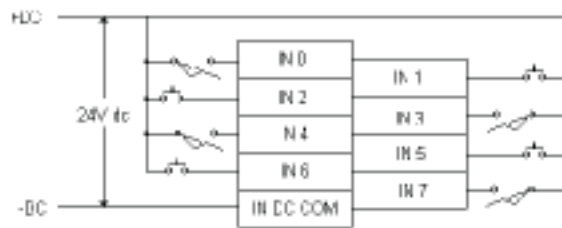

Technical Specifications - 1769-BOOLEAN

Attribute	1769-BOOLEAN
Current draw @ 5.1V	220 mA
Current draw @ 24V	0 mA
Heat dissipation, max	3.55 W
Closed loop time	Output on-state current ≥ 5 mA: 100 μ s max Output on-state current < 5 mA: 150 μ s max
Isolation voltage	Verified by one of the following dielectric tests: 1200V AC for 1 s or 1697V DC for 1 s 75V DC working voltage (IEC Class 2 reinforced insulation)
Weight, approx.	282 g (0.625 lb)
Dimensions (HxWxD), approx.	118 x 35 x 87 mm (4.65 x 1.38 x 3.43 in.) Height with mounting tabs 138 mm (5.43 in.)
Slot width	1
Module location	DIN rail or panel mount
Power supply	1769-PA2, 1769-PB2, 1769-PA4, 1769-PB4

Technical Specifications - 1769-BOOLEAN

Attribute	1769-BOOLEAN
Power supply distance rating	8 modules
Terminal screw torque	0.68 N•m (6 lb•in)
Retaining screw torque	0.46 N•m (4.1 lb•in)
Wire size	(22...14 AWG) solid (22...16 AWG) stranded
Wire type	Cu-90 °C (194 °F)
Vendor ID code	1
Product type code	109
Product code	37
Enclosure type rating	None (open-style)

1769-BOOLEAN Input Specifications

Attribute	1769-BOOLEAN
Inputs	8 real 8 virtual
Voltage category	24V AC sinking
Operating voltage range	10...30V DC @ 30 °C (86 °F) 10...26V DC @ 60 °C (140 °F)
Digital filter, off to on	0 s, 100 µs, 200 µs, 500 µs, 1 ms, 2 ms, 4 ms, 8 ms
Digital filter, on to off	0 s, 100 µs, 200 µs, 500 µs, 1 ms, 2 ms, 4 ms, 8 ms
Input delay, off to on	10 µs
Input delay, on to off	10 µs
Current draw @ 5.1V	115 mA
Off-state voltage, max	5V DC
Off-state current, max	1.5 mA
On-state voltage, min	10V DC
On-state current, min	2 mA
Inrush current, max ⁽¹⁾	250 mA
Input impedance, max	2.0 kΩ @ 24V DC 2.3 kΩ @ 30V DC
IEC input compatibility	Type 1+
Isolation voltage	Verified by one of the following dielectric tests: 1200V AC for 1 s or 1697V DC for 1 s, input point to bus 75V DC working voltage (IEC Class 2 reinforced insulation)

⁽¹⁾ A current limiting resistor can be used to limit inrush current; however, the operating characteristics of the AC input circuit will be affected. If a 6.8 kΩ (2.5 W minimum) resistor is placed in series with the input, the inrush current is reduced to 35 mA. In this configuration the minimum on-state voltage increases to 92V AC. Before adding the resistor in a hazardous environment, be sure to consider the operating temperature of the resistor and the temperature limits of the environment. The operating temperature of the resistor must remain below the temperature limit of the environment.

1769-BOOLEAN Output Specifications

Attribute	1769-BOOLEAN
Outputs	4
Voltage category	24V DC, sourcing
Operating voltage range	20.4...26.4V DC
Output delay, on ⁽¹⁾	10 μ s, output on-state current \geq 5 mA
Output delay, off ⁽¹⁾	10 μ s, output on-state current \geq 5 mA
Off-state leakage current, max ⁽²⁾	1.0 mA @ 26.4V DC
On-state current, max	1.0 mA
On-state voltage drop, max	1.0V DC @ 1 A
Current per point, max	0.5 A @ 60 °C (140 °F) 1.0 A @ 30 °C (86 °F)
Surge current ⁽³⁾	2 A for 10 ms, repeatable every 2 s
Isolation voltage	Verified by one of the following dielectric tests: 1200V AC for 1 s or 1697V DC for 1 s, output point to bus 75V DC working voltage (IEC Class 2 reinforced insulation)

⁽¹⁾ Triac outputs turn on and off at AC line zero cross.

⁽²⁾ To limit the effects of leakage current through solid state outputs, a loading resistor can be connected in parallel with your load. For 120V AC operation, use a 15 k Ω , 2 W resistor. For 240V AC operation use a 5 k Ω , 5 W resistor.

⁽³⁾ Connecting surge suppressors across your external load will extend the life of the triac outputs.

Temperature Derating - 1769-BOOLEAN

1769-BOOLEAN Maximum Amperes per Point versus Temperature

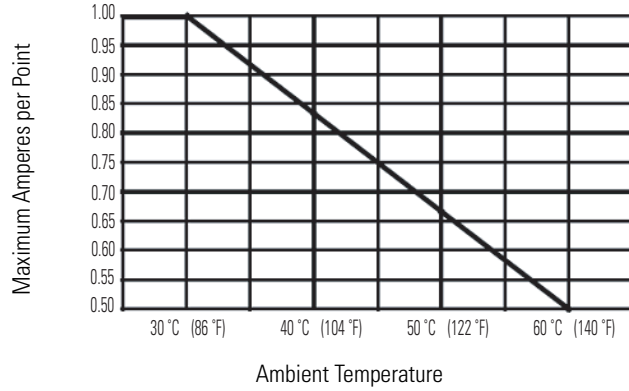

1769-BOOLEAN Maximum Amperes per Module versus Temperature

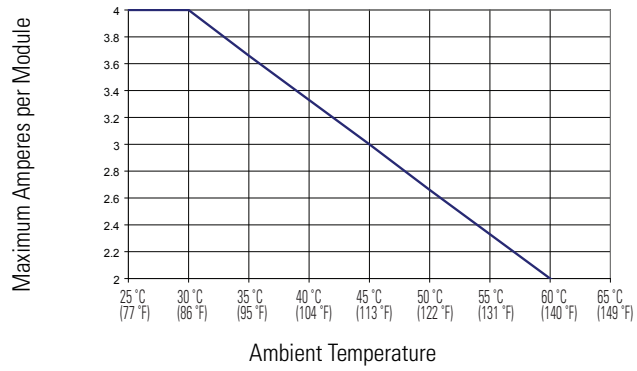

Transistor Output Transient Pulses - 1769-BOOLEAN

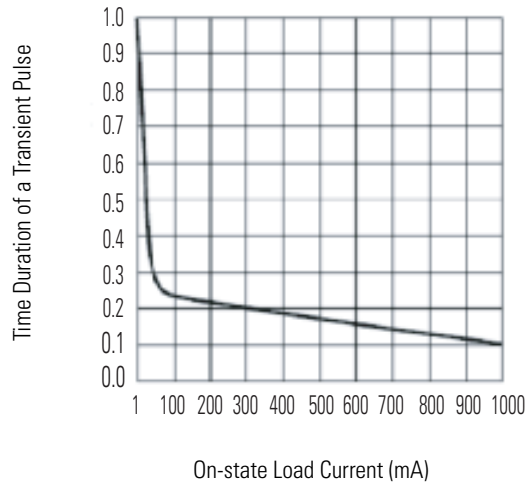

Certifications - 1769-BOOLEAN

Certification⁽¹⁾	1769-BOOLEAN
c-UL	C-UL certified (under CSA C22.2 No. 142) UL 508 listed Class I, Division 2 Group A,B,C,D Hazardous Locations (UL 1604, C-UL under CSA C22.2 No. 213)
CE	CE compliant for all applicable directives

⁽¹⁾ When marked. See the Product Certification link at <http://www.ab.com> for Declarations of Conformity, Certificates, and other certification details.

1769-HSC

Compact high-speed counter module

Differential Encoder Wiring

See the encoder manual for proper cable type. The type of cable used should be twisted pair, individually shielded cable with a maximum length of 300 m (1000 ft).

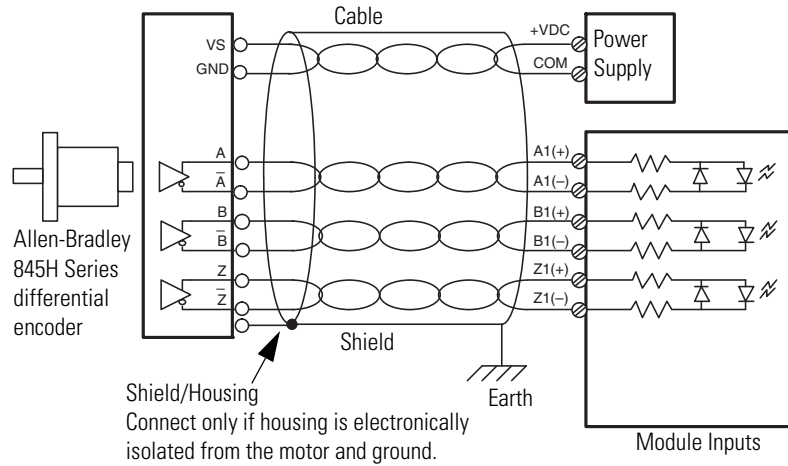

Single-Ended Encoder Wiring

See the encoder manual for proper cable type. The type of cable used should be twisted pair, individually shielded cable with a maximum length of 300 m (1000 ft).

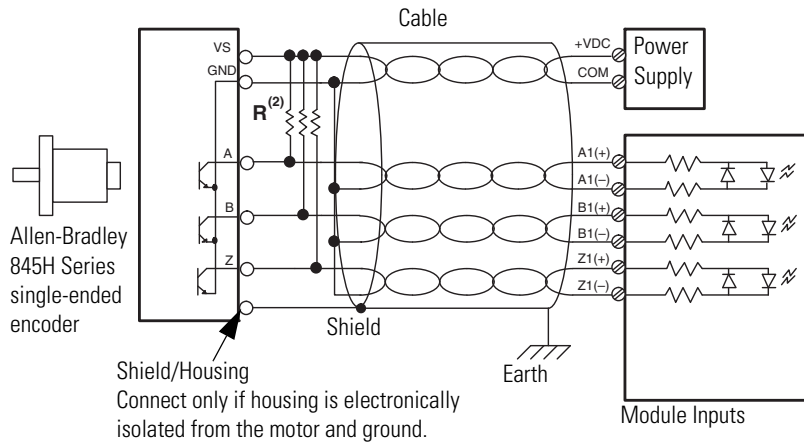

External resistors are required if they are not internal to the encoder. The pull-up resistor (R) value depends on the power supply value. To calculate the maximum resistor value, the following formula:

$$R = \frac{(V_{dc} - V_{min})}{I_{min}}$$

where:

- R = maximum pull-up resistor value
- VDC = power supply voltage
- Vmin = 2.6V DC
- min = 6.8 mA

Power Supply Voltage (V DC)	Pull-up Resistor Value Max (R) ⁽¹⁾
5V DC	352 Ω
12V DC	1382 Ω
24V DC	3147 Ω

⁽¹⁾ Resistance values may change, depending upon your application.

The minimum resistor (R) value depends on the current sinking capability of the encoder.

Discrete Device Wiring

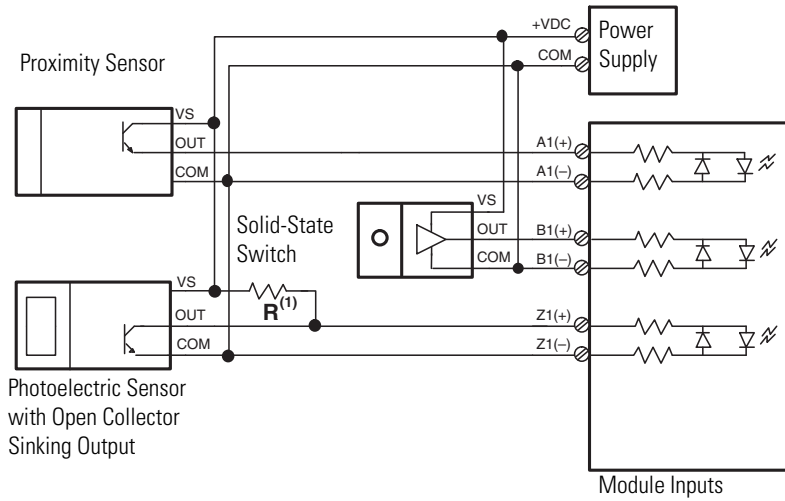

External resistors are required if they are not internal to the encoder. The pull-up resistor (R) value depends on the power supply value. To calculate the maximum resistor value, the following formula:

$$R = \frac{V_{dc} - V_{min}}{I_{min}}$$

where:

- R = maximum pull-up resistor value
- VDC = power supply voltage
- Vmin = 2.6V DC
- min = 6.8 mA

Power Supply Voltage (V DC)	Pull-up Resistor Value Max (R) ⁽¹⁾
5V DC	352 Ω
12V DC	1382 Ω
24V DC	3147 Ω

⁽¹⁾ Resistance values may change, depending upon your application.

The minimum resistor (R) value depends on the current sinking capability of the encoder.

Output Wiring

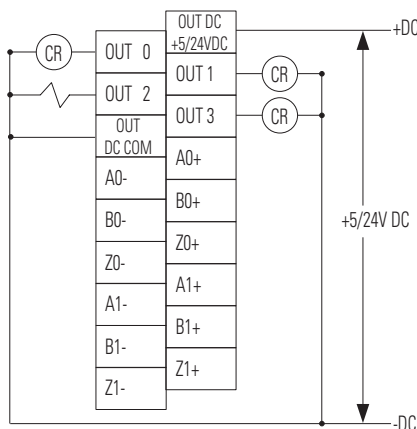

Technical Specifications - 1769-HSC

Attribute	1769-HSC
Current draw @ 5.1V	425 mA
Current draw @ 24V	0 mA
Heat dissipation, max	6.21 W
Weight, approx.	309 g (0.681 lb)
Dimensions (HxWxD), approx.	118 x 35 x 87 mm (4.65 x 1.38 x 3.43 in.) Height with mounting tabs 138 mm (5.43 in.)
Slot width	1
Module location	DIN rail or panel mount
Power supply	1769-PA2, 1769-PB2, 1769-PA4, 1769-PB4
Power supply distance rating	4 modules
Terminal screw torque	0.68 N•m (6 lb•in)
Retaining screw torque	0.46 N•m (4.1 lb•in)
Wire size	(22...14 AWG) solid (22...16 AWG) stranded
Wire type	Cu-90 °C (194 °F)
Vendor ID code	1
Product type code	109
Product code	19
Enclosure type rating	None (open-style)

1769-HSC Input Specifications

Attribute	1769-HSC
Inputs	2
Input voltage range	-30...30V DC
On-state voltage, max	30V DC
On-state voltage, min	2.6V DC
On-state current, min	6.8 mA
Off-state voltage, max	1.0V DC
Off-state current, max	1.5 mA
Off-state leakage current, max	1.5 mA
Input current, max	15 mA
Input current, min	6.8 mA
Input impedance	1950 Ω
Pulse width, min	250 ns
Phase separation, min	131 ns
Input frequency, max	1 MHz
Isolation voltage	Verified by one of the following dielectric tests: 1200V AC or 1697V DC for 1 s, input to bus and input to input 75V DC working voltage (IEC Class 2 reinforced insulation)

1769-HSC Output Specifications

Attribute	1769-HSC
Outputs	4
Output voltage range	5...30V DC
On-state voltage, max	User power - 0.1V DC
On-state output current per point, max	1 A
On-state output current per module, max	4 A
On-state output current, min	1 mA
On-state voltage drop, max	0.5V DC
Off-state leakage current, max	5 μ A
Turn on time, max	400 μ s ⁽¹⁾
Turn off time, max	200 μ s
Reverse polarity protection	30V DC
Isolation voltage	Verified by one of the following dielectric tests: 1200V AC or 1697V DC for 1 s, output to bus 75V DC working voltage (IEC Class 2 reinforced insulation)

⁽¹⁾ Maximum turn-on time applies to output voltage range of 5...7V DC. For output voltages greater than 7V DC, the maximum turn-on time is 200 μ s.

Temperature Derating - 1769-HSC

Maximum Input Voltage - 24V DC Operation

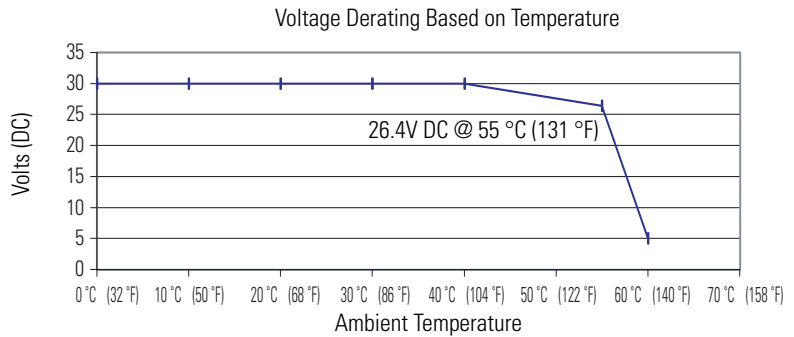

Temperature	Derated Voltage ⁽¹⁾
0...40 °C (32...104 °F)	30V DC
55 °C (131 °F)	26.4V DC
60 °C (140 °F)	5V DC

⁽¹⁾ Input voltage derating between 55°C and 60°C is achieved by using a dropping resistor.
For 24V DC input voltage, use a 2.4 k Ω , ½ Watt resistor.
For input voltages other than 24V DC, use a ½ Watt resistor with value: 125 x (V_{in} - 5V).

Maximum Output Voltage - 24V DC Operation

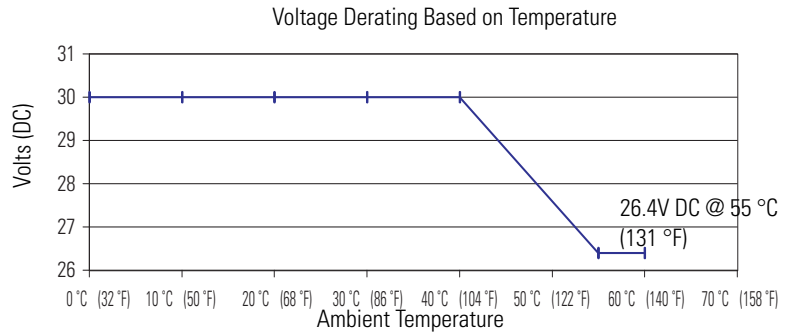

Temperature	Derated Voltage
0...40 °C (32...104 °F)	30V DC
55...60 °C (131...140 °F)	26.4V DC

Maximum Output Current per Point - 5V DC Operation

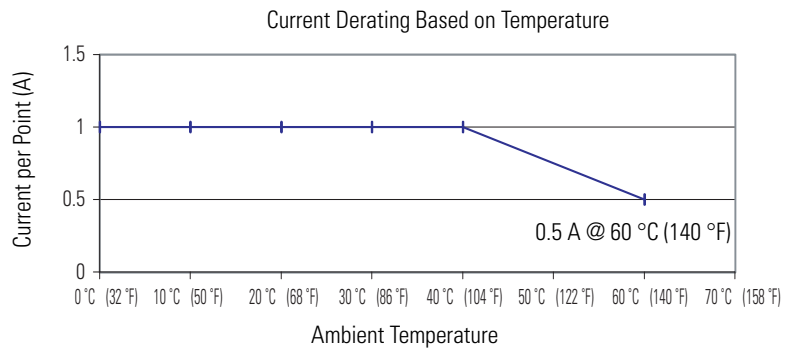

Temperature	Derated Current
0...40 °C (32...104 °F)	1 A
60 °C (140 °F)	0.5 A

Maximum Output Current per Module - 5V DC Operation

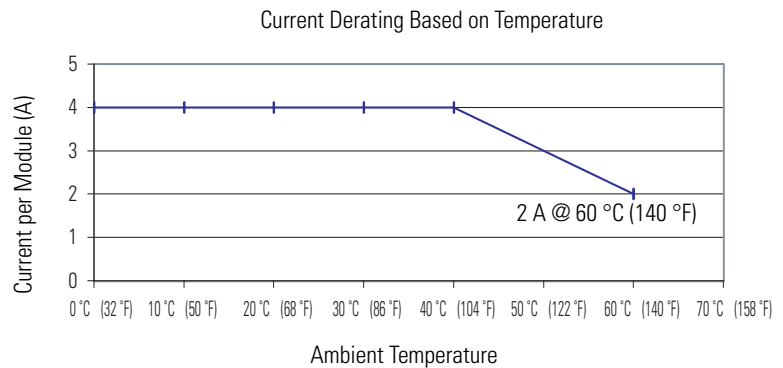

Temperature	Derated Current
0...40 °C (32...104 °F)	4 A
60 °C (140 °F)	2 A

Maximum Output Current per Point - 24V DC Operation

Current Derating Based on Temperature

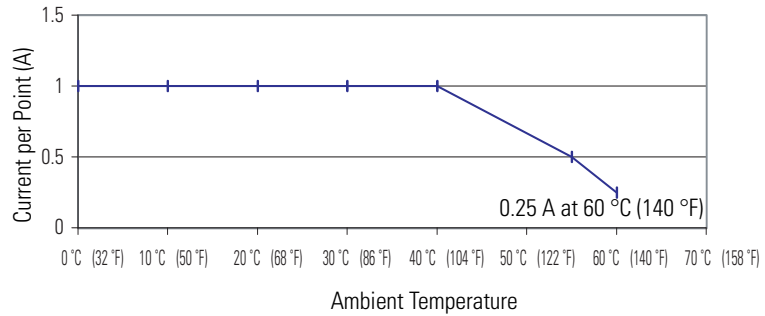

Temperature	Derated Current
0...40 °C (32...104 °F)	1 A
55 °C (131 °F)	0.5 A
60 °C (140 °F)	0.25 A

Maximum Output Current per Module - 24V DC Operation

Current Derating Based on Temperature

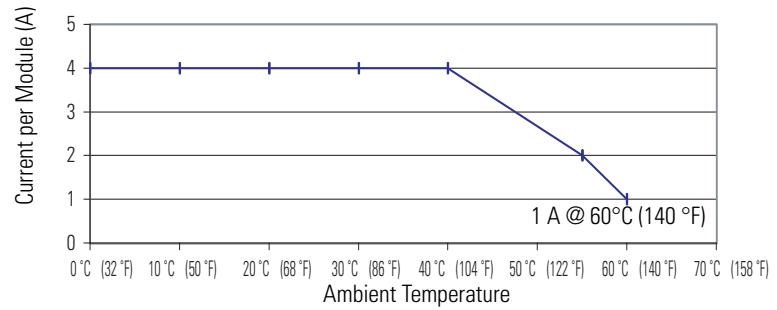

Temperature	Derated Current
0...40 °C (32...104 °F)	4 A
55 °C (131 °F)	2 A
60 °C (140 °F)	1 A

Certifications - 1769-HSC

Certification ⁽¹⁾	1769-HSC
c-UL	C-UL certified (under CSA C22.2 No. 142) UL 508 listed
CE	CE compliant for all applicable directives

⁽¹⁾ When marked. See the Product Certification link at <http://www.ab.com> for Declarations of Conformity, Certificates, and other certification details.

Compact I/O Accessories

Category	Cat. No.	Description
End cap	1769-ECL	Left-end cap for Compact I/O system
	1769-ECR	Right-end cap for Compact I/O system
Expansion cable	1769-CLL1	Left bank-to-left bank expansion 305 mm (1 ft)
	1769-CLL3	Left bank-to-left bank expansion 1 m (3.28 ft)
	1769-CRR1	Right bank-to-right bank expansion 305 mm (1 ft)
	1769-CRR3	Right bank-to-right bank expansion 1 m (3.28 ft)
	1769-CRL1	Right bank-to-left bank expansion 305 mm (1 ft)
	1769-CRL3	Right bank-to-left bank expansion 1 m (3.28 ft)
Replacement terminal block	1769-RTBN10	10-pin NEMA terminal block
	1769-RTBN18	18-pin NEMA terminal block
Replacement door labels	1769-RL1	Replacement door labels for digital I/O, 2 per kit
	1769-RL2	Replacement door labels for analog and specialty I/O, 2 per kit
Replacement doors	1769-RD	Door replacement kit, 2 per kit
Replacement connector kit	1746-N3	Connector kit to terminate a cable which connects field I/O devices to 32-point I/O modules, 1 connector and 40 terminals

End Caps

The final I/O bank in Compact system needs an end cap on the end without the expansion cable. The 1769-L23x controller comes with a right-end cap, so you do not need to order one separately.

Technical Specifications - 1769-ECL, 1769-ECR

Attribute	1769-ECL	1769-ECR
Current draw @ 5.1V	5 mA	
Current draw @ 24V	0 mA	
Weight, approx.	130 g (0.286 lb)	
Location	Left end	Right end
North American temperature code	T3C	
IEC temperature code	N/A	T4
Enclosure type rating	None (open-style)	None (open-style)

Mounting Dimensions - 1769-ECL

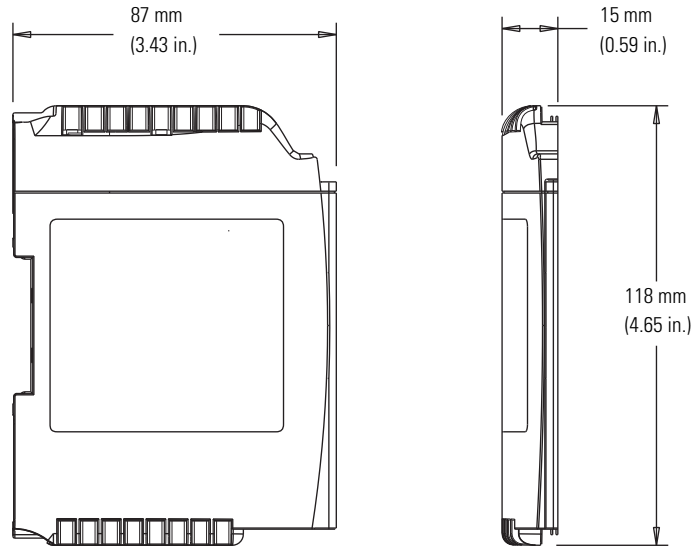

Mounting Dimensions - 1769-ECR

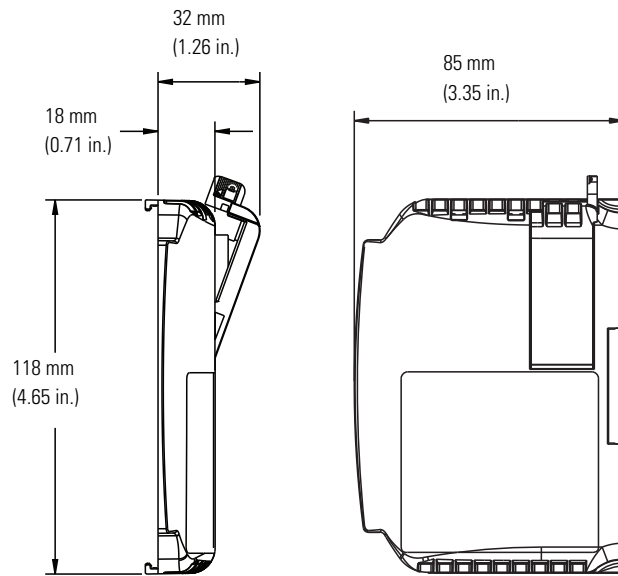

Certifications - 1769-ECL, 1769-ECR

Certification ⁽¹⁾	1769-ECL	1769-ECR
c-UL	UL Listed for Class I, Division 2 Group A, B, C, D Hazardous Locations, certified for U.S. and Canada. See UL File E10314	
CE	European Union 2004/108/EC EMC Directive, compliant with: <ul style="list-style-type: none"> • EN 61000-6-2; Industrial Immunity • EN 61000-6-4; Industrial Emissions 	
C-Tick	Australian Radiocommunications Act, compliant with: <ul style="list-style-type: none"> • AS/NZS CISPR 11; Industrial Emissions 	
ATEX	N/A	European Union 94/9/EC ATEX Directive, compliant with: <ul style="list-style-type: none"> • EN 60079-15; Potentially Explosive Atmospheres, Protection "n" (II 3 G Ex nA IIC T4 X) • EN 60079-0; General Requirements (Zone 2)

⁽¹⁾ When marked. See the Product Certification link at <http://www.ab.com> for Declarations of Conformity, Certificates, and other certification details.

Expansion Cables

The 1769-CLL_x, -CRR_x, and -CRL_x cables extend the 1769 bus communication lines. A maximum of two cables can be used in a 1769 system, allowing for three groups or banks of I/O modules. Each bank requires its own power supply.

Technical Specifications - 1769-CLL_x, 1769-CRR_x, 1769-CRL_x

Attribute	1769-CLL1, 1769-CRR1, 1769-CRL1	1769-CLL3, 1769-CRR3, 1769-CRL3
Weight, approx.	300 g (0.66 lb)	350 g (0.77 lb)
Length	305 mm (1 ft)	1 m (3.28 ft)

Dimensions - 1769-CLLx, 1769-CRRx, 1769-CRLx

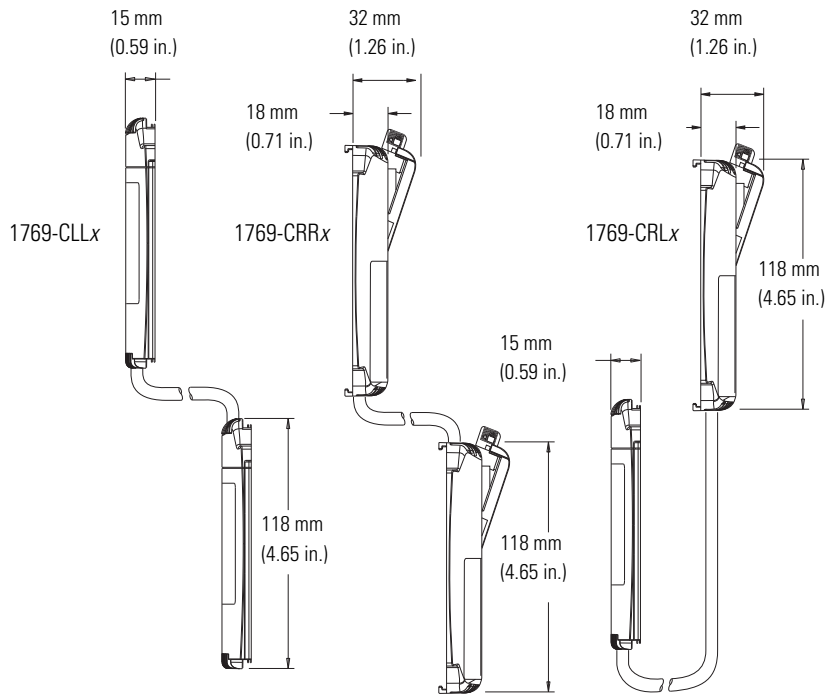

Certifications - 1769-CLLx, 1769-CRRx, 1769-CRLx

Certification ⁽¹⁾	1769-CLLx, 1769-CRRx, 1769-CRLx
c-UL	C-UL certified (under CSA C22.2 No. 142) UL 508 listed Class I, Division 2 Group A,B,C,D Hazardous Locations (UL 1604, C-UL under CSA C22.2 No. 213)
CE	CE compliant for all applicable directives

⁽¹⁾ When marked. See the Product Certification link at <http://www.ab.com> for Declarations of Conformity, Certificates, and other certification details.

Compact I/O Mounting Dimensions

Single 1769 Slot Dimensions

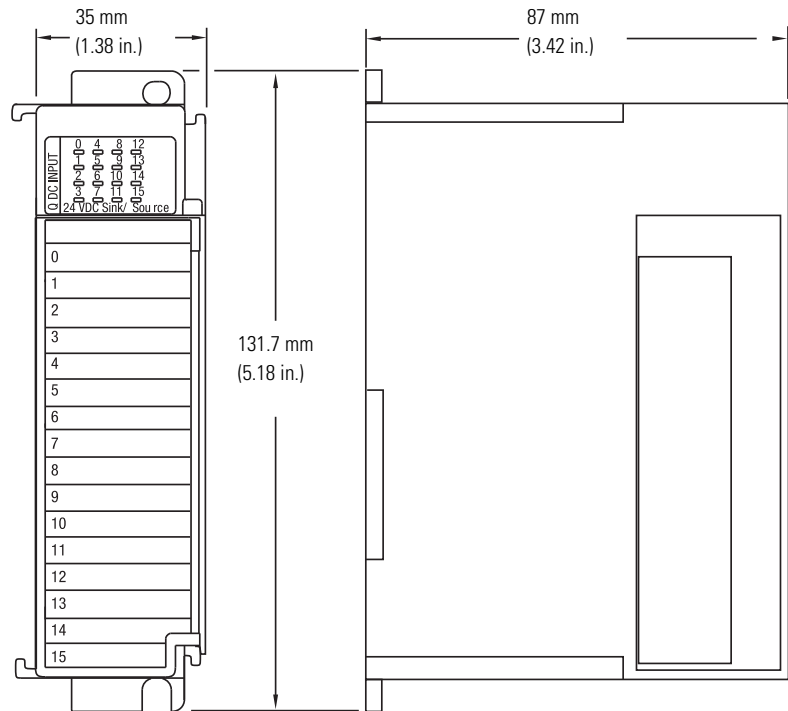

One-and-a-half 1769 Slot Dimensions

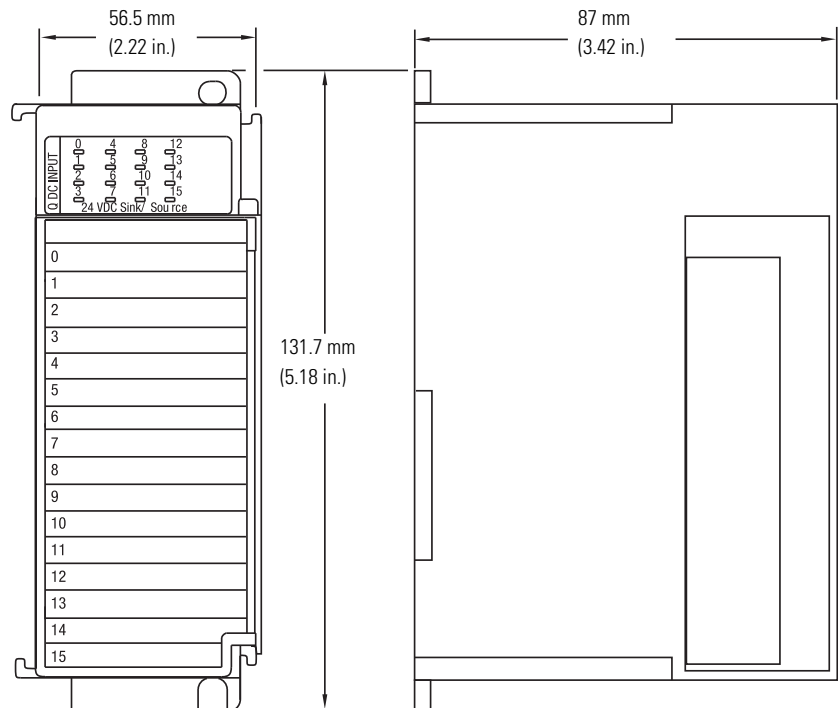

Wiring Systems



As an alternative to buying removable terminal blocks (RTBs) and connecting the wires yourself, you can buy a wiring system of:

- interface modules (IFMs) that provide the output terminal blocks for digital I/O modules. Use the pre-wired cables that match the I/O module to the IFM.
- analog interface modules (AIFMs) that provide the output terminal blocks for analog I/O modules. Use the pre-wired cables that match the I/O module to the AIFM.
- I/O module-ready cables. One end of the cable assembly is an RTB that plugs into the front of the I/O module. The other end has individually color-coded conductors that connect to a standard terminal block.

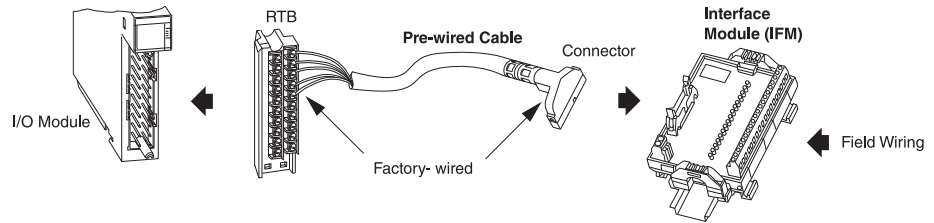

PanelConnect Modules

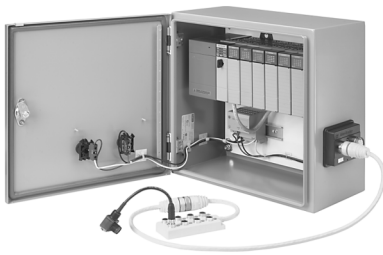

A PanelConnect module and its sensor connection system connect sensors directly to I/O modules by using convenient pre-built cables and connectors.

The PanelConnect module mounts on the enclosure and creates the correct seal for the entry of the sensor connections. You do not need to seal the opening where the sensor cables enter the enclosure, create custom connectors, or wire to those custom connectors.

Notes:

Rockwell Automation Support

Rockwell Automation provides technical information on the Web to assist you in using its products. At <http://www.rockwellautomation.com/support/>, you can find technical manuals, a knowledge base of FAQs, technical and application notes, sample code and links to software service packs, and a MySupport feature that you can customize to make the best use of these tools.

For an additional level of technical phone support for installation, configuration, and troubleshooting, we offer TechConnect support programs. For more information, contact your local distributor or Rockwell Automation representative, or visit <http://www.rockwellautomation.com/support/>.

Installation Assistance

If you experience an anomaly within the first 24 hours of installation, review the information that is contained in this manual. You can contact Customer Support for initial help in getting your product up and running.

United States or Canada	1.440.646.3434
Outside United States or Canada	Use the Worldwide Locator at http://www.rockwellautomation.com/support/americas/phone_en.html , or contact your local Rockwell Automation representative.

New Product Satisfaction Return

Rockwell Automation tests all of its products to ensure that they are fully operational when shipped from the manufacturing facility. However, if your product is not functioning and needs to be returned, follow these procedures.

United States	Contact your distributor. You must provide a Customer Support case number (call the phone number above to obtain one) to your distributor to complete the return process.
Outside United States	Please contact your local Rockwell Automation representative for the return procedure.

Documentation Feedback

Your comments will help us serve your documentation needs better. If you have any suggestions on how to improve this document, complete this form, publication [RA-DU002](#), available at <http://www.rockwellautomation.com/literature/>.

www.rockwellautomation.com

Power, Control and Information Solutions Headquarters

Americas: Rockwell Automation, 1201 South Second Street, Milwaukee, WI 53204 USA, Tel: (1) 414.382.2000, Fax: (1) 414.382.4444

Europe/Middle East/Africa: Rockwell Automation, Vorstlaan/Boulevard du Souverain 36, 1170 Brussels, Belgium, Tel: (32) 2 663 0600, Fax: (32) 2 663 0640

Asia Pacific: Rockwell Automation, Level 14, Core F, Cyberport 3, 100 Cyberport Road, Hong Kong, Tel: (852) 2887 4788, Fax: (852) 2508 1846