

128-bit High-Voltage Digital Input Board with Built-in-Test and Input Filter

- 128 bits of high-voltage digital inputs
- 3 ms input noise suppression filter
- Each group of eight inputs are jumper-selectable to monitor voltage source or current sinking signals
- On-board Built-in-Test logic for fault detection and isolation
- User-selectable input voltage thresholds (0.67 to 31 V)
- VMEbus compatible (ANSI/IEEE STD 1014-1987 IEC 821 and 297)
- A24:A16: D32/D16/D08 (EO): slave: 39/3D:29/2D
- Double Eurocard form factor (6U)
- Front panel with fail LED
- MTBF: 136,969 hrs. (217F)

FUNCTIONAL CHARACTERISTICS

Compliance: This product complies with the VMEbus specification (ANSI/IEEE STD 1014-1987, IEC 821 and 297), with the following mnemonics:

A24:A16: D32/D16/D08 (EO): Slave:39/3D:
29/2D
Form Factor: 6U

Input Connector Type: Two 96-pin female connectors are used with this board. For mass terminations (IDC), an ERNI IDC DIN connector and 0.033-inch 30 AWG ribbon cable are recommended. The ERNI order numbers are:

96-pin connector 913 031
96-conductor 0.033-inch cable 913 049

For discrete wire use, Harting connectors are recommended. This connector consists of a contact housing with female crimp-on contacts. Harting order numbers are:

96-pin connector 09 03 096 3214
Female crimp-on contacts 09 02 000 8484
Crimp tool (for stripped wire) 09 99 000 0075

Either connector needs a shell housing that has holding levers. We recommend the Harting housing. Its order number is 09 03 096 0501. This shell is used with the discrete wire cable. Thus, this housing will latch the discrete wire cable to the board connector and provide a strain relief.

I/O Organization: Sixteen input ports, eight bits wide for a total of 128 inputs, addressable to any address within the short supervisory and/or short nonprivileged or the standard supervisory data and/or standard nonprivileged data I/O map.

Addressing Scheme: Thirty-two individually addressable on 8-, 16-, or 32-bit boundaries. A Board ID Register is located at the base address of the board. A Control and Status Register (CSR) is stacked above the ID Register. The sixteen input

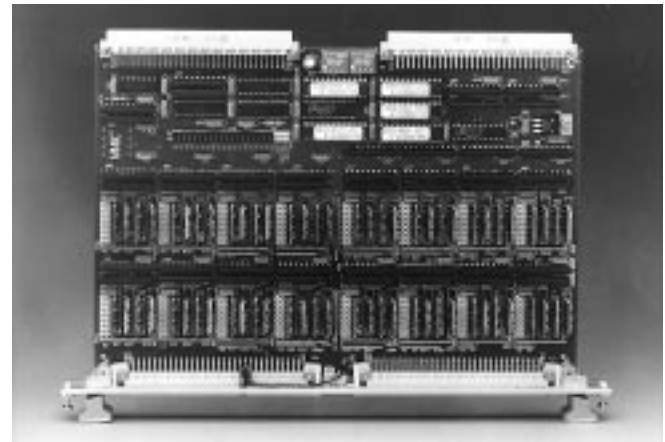

bytes are placed above the CSR. Twenty jumpers establish the base address of the board. Another jumper is used for standard or short I/O accesses. The following address map shows the relative locations of all the registers used by the board:

TRADEMARKS

Registered trademarks are the property of their respective owners.

| ORDERING INFORMATION | | | | | | | | | |
|--|--|----------------------------|---|---|---|---|---|---|--|
| October 20, 1997 | 800-001129-000 E | A | B | C | - | D | E | F | |
| VMIVME-1129 | | - | O | O | - | | | | |
| A = Input Types 0 = Voltage Sourcing/Current Sinking 1 = Contact Sensing for 24 V Only BC = 00 (Options reserved for future use) | | | | | | | | | |
| RECOMMENDED CONNECTOR COMPONENTS FOR CABLING TO P3 AND P4 | | | | | | | | | |
| Style | Description | I/O Connectors | | | | | | | |
| 96-pin IDC | Mating Connector (96-pin Mass Terminated) | ERNI No. 913 031 | | | | | | | |
| | 0.033-inch Ribbon Cable (96-pin Mass Terminated) | ERNI No. 913 049 | | | | | | | |
| 96-pin Discrete Wire | Mating Connector (96-pin Discrete) | Harting No. 09 03 096 3214 | | | | | | | |
| | Female Crimp Contacts (for 96-pin Discrete) | Harting No. 09 02 000 8484 | | | | | | | |
| Both | Connector Shell Housing (for 96-pin Connectors) | Harting No. 09 03 096 0501 | | | | | | | |
| | PC Board Connector Part Number | ERNI No. 913 216 | | | | | | | |
| *The Harting crimp tool part number is 09 99 000 0075. | | | | | | | | | |
| For Ordering Information, Call: 1-800-322-3616 or 1-205-880-0444 • FAX (205) 882-0859 E-mail: info@vmic.com Web Address: www.vmic.com Copyright © July 1992 by VMIC Specifications subject to change without notice. | | | | | | | | | |

Address Map:

| Decoded address bits | | | | Register name or description |
|----------------------|----|----|----|-----------------------------------|
| A4 | A3 | A2 | A1 | |
| 0 | 0 | 0 | 0 | Board ID |
| 0 | 0 | 0 | 1 | Control and Status Register (CSR) |
| 0 | 0 | 1 | 0 | Not Used |
| 0 | 0 | 1 | 1 | Not Used |
| 0 | 1 | 0 | 0 | Not Used |
| 0 | 1 | 0 | 1 | Not Used |
| 0 | 1 | 1 | 0 | Not Used |
| 0 | 1 | 1 | 1 | Not Used |
| 1 | 0 | 0 | 0 | Input Data Word (16 bits) 0 |
| 1 | 0 | 0 | 1 | Input Data Word (16 bits) 1 |
| 1 | 0 | 1 | 0 | Input Data Word (16 bits) 2 |
| 1 | 0 | 1 | 1 | Input Data Word (16 bits) 3 |
| 1 | 1 | 0 | 0 | Input Data Word (16 bits) 4 |
| 1 | 1 | 0 | 1 | Input Data Word (16 bits) 5 |
| 1 | 1 | 1 | 0 | Input Data Word (16 bits) 6 |
| 1 | 1 | 1 | 1 | Input Data Word (16 bits) 7 |

Input Circuit Characteristics: The inputs are single-ended with a high input impedance (33 kΩ) and a threshold accuracy of 10 percent (typical) over the entire 66 V input range. Refer to Figures 3 through 5 for typical single-ended signal conditioning configurations. Table 1 lists the threshold levels for inputs using the stated input range.

Built-in-Test: This board is designed with built-in-test logic that supports a board-level diagnostic which exercises all of the on-board active components. Special output registers are provided to test the input circuitry. These registers are controlled by a test mode bit in the CSR. Thus, the user can monitor the data written to this board and determine if it is functioning properly. A front panel Fail LED is provided to help in isolating a faulty board. This LED

is illuminated at power up and can be extinguished under program control upon the successful completion of user-defined diagnostic software.

Input Noise Filter: The input filter is a single pole filter with a 3 ms time constant. The following table gives constant values for ALL bits of the port.*

| | Minimum | Typical | Maximum |
|------------------------|---------|---------|---------|
| Low to High Transition | 1.6 ms | 2.0 ms | 3.2 ms |
| High to Low Transition | 2.6 ms | 3.8 ms | 4.4 ms |

*Filter has Z5U temperature characteristics.

PHYSICAL/ENVIRONMENTAL

Temperature Range: 0 to 55 °C , operating, -20 to 85 °C, storage

Relative Humidity Range: 20 to 80 percent, noncondensing

Altitude: Operation to 10,000 ft

Cooling: Forced air convection

Dimensions: Double Eurocard (6U), 160 x 233.35 mm

Power Requirements: 1.65 A (typical) at 5 V
This power requirement is determined by the user load. Connections can be made at either the front panel (P3 or P4) or at P2. To facilitate connections made at P2, VMIC offers the VMIACC-0130 P2 Power Accessory which is recommended, but not required.

APPLICATION AND CONFIGURATION GUIDES — The following Application and Configuration Guides are available from VMIC to assist the user in the selection, specification, and implementation of systems based on VMIC's products.

| Title | Document No. |
|--|----------------|
| Digital Input Board Application Guide | 825-000000-000 |
| Change-of-State Board Application Guide | 825-000000-002 |
| Digital I/O (with Built-in-Test) Product Line Description | 825-000000-003 |
| Synchro/Resolver (Built-in-Test) Subsystem Configuration Guide | 825-000000-004 |
| Analog I/O Products (with Built-in-Test) Configuration Guide | 825-000000-005 |
| Connector and I/O Cable Application Guide | 825-000000-006 |
| Data Acquisition Noise Reduction Application Guide | 825-000000-026 |
| Installation Guide for the P2 Power Adapter | 522-800130-000 |

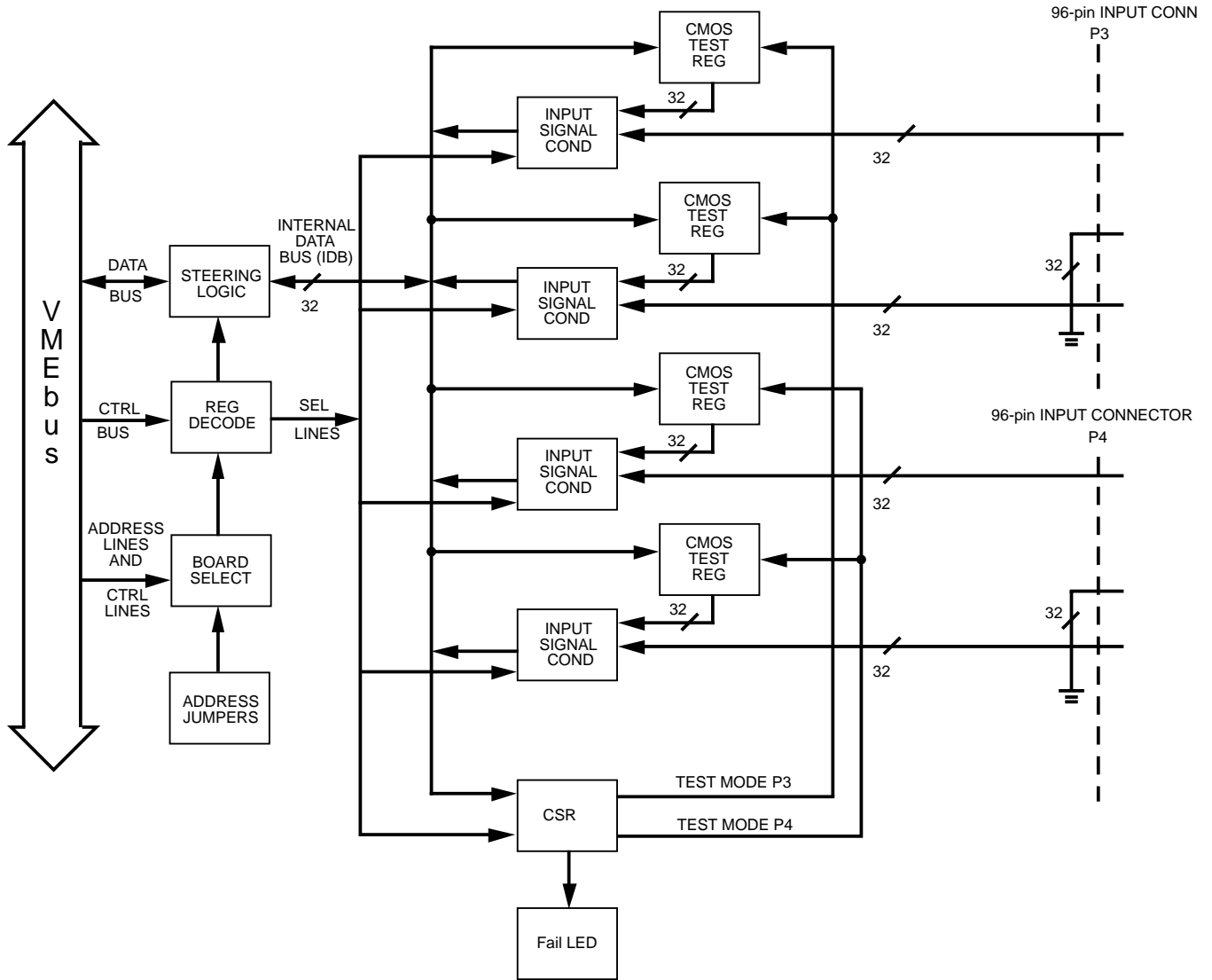
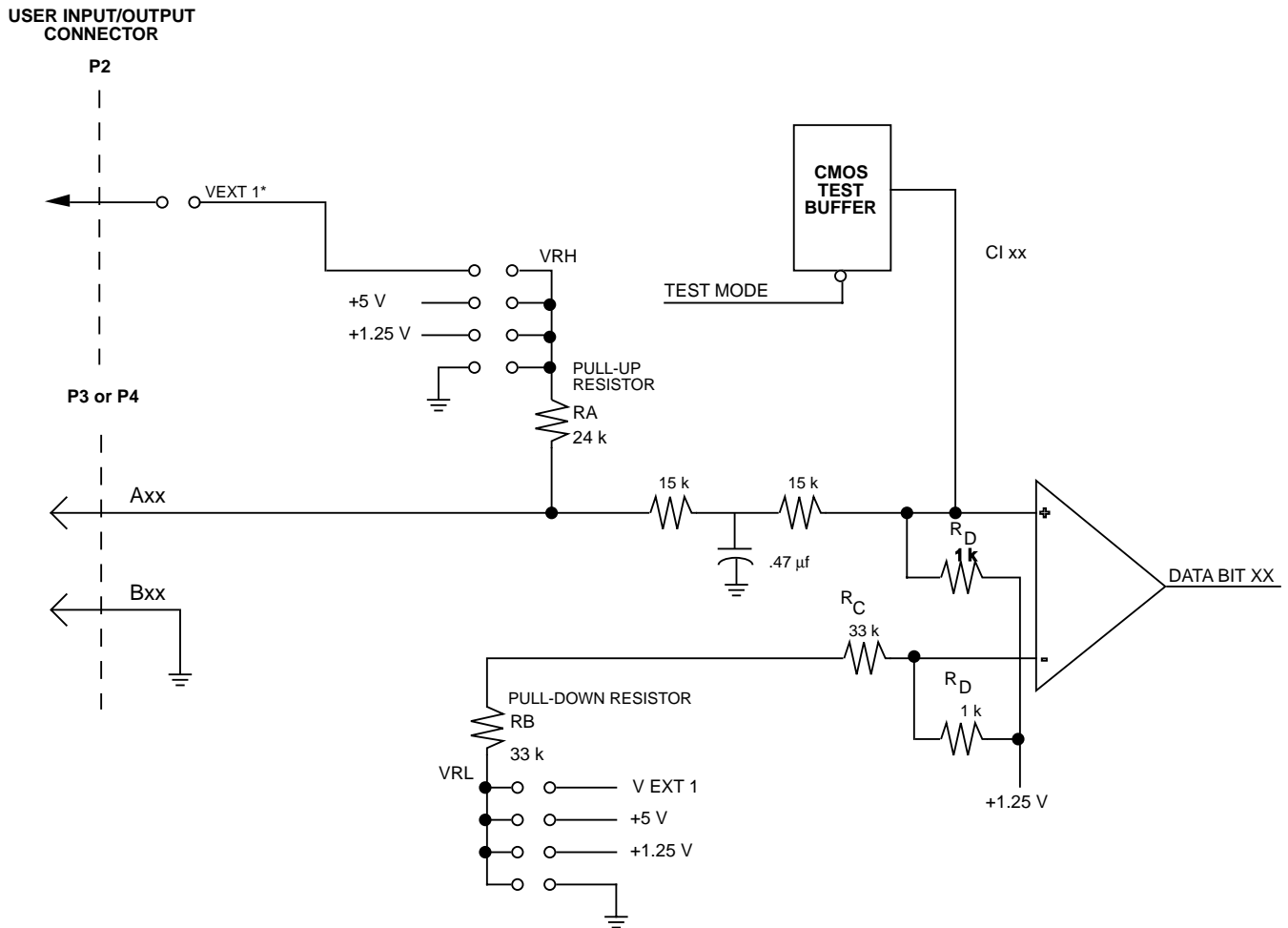

Figure 1. Block Diagram of the VMIVME-1129



*Each group of channels (8 channels per group) has a separate jumper field for external voltage signals.

Figure 2. Typical Input Signal Conditioning

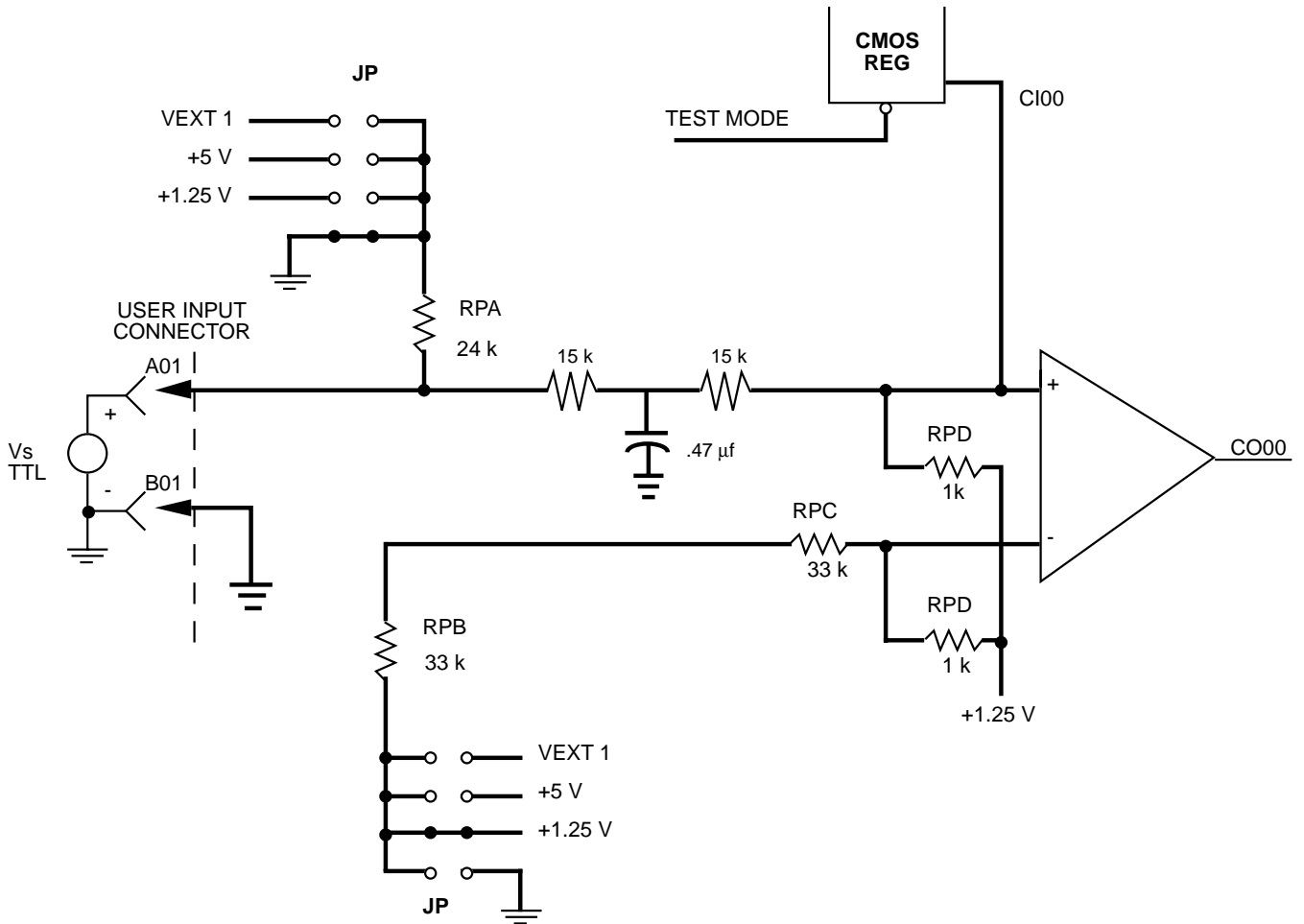

Figure 3. Input Configuration for Voltage Sourcing Inputs at TTL Levels

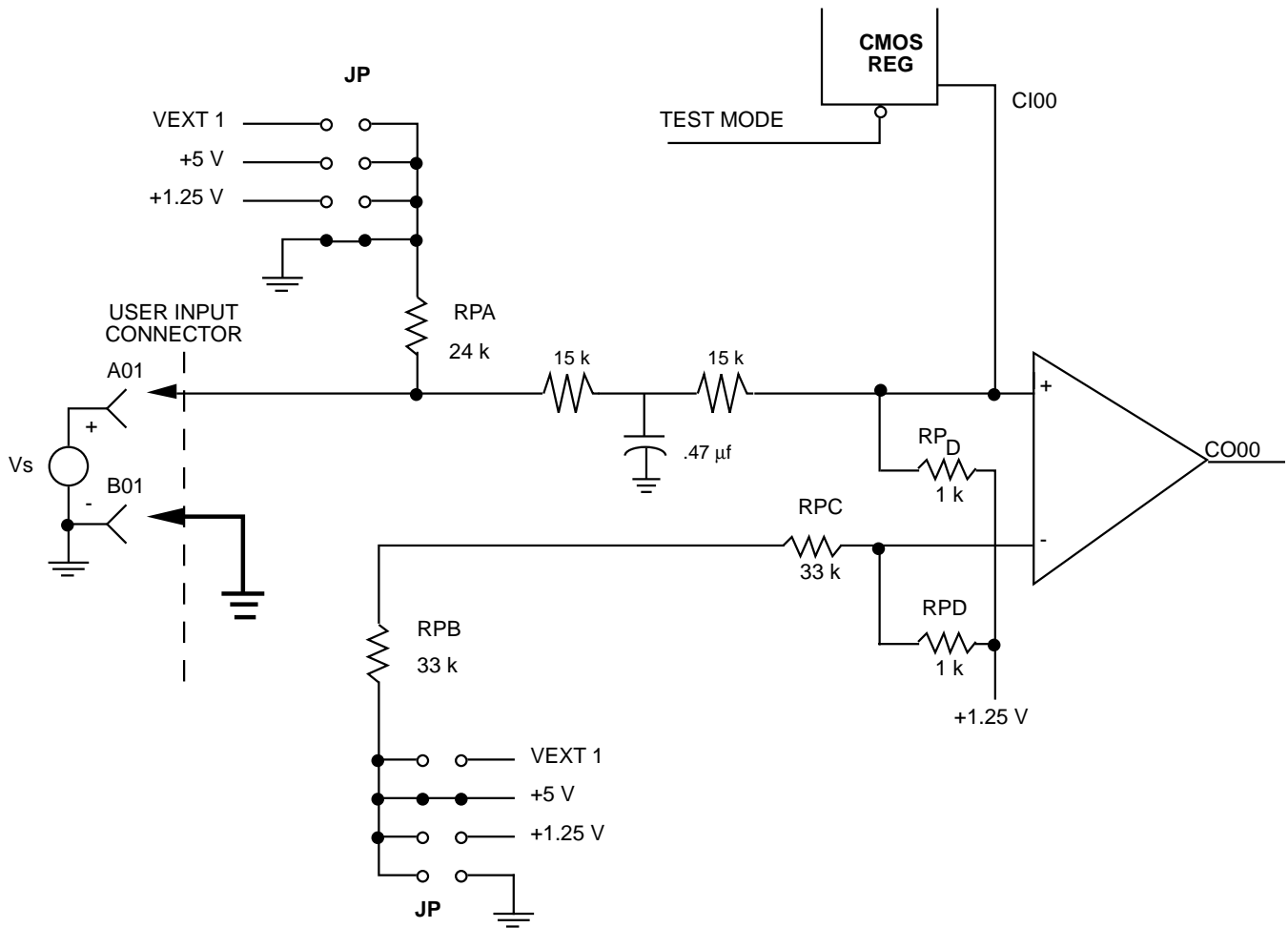

Figure 4. Input Configuration for Voltage Sourcing Inputs

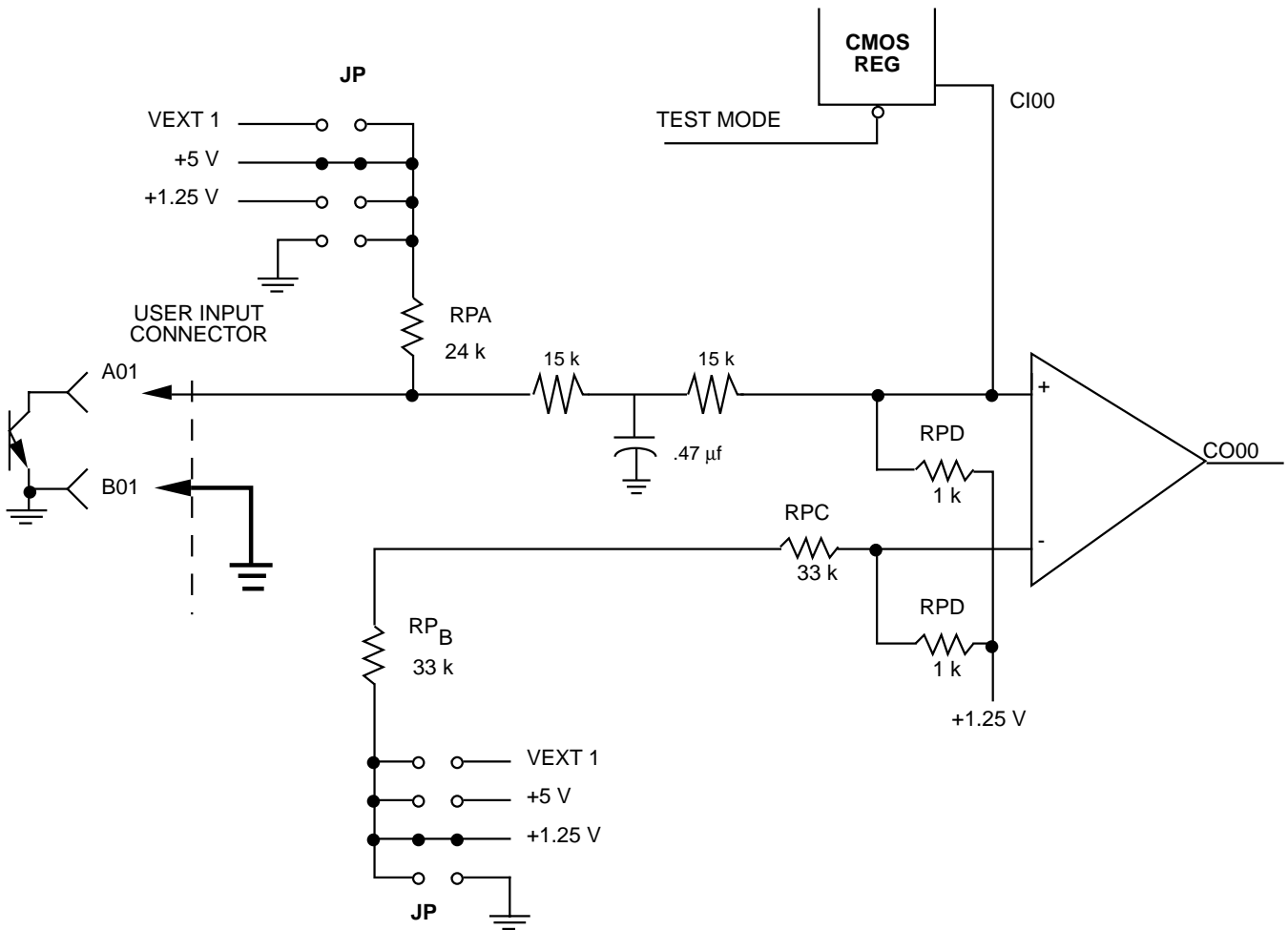

Figure 5. Input Configuration for Current Sinking Inputs

Table 1. Threshold Voltages

$$V_t = 0.46 \text{ V} + 0.67$$

| V | V _t |
|--------|----------------|
| 0 V | 0.67 V |
| 1.25 V | 1.25 V |
| 5 V | 3.0 V |
| 12 V | 6.2 V |
| 24 V | 11.7 V |
| 28 V | 13.6 V |
| 48 V | 22.8 V |
| 66 V | 31.0 V |