

# FPM-3191G

## Industrial 19" Flat Panel Monitor with Direct-VGA Port

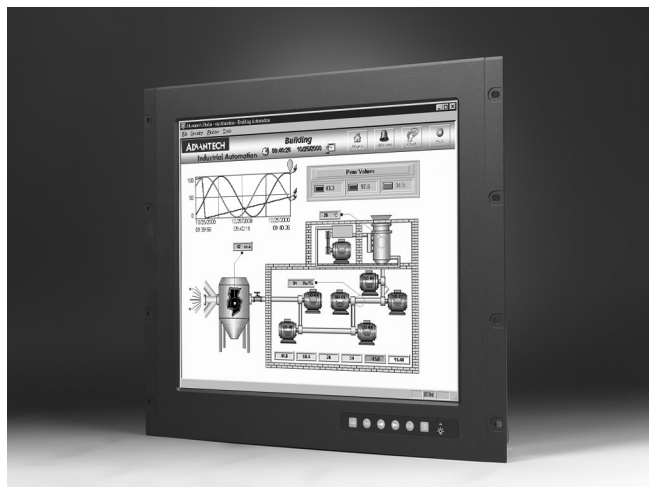

### Features

- 19" SXGA TFT LCD with resolution up to 1280 X 1024
- Stainless steel chassis with NEMA4/IP65-compliant aluminum front panel (optional stainless steel front panel available)
- Multi-scan function supports SXGA, XGA, SVGA, VGA, text mode
- Auto-recognition of input signal
- Supports panel, wall, desktop, rack mount or VESA arm mounting
- Anti-reflective screen with tempered glass
- Hard anodic coating to prevent panel abrasion and acid corrosion

### Introduction

FPM-3191G is a 19" color TFT LCD flat panel monitor specifically designed for industrial applications. With a viewing size as large as 19", it presents an ample display area as well as vivid and sharp images for your HMI. It features Direct-VGA signal transmission and the on-screen display function makes it easy to adjust the images on the screen. The stainless steel chassis and the NEMA4/IP65 compliant aluminum front

### Specifications

#### General

- **Button Controls** OSD control pad on front panel
- **Certifications** BSMI, CCC, CE, FCC
- **Dimensions (WxHxD)** 482 x 399 x 66 mm (18.9" x 15.7" x 2.6")
- **Enclosure** Aluminum with hard anodic coating, (optional stainless steel)
- **Mounting** Panel, wall, desktop, rack mount or VESA arm
- **Power Input** External 60 W power adapter, with AC 100 V ~ 240 V input and DC +12 V @ 5 A output
- **Video Ports** VGA
- **Weight (Net)** 9.2 kg (20.3 lb)

#### LCD Display

- **Backlight Life** 50,000 hrs
- **Contrast Ratio** 700: 1 (typical)
- **Display Size** 19"
- **Display Type** SXGA TFT LCD
- **Luminance** 300 cd/m<sup>2</sup>
- **Max. Colors** True color (16.2 million)
- **Max. Resolution** 1280 x 1024
- **Viewing Angle (H/V°)** 170/170

#### Touchscreen (Optional)

- **Interface** RS-232
- **Lifespan** 1 million touches at a single point (resistive)  
35 million touches (capacitive)
- **Light Transmission** 79 % (resistive), 88% (capacitive)
- **OS Support** Windows® 98/2000/XP
- **Power Consumption** +5 V @ 200 mA (for -R version)
- **Resolution** 1024 x 1024 (resistive), 4096 x 4096 (capacitive)
- **Type** 8 Wire, analog resistive or capacitive sensor

#### Environment

- **Humidity (Storage)** 5 ~ 90% non-condensing
- **Ingress Protection** Front panel: NEMA4, IP65
- **Operating Temperature** 0 ~ 50° C (32 ~ 122° F)
- **Storage Temperature** -20 ~ 60° C (-4 ~ 140° F)
- **Vibration Protection** 5-500 Hz, 1 Grms (Operating, Random)

### Ordering Information

- **FPM-3191GA** Industrial 19" TFT LCD display with 19" Rack-Mount Bezel, DirectVGA interface and AC 100 ~ 220 V input 60 W power adapter
- **FPM-3191GA-C** FPM-3191GA with capacitive touchscreen (RS-232 interface)
- **FPM-3191GA-R** FPM-3191GA with resistive touchscreen (RS-232 interface)

**Dimensions**

*Unit: mm*

Diameters of the rackmount holes:  
Vertical: 6.5mm  
Horizontal: 9mm

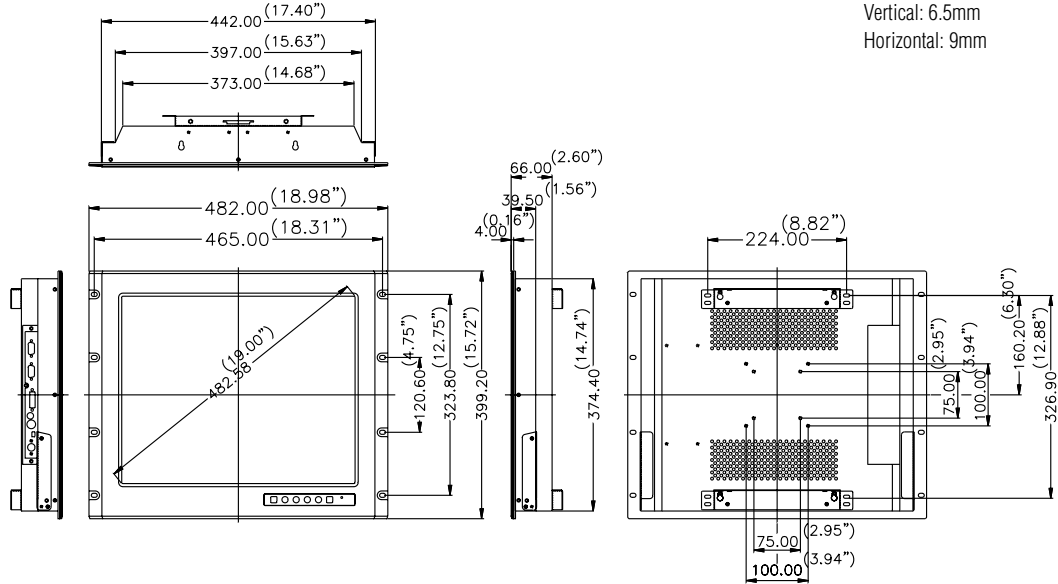

**Cut-off dimension: 444 x 376 mm (17.48" x 14.84")**

**Side View**

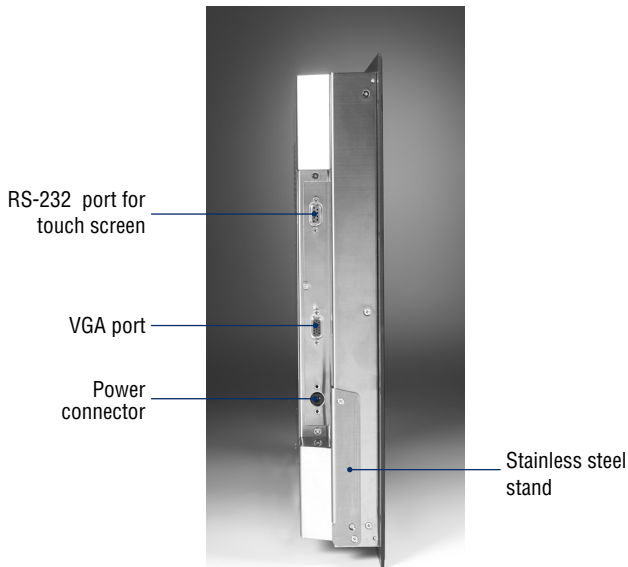

1	Software
2	IPPC
3	TPC
4	FPM
5	ATM & AWS
6	DA&C
7	cPCI
8	ADAM-3000
9	Motion Control
10	ICOM
11	Industrial Networking
12	UNO
13	ADAM-4000
14	ADAM-5000
15	ADAM-6000
16	ADAM-8000
17	BAS