

Express-IA533

COM Express™ Module with Intel® Pentium® M Processor and 915GME/ICH6-M Chipset

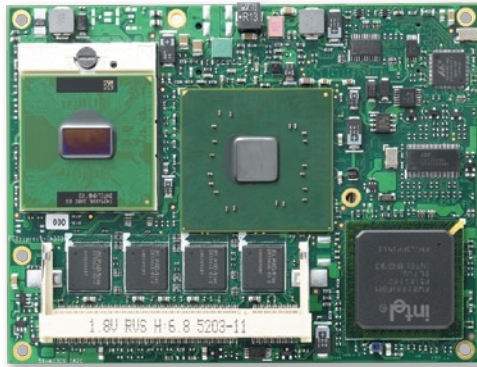

Features

- Intel® Pentium® M Processor up to 2.1 GHz
- Intel® 915GME Express chipset
- Dual-Channel DDR2 533 MHz
- Three PCI Express® x1 lanes and one PCI Express® x16 Graphics lane
- Onboard Gigabit Ethernet
- SATA, USB 2.0, LVDS, SDVO

Specifications

Core System

CPU	Socket 479 type Intel® Pentium® M 760, 2.0 GHz, with 2MB L2 cache Intel® Pentium® M 745, 1.8 GHz, with 2MB L2 cache BGA type Intel® Pentium® M 738, 1.4 GHz, with 2MB L2 cache Intel® Celeron® M 373, 1.0 GHz, with 1MB L2 cache
Memory	400/533 MHz DDR2, non-ECC, unbuffered Channel A: SO-DIMM socket for DDR2 memory, max 1 GB Channel B: soldered DDR2 memory, max 512 MB
Chipset	Intel® 915GME Express Graphic Memory Controller Hub and Intel® I/O Controller Hub 6 Mobile (ICH6-M)
BIOS	Phoenix AWARD BIOS in 1 MB FWH with console redirection and CMOS EEPROM backup
Hardware Monitor	Supply voltages and CPU temperature
Watchdog Timer	Programmable timer ranges to generate RESET
Expansion Busses	Four PCI Express x1 lanes (one occupied by GbE LAN) Six 32-bit PCI 2.3 Masters at 33/66 MHz Low Pin Count (LPC) interface for Super I/O on carrier SMBus 2.0 interface support

Video

Chipset	915GME GMCH integrated chipset supports dual independent displays
CRT Interface	Analog CRT support up to 2048 x1536
LVDS Interface	Dual channel 18-bit
Graphic Expansion busses	One PCI Express® x16 Graphics port Two Serial DVO ports (multiplexed with PCI Express® x16)

Audio

Chipset	Integrated on Intel® ICH6-M
Audio Codec	Optional AC'97 codec on carrier

LAN

Chipset	Yukon-EC 88E8053 PCIe Gigabit Ethernet Controller
Interface	Triple speed 10/100/1000BASE-T IEEE 802.3 compliant with fully integrated ASF 2.0 functionality

Multi I/O

Chipset	Intel® ICH6-M
IDE (PATA)	One Ultra ATA 100/66/33 IDE port
SATA	Two SATA 1.5 Gb/s ports
USB	Up to eight USB 2.0 ports, supports legacy KB / Mouse

Super I/O

Connected to LPC bus on carrier if needed

TPM

Chipset	Infineon SLB9635TT1.2
Type	TPM 1.2

Power Specifications

Input Power	AT mode (12 V) and ATX mode (12 V and 5 Vsb)
Power States	Supports S0, S1, S3, S4, S5
Power Consumption	18 W typical (with Pentium® M 738 and 1 GB memory)

Mechanical and Environmental

Operating Temp.	0°C to 60°C
Storage Temp.	-20°C to 80°C
Humidity	Up to 90% at 60°C
Shock	15G peak-to-peak, 11ms duration, non-operation
Vibration	Non-operating: 1.88 Grms, 5-500 Hz, each axis Operating: 0.5 Grms, 5-500 Hz, each axis
Form Factor	COM Express™ Type 2, Basic form factor, 95 mm x 125 mm
Certifications	CE, FCC

Operating Systems

Standard Support	Windows® XP 32-bit Linux® 2.6.x
Extended Support	Embedded XP BSP Linux® 2.6.x BSP AIDI Library for Win32 and Linux®

Functional Diagram

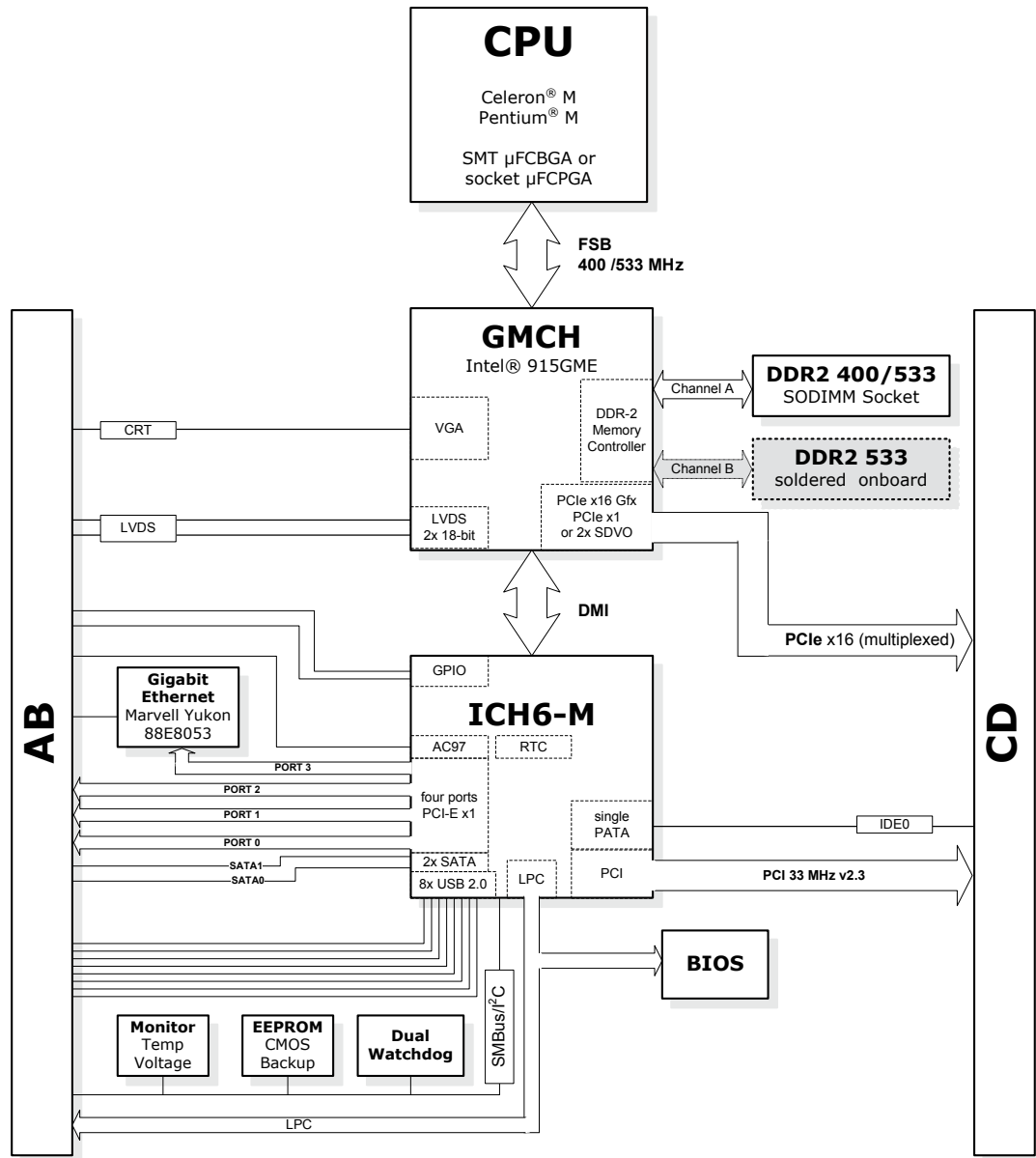

Ordering Information

Modules

Model Number	Description/Configuration
Express-IA533-S/0	COM Express module with socket for Intel® Celeron®/ Pentium® M processor
Express-IA533-760/0	COM Express module with Intel Pentium® M 760 at 2.0GHz
Express-IA533-745/0	COM Express module with Intel Pentium® M 745 at 1.8GHz
Express-IA533-738/0	COM Express module with Intel Pentium® M 738 at 1.4GHz
Express-IA533-373/0	COM Express module with Intel Celeron® M 373 at 1GHz

Note: All models optional soldered memory

Accessories

Model Number	Description/Configuration
Heat Spreaders	
HTS-IA533-B	Heatspreader for Express-IA533 (BGA CPU) with threaded standoffs
Passive Heatsinks	
THS-IA533-B	Low Profile Heatsink for Express-IA533 (BGA CPU) with threaded standoffs
Heatsink with Active Cooling	
THSF-IA533-S	High Performance Heatsink with Fan for Express-IA533 (socket CPU) with threaded standoffs