

Main Features

- ◆ VIA Eden™/C7 with V4 Bus Processors On-board
- ◆ VIA CN700 and 8237 R+ Chipsets
- ◆ 1 x 240-pin DDR2 DIMM Socket Supports Un-buffered Non-ECC DDR2 533/400 up to 1GB
- ◆ 2 x Realtek RTL8110SC Gigabit Ethernet Controller
- ◆ Supports Dual Display by LVDS and VGA
- ◆ CompactFlash Socket

Product Overview

The 5.25" EBC 580E embedded board computer is Based on VIA's new generation of embedded CPUs featuring Eden™ (low power) , C7 (high performance) and also new VIA Nano processor . The EBC 580E incorporates a VIA CN700 and 8237R+ chipset. The VIA CN700 supports un-buffered non-ECC DDR2 533/400 memory up to 1GB and offers a powerful integrated graphics engine.

The South Bridge 8237 R+ chipset provides a standard 32-bit/33 MHz PCI slot, parallel port, 44-pin IDE connector, SATA connector, CompactFlash socket, and numerous other I/O ports such as four serial ports, four USB 2.0 ports, two Gigabit Ethernet LAN ports, an audio interface, as well as others.

The RoHS compliant EBC 580E is the enhancement version from EBC 580, keeping the same mechanical dimensions to share the same chassis with EBC 580board. The EBC 580E has many enhancement compared to the EBC 580, utilizing DDR2 memory, support USB 2.0 and SATA storage, integrated dual Gigabit Ethernet, and supports AT & ATX power supplies. Additionally, the new EBC 580E supports single wide range of LVDS panel ranging from 18-bit to 48-bit panels for cost down purpose.

Specifications

CPU Support

- ◆ VIA Eden™ V4 500 MHz
- ◆ VIA Eden™ V4 1 GHz
- ◆ VIA C7 1.5 GHz
- ◆ VIA Nano compatible

Main Memory

- ◆ 1 x 240-pin DIMM Socket for up to 1GB un-buffered non-ECC DDR2 533/400 memory

Chipset

- ◆ VIA® CN700/VIA® 8237R+

BIOS

- ◆ Award System BIOS
- ◆ Supports Power On after power fail as a BIOS option
- ◆ Supports Wake on LAN
- ◆ 4 Mbit flash ROM

On-board LAN

- ◆ 2 x 10/100/1000 network connection Realtek RTL8110SC
- ◆ Each LAN port reserved with 2-pin header for extended LAN LED (Active, Link 100, and 1000 LAN LED)
- ◆ Supports Wake on LAN (When 5 Vsb power available). (LAN1 is available for Wake up, LAN2 is not available for Wake up)

Audio

- ◆ VIA, VT1613 CODEC for AC97 V 2.0
- ◆ MIC-in, Speaker-out, CD-in, Line-in

Display

- ◆ VIA VT1636 transmitter
- ◆ Analog VGA Interface: 1 x DB15 connector
- ◆ LVDS Interface: 2 x DF13 20-pin LVDS connector for internal connection, supports single (18bit) or dual pixel (36bit) LVDS panel
- ◆ CCFL: 1 x CCFL for LCD panel backlight inverter power

I/O Interface

- ◆ Serial port: 4 ports, with 1x 40 pin header, COM 2 for RS 232/422/485
- ◆ USB 2.0 x 4
- ◆ Parallel port: 1 port, with 2x13 box header (2.0mm)
- ◆ PS/2: 1 x Mini-Din for Keyboard/Mouse
- ◆ Digital I/O: 2x4 pin header (2.54mm)
- ◆ IrDA: on-board pin header for IrDA Tx/Rx
- ◆ SMBus 2.0 controller
- ◆ On-board header for reset SW and HD active LED
- ◆ I2C: On-board 3-pin header for I2C, one pin for GND
- ◆ 1 x DB15 VGA port

Block Diagram

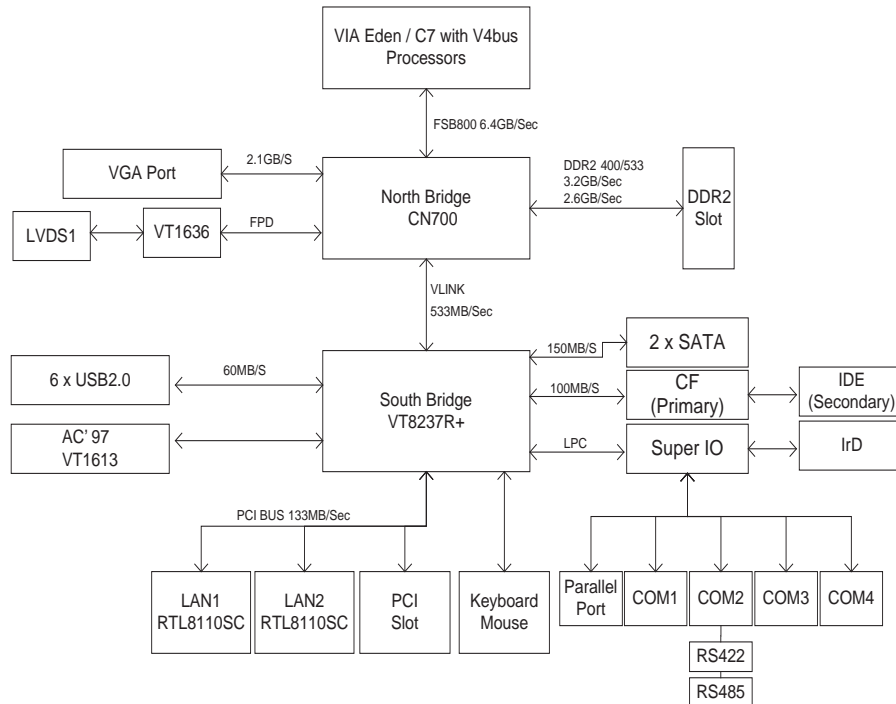

Watchdog Timer

- Watchdog timeout is programmable by software from 1 second to 64 seconds

On-board RTC

- On-chip RTC with battery back up
- 1 x External Lithium battery

Storage

- 1 x CF internal socket
- 1 x 44-pin connector (secondary)

System Monitor

- Derived from Super I/O to support system monitor
- Monitoring of 5 voltages, 3 temperatures and 2 fan speeds.
- 5 voltage (For +3.3 V, +5 V, +12 V, Vcore and +2.5 V)
- 3 temperature (For CPU and two external for system)
- 2 fan speed (one for CPU and one for systems)

Power Input

- 3-pin header for AT/ATX mode switch
- +3.3 V is converted from +5 V
- 6-pin power input connector
- 3-pin Jst connector to receive the 5 Vsb input from power source
- Factory default setting is AT Mode

Power Requirements

CPU: VIA C7 1.5GHz/400MHz; Memory: 1 x DDR2 1GB	+12 V	+5 V
Full-Loading Mode	1.28 A	4.17 A
Light-Loading Mode	0.36 A	1.71 A

NOTE:

Full Loading: Utilize CPU 100% with Burn-in test running
Light Loading: Utilize CPU loading below 5% without application running

ATX Mode

- Power required: +12 V/+5 V/+5 Vsb
- Supports Power On push Button, Software Shutdown function and LAN1 remote wake up only
- 2-pin Header for Power On Push Button

AT Mode

- Power Required: +5 V/+12 V
- No Power On push Button, No Software Shutdown function and No LAN1 remote wake up

Dimensions

- 5.25" form factor 203mm (L) x 146mm (W) (7.9" x 5.7")

Environment

- Board level operating temperature: 0°C to 60°C
- Storage temperature: -20°C to 80°C
- Relative humidity: 10% to 90% (Non-condensing)

Certifications

- CE approval
- FCC Class A

Ordering Information

- **EBC 580E-715 (P/N: 10E00580E00X0)**
Low Power Embedded Board with VIA C7 CPU 1.5 GHz w/ VGA/Single LVDS/Audio/4 COM/4 USB 2.0/Dual Gigabit LAN
- **EBC 580E-E10 (P/N: 10E00580E01X0)**
Low Power Embedded Board with VIA Eden™ V4 Bus CPU 1 GHz w/ VGA/Single LVDS/Audio/4 COM/4 USB 2.0/Dual Gigabit LAN
- **EBC 580E-E05 (P/N: 10E00580E02X0)**
Low Power Embedded Board with VIA Eden™ V4 Bus CPU 500MHz w/ VGA/Single LVDS/Audio/4 COM/4 USB 2.0/Dual Gigabit LAN
- **Packing List**

Part No.	Description
60233MK202X00	PS2 Y CABLE
6023325262X00	PRINT CABLE
6023309402X00	COM CABLE L: 300mm
60233PW145X00	POWER CABLE
60233ATA17X00	SATA CABLE
60233POW20X00	POWER CABLE