

D302 - 6U CompactPCI Card with 128 Binary I/Os



- ◆ 1-slot CompactPCI peripheral board
- ◆ 4 optically isolated units with 32 channels for each unit
- ◆ Individual use of each channel as input or output
- ◆ Individual edge-triggered interrupts
- ◆ Input/output load on ground
- ◆ High-side output switches
- ◆ High output current: max. 1.9A per channel or 16A per unit
- ◆ Over-current and over-temperature protection

The D302 is an input/output CompactPCI target board for 128 binary process signals. The I/Os are divided into four optically isolated units. The card is used for input/output of digital signals with different voltage levels and ground references. For each unit 32 channels are driven to the 44-pin D-Sub connector. Each channel can be either input or output.

The binary inputs/outputs can be universally used in industrial systems. They are optically isolated from the system, which is essential for advanced automotive and industrial applications.

Technical Data

Binary I/Os

- 128 binary signals
 - 4 optically isolated units
 - 32 channels for each unit
- Individual use of each channel as input or output
- Individual edge-triggered interrupts
- Input/output load on ground
- High-side output switches
- High output current
 - Max. 1.9A per channel
 - Max. 16A per unit
- Over-current and over-temperature protection

Output Characteristics

- Output voltage range: 12V..32V
- Output current log. 0: max. 10mA
- Output current log. 1: max. 1.9A
- Switching time for output change: < 200 μ s
- Isolation voltage (optocoupler): 500V DC

Input Characteristics

- Input voltage min.: 0V
- Input voltage max. external supply voltage (12..32V)
- Voltage level log. 0: 0V..6V or open
- Voltage level log. 1: 12V..32V
- Input current log. 1: 2.03mA @ 24V
- Switching threshold: 9.2V @ 0.78mA typ.
- Switching time for input change: min. 33 μ s, max. 44 μ s
- Excess voltage protection: max. +47V

Peripheral Connections

- Via front panel on four shielded 44-pin HD-Sub receptacle connectors

CompactPCI Bus

- CompactPCI peripheral slot
 - PICMG Spec. 2.0 R3.0 compliant
 - 32-bit data bus
 - 33MHz
- V(I/O): +5V
- Concurrent primary and secondary bus operation

Electrical Specifications

- Isolation voltage
 - 500V DC between isolated side and digital side
 - 180V DC between the channels
 - Voltage between the connector shield and isolated ground is limited to 180V using a varistor; AC coupling between connector shield and isolated ground through 47nF capacitor
- Supply voltage/power consumption:

- +5V (4.85V..5.25V), 106mA
- +3.3V (3.0V..3.6V), 27mA
- +24V (external supply voltage 12..32V), 78mA (total for all units)
- MTBF: 129,000h @ 50°C

Mechanical Specifications

- Dimensions: standard double Eurocard, 233.3mm x 160mm
- Weight: 324g

Environmental Specifications

- Temperature range (operation):
 - 0..+60°C or -40..+85°C
 - Airflow: min. 10m³/h
- Temperature range (storage): -40..+85°C
- Relative humidity range (operation): max. 95% without condensation
- Relative humidity range (storage): max. 95% without condensation
- Altitude: -300m to + 3,000m
- Shock: 15g/0.33ms, 6g/6ms
- Vibration: 1g/5..2,000Hz

Safety

- PCB manufactured with a flammability rating of 94V-0 by UL recognized manufacturers

EMC

- Tested according to EN 55022 / 1999-05 (radio disturbance) and EN 55024 / 1999-05 (immunity) with regard to CE conformity

Software Support

- MEN Driver Interface System (MDIS for Windows, Linux, VxWorks, QNX, RTX, OS-9)

Diagram

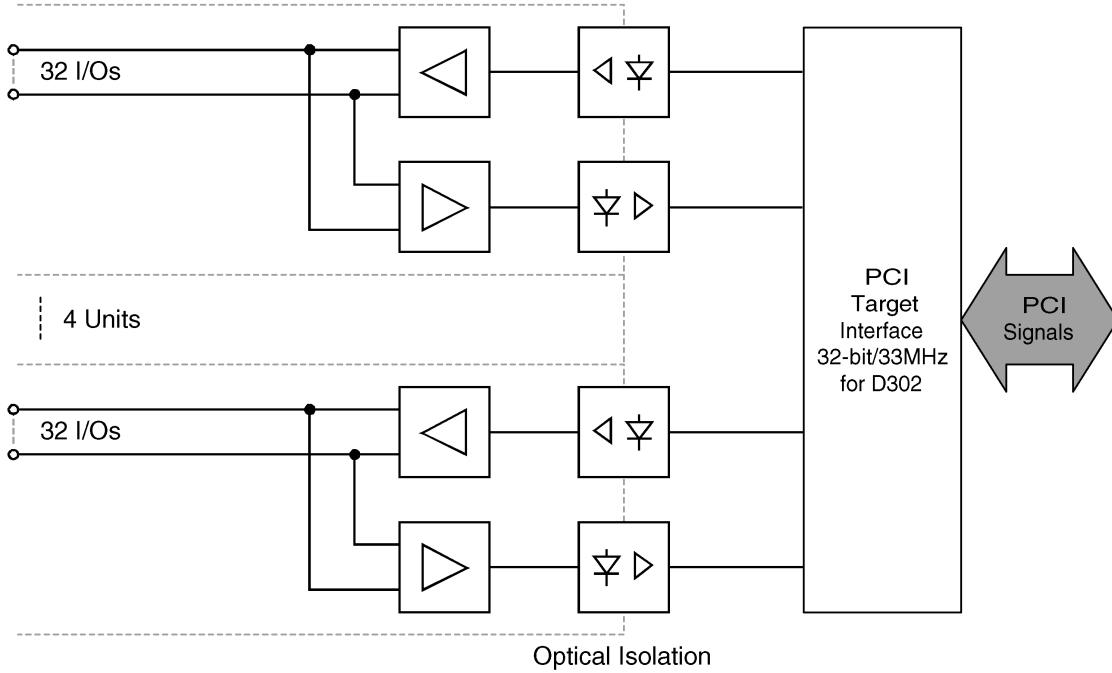

Related Products

Standard Hardware

02D302-00	D302, CompactPCI 6U, 128-bit binary I/O controller, temperature range 0..+60°C
02D302-01	D302, CompactPCI 6U, 128-bit binary I/O controller, temperature range -40..+85°C

Accessories

05M000-14	M-Module cable, 2.5m, with 44-pin HD-Sub plug/housing to pig tail
05M000-20	M-Module cable, 2m with 44-pin HD-Sub plug/housing to 44-pin HD-Sub plug/housing, (connecting 1:1)
05M000-25	M-Module cable, 2m, with 44-pin half-pitch D-Sub plug/housing to 50-pin D-Sub receptacle/housing, (connecting 1:1)

Software

13M066-06	MDIS4/2004 low-level driver sources for M66/A302/D302
13M066-70	MDIS4/2004 Windows NT4/W2K driver for M66/A302/D302

To use MDIS4 low-level drivers, you also need one of the MDIS4 system packages available for Windows, Linux, VxWorks, QNX, RTX or OS-9 (MDIS4 = MEN Driver Interface System).

Documentation

20APPN001	Application Note: Using MEN +5V CompactPCI Boards with +3.3V V(I/O)
20D302-00	D302 user manual

For the most up-to-date ordering information and direct links to other data sheets and downloads, see the [D302 online data sheet under www.men.de](http://www.men.de). --> [Click here!](#)

Contact Information

Germany

MEN Mikro Elektronik GmbH
 Neuwieder Straße 5-7
 90411 Nuremberg
 Phone +49-911-99 33 5-0
 Fax +49-911-99 33 5-901
 E-mail info@men.de
 www.men.de

France

MEN Mikro Elektronik SA
 18, rue René Cassin
 ZA de la Châtelaine
 74240 Gaillard
 Phone +33 (0) 450-955-312
 Fax +33 (0) 450-955-211
 E-mail info@men-france.fr
 www.men-france.fr

UK

MEN Micro Ltd
 Whitehall, 75 School Lane
 Hartford, Northwich
 Cheshire UK, CW8 1PF
 Phone +44 (0) 1477-549-185
 Fax +44 (0) 1477-549-178
 E-mail info@menmicro.co.uk
 www.menmicro.co.uk

USA

MEN Micro, Inc.
 PO Box 4160
 Lago Vista, TX 78645-4160
 Phone (512) 267-8883
 Fax (512) 267-8803
 E-mail sales@menmicro.com
 www.menmicro.com

The date of issue stated in this data sheet refers to the Technical Data only. Changes in ordering information given herein do not affect the date of issue.

All brand or product names are trademarks or registered trademarks of their respective holders.

Information in this document has been carefully checked and is believed to be accurate as of the date of publication; however, no responsibility is assumed for inaccuracies. MEN Mikro Elektronik accepts no liability for consequential or incidental damages arising from the use of its products and reserves the right to make changes on the products herein without notice to improve reliability, function or design. MEN Mikro Elektronik does not assume any liability arising out of the application or use of the products described in this document.

The products of MEN Mikro Elektronik are not suited for use in nuclear reactors and for application in medical appliances used for therapeutical purposes.

Application of MEN's products in such plants is only possible after the user has precisely specified the operation environment and after MEN Mikro Elektronik has consequently adapted and released the product.

Copyright © 2004 MEN Mikro Elektronik GmbH. All rights reserved.