

## Super-mini Signal Conditioners Mini-M Series

### LIMITER

#### Functions & Features

- Prevents DC output signals from going above or below preset values
- High and low limits independently adjustable from -10.0 % to +105 %
- Easy high/low limit setting with the front digital display
- CE marking
- UL approval

#### Typical Applications

- Protecting the receiving instrument which could malfunction with an overscale input
- Securing the minimum fuel flow in a combustion control loop

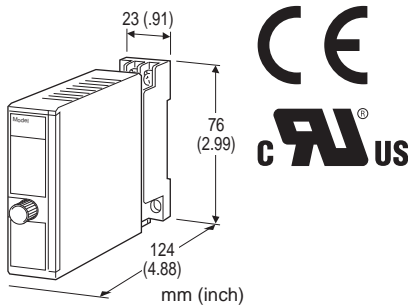

### MODEL: M2LMS-[1][2]-[3][4]

#### ORDERING INFORMATION

- Code number: M2LMS-[1][2]-[3][4]  
Specify a code from below for each [1] through [4].  
(e.g. M2LMS-6A-M2/CE/Q)
- Special input and output ranges (For codes Z & 0)
- Specify the specification for option code /Q  
(e.g. /C01/S01)

#### [1] INPUT

##### Current

- A: 4 - 20 mA DC (Input resistance 250 Ω)
- A1: 4 - 20 mA DC (Input resistance 50 Ω)
- B: 2 - 10 mA DC (Input resistance 500 Ω)
- C: 1 - 5 mA DC (Input resistance 1000 Ω)
- D: 0 - 20 mA DC (Input resistance 50 Ω)
- E: 0 - 16 mA DC (Input resistance 62.5 Ω)
- F: 0 - 10 mA DC (Input resistance 100 Ω)
- G: 0 - 1 mA DC (Input resistance 1000 Ω)
- H: 10 - 50 mA DC (Input resistance 100 Ω)
- J: 0 - 10 μA DC (Input resistance 1000 Ω)

- K: 0 - 100 μA DC (Input resistance 1000 Ω)
- GW: -1 - +1 mA DC (Input resistance 1000 Ω)
- FW: -10 - +10 mA DC (Input resistance 100 Ω)
- Z: Specify current (See INPUT SPECIFICATIONS)

##### Voltage

- 1: 0 - 10 mV DC (Input resistance 10 kΩ min.)
- 15: 0 - 50 mV DC (Input resistance 10 kΩ min.)
- 16: 0 - 60 mV DC (Input resistance 10 kΩ min.)
- 2: 0 - 100 mV DC (Input resistance 100 kΩ min.)
- 3: 0 - 1 V DC (Input resistance 1 MΩ min.)
- 4: 0 - 10 V DC (Input resistance 1 MΩ min.)
- 5: 0 - 5 V DC (Input resistance 1 MΩ min.)
- 6: 1 - 5 V DC (Input resistance 1 MΩ min.)
- 4W: -10 - +10 V DC (Input resistance 1 MΩ min.)
- 5W: -5 - +5 V DC (Input resistance 1 MΩ min.)
- 0: Specify voltage (See INPUT SPECIFICATIONS)

#### [2] OUTPUT

##### Current

- A: 4 - 20 mA DC (Load resistance 750 Ω max.)
- B: 2 - 10 mA DC (Load resistance 1500 Ω max.)
- C: 1 - 5 mA DC (Load resistance 3000 Ω max.)
- D: 0 - 20 mA DC (Load resistance 750 Ω max.)
- E: 0 - 16 mA DC (Load resistance 900 Ω max.)
- F: 0 - 10 mA DC (Load resistance 1500 Ω max.)
- G: 0 - 1 mA DC (Load resistance 15 kΩ max.)
- Z: Specify current (See OUTPUT SPECIFICATIONS)

##### Voltage

- 1: 0 - 10 mV DC (Load resistance 10 kΩ min.)
- 2: 0 - 100 mV DC (Load resistance 100 kΩ min.)
- 3: 0 - 1 V DC (Load resistance 1000 Ω min.)
- 4: 0 - 10 V DC (Load resistance 10 kΩ min.)
- 5: 0 - 5 V DC (Load resistance 5000 Ω min.)
- 6: 1 - 5 V DC (Load resistance 5000 Ω min.)
- 4W: -10 - +10 V DC (Load resistance 10 kΩ min.)
- 5W: -5 - +5 V DC (Load resistance 5000 Ω min.)
- 0: Specify voltage (See OUTPUT SPECIFICATIONS)

#### [3] POWER INPUT

##### AC Power

- M2: 100 - 240 V AC (Operational voltage range 85 - 264 V, 47 - 66 Hz)  
(90 - 264 V for UL)

##### DC Power

- R: 24 V DC  
(Operational voltage range 24 V ±10 %, ripple 10 %p-p max.)
- R2: 11 - 27 V DC  
(Operational voltage range 11 - 27 V, ripple 10 %p-p max.)  
(Select '/N' for 'Standards & Approvals' code.)
- P: 110 V DC  
(Operational voltage range 85 - 150 V, ripple 10 %p-p max.)

(110 V  $\pm$ 10 % for UL)

## [4] OPTIONS (multiple selections)

### STANDARDS & APPROVALS (must be specified)

/N: Without CE or UL

/CE: CE marking

/UL: UL approval (CE marking)

### OTHER OPTIONS

blank: none

/Q: Option other than the above (specify the specification)  
(UL not available)

### SPECIFICATIONS OF OPTION: Q (multiple selections)

#### COATING (For the detail, refer to M-System's web site.)

/C01: Silicone coating

/C02: Polyurethane coating

/C03: Rubber coating

#### TERMINAL SCREW MATERIAL

/S01: Stainless steel

## GENERAL SPECIFICATIONS

**Construction:** Plug-in

**Connection:** M3 screw terminals (torque 0.8 N·m)

**Housing material:** Flame-resistant resin (black)

**Isolation:** Input to output to power

**Overrange output:** Approx. -10 to +105 % at 1 - 5 V

**Zero adjustment:** -5 to +5 % (front)

**Span adjustment:** 95 to 105 % (front)

**Limit adjustments:** High and low independently adjustable from -10.0 - +105 %; 0.1 % increments (1 % increments over 100 %)

**High/low selector:** Double-throw SW (front)

**UP/DOWN control:** Double-throw, momentary SW (front)

#### ■ INDICATORS

**High/low digital display:** Red LED; 6.4 mm (.25") 7 segment, 3 digits

**Polarity indicator:** Dual color (red/green) LED; Red with a positive set value; Green with a negative set value.

**Power saving mode:** Indicators turn off if the switches are untouched for 1 minute.

## INPUT SPECIFICATIONS

### • DC Current:

Shunt resistor attached to the input terminals (0.5 W)

Specify input resistance value for code Z.

### • DC Voltage: -30 - +30 V DC

**Minimum span:** 3 mV

**Offset:** Max. 1.5 times span

### Input resistance

Span 3 - 10 mV :  $\geq$  10 k $\Omega$

Span 10 - 100 mV :  $\geq$  10 k $\Omega$

Span 0.1 - 1 V :  $\geq$  100 k $\Omega$

Span  $\geq$  1 V :  $\geq$  1 M $\Omega$

## OUTPUT SPECIFICATIONS

### • DC Current: 0 - 20 mA DC

**Minimum span:** 1 mA

**Offset:** Max. 1.5 times span

**Load resistance:** Output drive 15 V max.

### • DC Voltage: -10 - +12 V DC

**Minimum span:** 5 mV

**Offset:** Max. 1.5 times span

**Load resistance:** Output drive 1 mA max.; at  $\geq$  0.5 V

## INSTALLATION

### Power Consumption

#### • AC Power input:

Approx. 3 VA at 100 V

Approx. 4 VA at 200 V

Approx. 5 VA at 264 V

#### • DC Power input: Approx. 3 W

**Operating temperature:** -5 to +55°C (23 to 131°F)

**Operating humidity:** 30 to 90 %RH (non-condensing)

**Mounting:** Surface or DIN rail

**Weight:** 150 g (0.33 lbs)

## PERFORMANCE in percentage of span

**Accuracy:**  $\pm$ 0.2 %

**Setting accuracy:**  $\pm$ 0.2 %

**Temp. coefficient:**  $\pm$ 0.015 %/°C ( $\pm$ 0.008 %/°F)

**Response time:**  $\leq$  0.5 sec. (0 - 90 %)

**Line voltage effect:**  $\pm$ 0.1 % over voltage range

**Insulation resistance:**  $\geq$  100 M $\Omega$  with 500 V DC

**Dielectric strength:** 2000 V AC @1 minute (input to output to power to ground)

## STANDARDS & APPROVALS

### CE conformity:

EMC Directive (2004/108/EC)

EN 61000-6-4 (EMI)

EN 61000-6-2 (EMS)

Low Voltage Directive (2006/95/EC)

EN 61010-1

Installation Category II

Pollution Degree 2

Max. operating voltage 300 V

Input or output to power: Reinforced insulation

Input to output: Basic insulation

### Approval:

UL/C-UL nonincendive Class I, Division 2,

Groups A, B, C, and D hazardous locations  
 (ANSI/ISA-12.12.01, CAN/CSA-C22.2 No.213)  
 UL/C-UL general safety requirements  
 (UL 61010B-1, CAN/CSA-C22.2 No.1010-1)

## FRONT VIEW

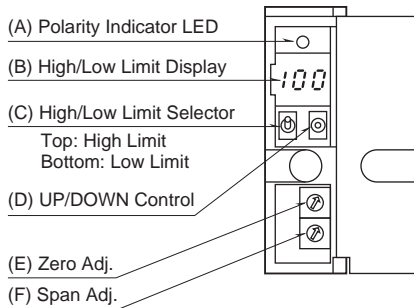

The front cover cannot be turned open by 180 deg. when there is no extra space between units.

### • How to Set High Limit

Turn the High/Low Limit Selector (C) to the top.  
 The High/Low Limit Display (B) shows the current high limit (-10.0 - +105 %). Press UP/DOWN Control (D) until the display shows a desired set value.  
 The Polarity Indicator LED (A) is red when the set value is in positive range, green when in negative range.  
 The high limit is factory set to 100 %.

### • How to Set Low Limit

Turn the High/Low Limit Selector (C) to the bottom.  
 The High/Low Limit Display (B) shows the current low limit (-10.0 - +105 %). Press UP/DOWN Control (D) until the display shows a desired set value.  
 The Polarity Indicator LED (A) is red when the set value is in positive range, green when in negative range.  
 The low limit is factory set to 0 %.

## DIMENSIONS unit: mm (inch)

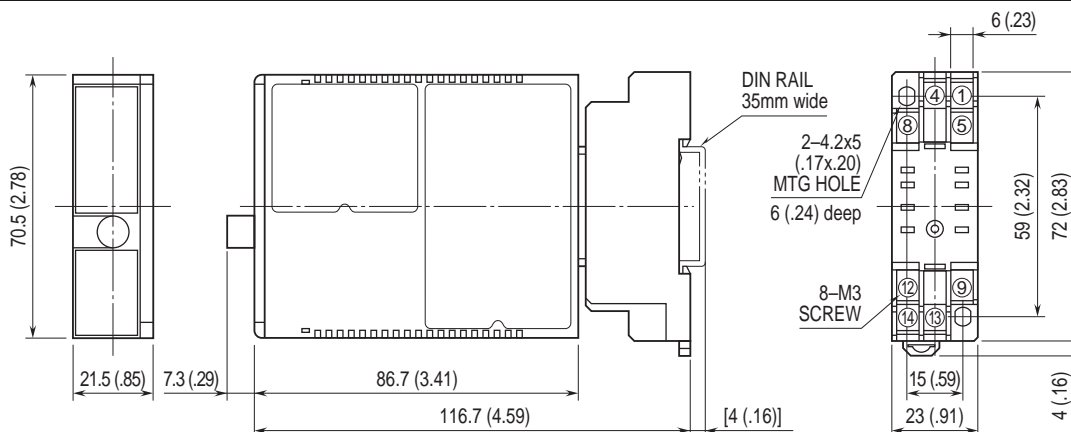

• When mounting, no extra space is needed between units.

**TERMINAL ASSIGNMENTS unit: mm (inch)**

INPUT RESISTOR  
(model: REM2)

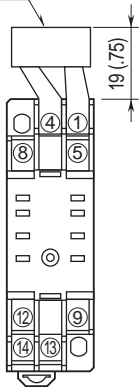

Input shunt resistor attached for current input.

**SCHEMATIC CIRCUITRY & CONNECTION DIAGRAM**

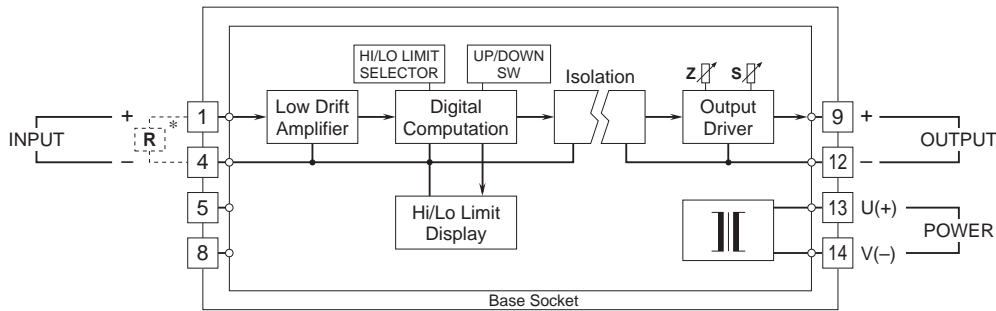

\*Input shunt resistor attached for current input.



Specifications are subject to change without notice.