

### FEATURES

- IEEE 802.3 Ethernet controller board
- 10Mbps operation, CSMA/CD
- Integrated AUI and 10Base-T interfaces (PCM-NE2000)
- 10Base2 thin coax interface (PCM-NE2000-BNC)
- Supports NE2000 and shared memory architecture
- 8- or 16-bit PC/104 interface with no Wait States
- Software configurable settings for jumperless, auto-configurable, "easy-to-use" network designs
- EPROM socket for auto-boot applications
- Five LEDs onboard for visual status information
- Network Operating System compatibility with inherent driver support for NetWare™ Lan Manager™ LANtastic™ FTP, TC/PIP and other popular software
- Diagnostic loopback support provides for increased testability
- Single +5 volt power for 10Base2 and 10Base-T only

The PCM-NE2000 module is a NE2000 compatible local area network adapter board designed for PC/104 expandable systems. As a result, most network operating systems, drivers and utilities for using Ethernet in a PC-compatible environment can be used without modification.

It conforms to the IEEE 802.3 and Ethernet standards for a 10Mbps Carrier Sense Multiple Access/Collision Detection (CSMA/CD) local area network. The PCM-NE2000 module provides connectivity for both an AUI and 10Base-T twisted-pair on a single board. The PCM-NE2000-16-BNC supports 10Base2.

### FUNCTIONAL CAPABILITY

**PC/104 Interface** - The PCM-NE2000 module is designed to offer a flexible, high performance networking capability for the PC/104 bus. It is available with either an 8-bit (PCM-NE2000-8) or 16-bit (PCM-NE2000-16) interface to match the data path width with the host CPU capability.

Multiple PCM-NE2000 boards can be installed and supported on a single PC/104 embedded PC.

**Ethernet Controller** - The PCM-NE2000 module uses a 8390 compatible integrated controller. Supported interfaces include 10Base5 Ethernet via an external transceiver connected to its AUI port and Twisted-pair Ethernet (10Base-T) using the on-board transceiver. The Ethernet controller chip provides the Ethernet Media Access Control (MAC), Encoder-Decoder (ENDEC) with

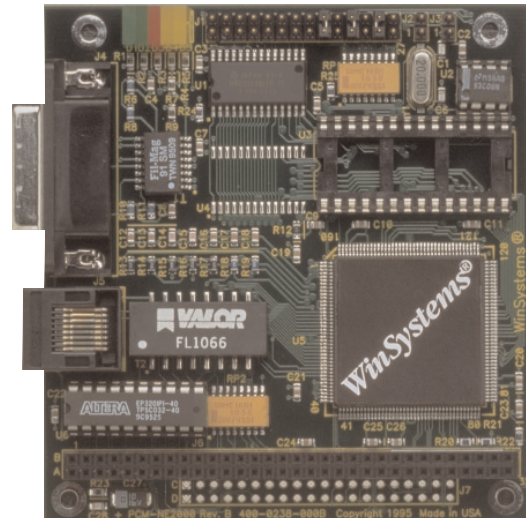

an AUI interface, and 10Base-T transceiver functions in accordance with the IEEE 802.3 standards.

The controller's integrated 10Base-T transceiver fully complies with the IEEE standard. This chip incorporates the receiver, transmitter, collision, heartbeat, loopback, jabber, and link integrity blocks as defined in the standard. The transceiver combined with the PCM-NE2000 module's equalization resistors, transmit/receive filters, and pulse transformers provides a complete physical interface.

Selectable hardware and software options allow the controller's bus interface to be configured for compatibility with either the NE2000 or a shared memory architecture. The NE2000 mode (also known as I/O mode) utilizes a data port register through which all transfers to/from the buffer RAM take place. Any transfer requires the buffer RAM address, transfer size and direction to be programmed into registers before the transfer can be initiated.

In Shared Memory mode the buffer RAM is mapped into system memory. This allows any data in the buffer RAM to be directly transferred across the PC/104 Bus.

**Packet RAM** - Two onboard 32Kbyte SRAMs provide the memory for buffering received packets and for the system to use for buffering transmit packets. The PCM-NE2000 can access up to 64Kbytes; however, the NetWare standard is to only use 16Kbytes of this area.

**EPROM Socket** - A socket is provided to support a user installed 32Kbyte device for auto-boot software

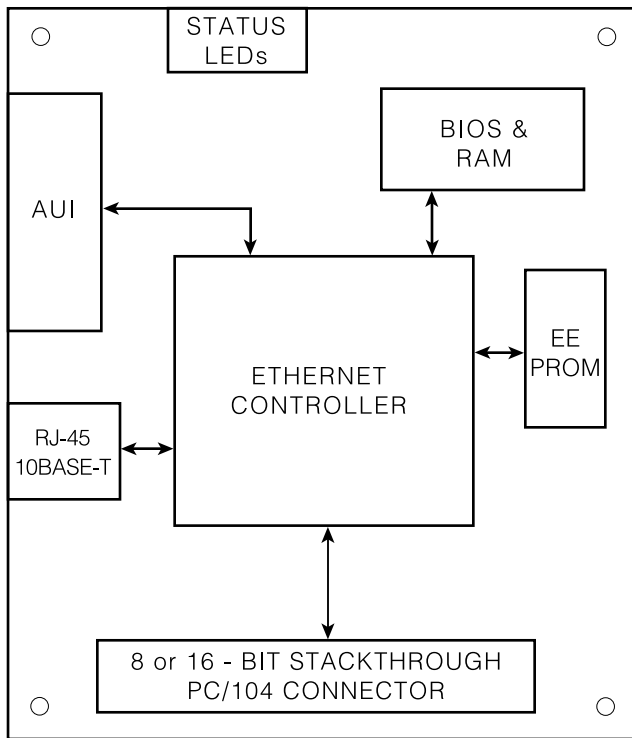

PCM-NE2000 BLOCK DIAGRAM

drivers. It is memory mapped with 4 selectable addresses and is designed for an 8-bit wide memory device.

**EEPROM** - The configuration information describing the device's architecture, address, interrupt, etc. can either be loaded from jumpers or from an EEPROM. The module is shipped with the EEPROM programmed and enabled so that no jumpers need to be installed by the user.

**Interrupts** - The PCM-NE2000-8 supports IRQ channels 3, 4, and 5 for the 8-bit PC/104 bus and the PCM-NE2000-16 supports channels 3, 4, 5, 9, 10, 11, 12, and 15 for the 16-bit PC/104.

**Ethernet Network Connection** - The PCM-NE2000 is connected to the network through customer supplied commercially available transceivers and attachment unit interface (AUI) cables. The module provides +12 volt line to power the transceivers via the AUI connector. The PCM-NE2000 also supports the use of unshielded twisted pair cable so that it can plug into a concentrator in a 10Base-T network.

A second version of this card is available that supports 10Base2 thin coax. Called the PCM-NE2000-16-BNC, it



has the same basic features with the exception of the Ethernet network interface.

**Monitor LEDs** - LEDs are on the PCM-NE2000 to provide a visual status of the module. The green Transmit and Receive LEDs light when the module is transmitting data to or receiving data from the network. The yellow Link Integrity LED lights when there is a valid connection to a 10Base-T concentrator and the yellow Board Select LED lights when the module is selected. The red LED lights when a collision is detected.

**Software** - The board emulates one of the most popular Ethernet Adapter architectures - Novell's NE2000 adapter. This means that most PC-compatible drivers, utilities and Ethernet supported operating systems will work directly with this module.

**OEM Configurations** - Contact the factory for custom configurations and extended temperature operation.

## SPECIFICATIONS

### Electrical

PCM-NE2000-8:	8-bit stackthrough PC/104
PCM-NE2000-16:	16-bit stackthrough PC/104
PCM-NE2000-16-BNC:	16-bit stackthrough PC/104
Data rate:	10 megabits per second
Protocol:	CSMA/CD
Memory socket:	Accepts 27C256 EPROM or equiv.

### Power Requirements

Vcc = +5V ±5% @ 100mA	(typ. for PCM-NE2000-16)
Note: The AUI interface transceiver requires +12V, refer to the adapter manufacturer's specification for current requirements.	
Vcc = +5V ±5% @ 350mA	(typ. for PCM-NE2000-16-BNC)

### Mechanical

Dimensions: 3.6" x 3.8" (90mm x 96mm)

### Connectors

Twisted Pair:	RJ-45 (PCM-NE2000)
AUI:	DB-15F (PCM-NE2000)
Coax:	BNC for RG58/U (PCM-NE2000-16-BNC)

### Environmental

Operating Temperature:	-40° to +85° Celsius
Non-condensing relative humidity:	5% to 95%

## ORDERING INFORMATION

PCM-NE2000-8	8-bit, Ethernet LAN card
PCM-NE2000-8-BNC	8-bit, 10Base 2 Ethernet card
PCM-NE2000-16	16-bit, Ethernet LAN card
PCM-NE2000-16-BNC	16-bit, 10Base2 Ethernet card