

Installation Instructions

Size 25 Absolute Encoder, Bulletin 845D

IMPORTANT: SAVE THESE INSTRUCTIONS FOR FUTURE USE.

Specifications

Electrical	
Code Format	Binary Coded Decimal (BCD) Gray Code Natural Binary
Resolution	(Gray and Natural Binary): 256 CPR (8 bit); 512 CPR (9 bit) 1024 CPR (10 bit) (BCD): 360 CPR (10 bit); 1000CPR (12 bit)
Accuracy	±1 bit
Frequency Response	16K words/sec
Power Requirements	Determined by catalog number: 5V DC ±5% @ 400mA maximum 8-24V DC @ 400mA maximum
Output Drive Capability	NPN current sink = 16mA
Output Logic	Parallel BCD, GRAY, or NAT BIN: Logic "0" = 0.0 to 0.6V DC Logic "1" = 3.5 to 5.0V DC (TTL) Logic "1" = 24V DC maximum (Open collector)
Latch Command	Optional with BCD and NAT BIN only: Logic "0" = outputs active (DC common) Logic "1" = outputs latched (+DC or open)
Direction Control	Field selectable for increasing counts (CW or CCW)
Reset	Reset position value to zero (see Reset Pin section on page 2). Only with shaft stationary.
Mechanical	
Starting and Running Torque	2.5 Ncm typical [3.5in-oz]
Shaft Loading	Axial 89N [20lbs]; Radial 178N [40lbs]
Shaft Size	6mm, 10mm, 1/4in, 3/8in diameter
Moment of Inertia	54g-cm ² (0.3oz-in ²)
Slew Speed	5000 RPM
Environmental	
Housing	NEMA Type 4, IP66 (IEC 529); NEMA Type 4X on selected models
Temperature	0°C to +85°C (+32°F to +185°F)—operating -25°C to +90°C (-13°F to +194°F)—storage
Humidity	98%, noncondensing
Shock	50g (11ms duration)
Vibration	20g (58 to 150Hz)
Approximate Ship Weight	0.91kg (2lbs)

Accessories

Description	Catalog Number
High Performance Flexible Coupling	845-FC-*.*
Measuring Wheels	845-MW-A-*
Servo Clamps	845-SC
Pre-Wired Cables	845-CA-D-*
Mating Connectors	845-SCD

Selection

845D — S J D Z 1 4 B D CK 4
a *b* *c* *d* *e* *f* *g* *h* *i*

a

NEMA Rating	
Code	Description
J	NEMA 4
X	NEMA 4X

b

Mounting Configuration	
Code	Description
D	Square Flange
E	70mm Diameter Flange
F	90mm Diameter Flange
G	Metric Servo 48mm B.C.
H	English Servo
J	Metric Servo 42mm B.C.

c

Shaft Options	
Code	Description
A	6mm Diameter
B	10mm Diameter
C	1/4in Diameter
Z	3/8in Diameter
K	6mm w/Flat
L	10mm w/Flat
M	1/4in w/Flat
N	3/8in w/Flat

d

Power Supply Options	
Code	Description
1	5V DC ±5%
2	8-24V DC Unregulated

e

Output Configuration	
Code	Description
4	5V DC TTL Compatible
5	NPN Open Collector 24V DC Max.

f

Latch Options	
Code	Description
A	No Latch
B	Latch (Sink Output Module Compatible)

g

Output Code Type	
Code	Description
D	Binary Coded Decimal
G	Gray Code
N	Natural Binary

h

Resolution	
Code	Description
CW	256
DW	512
FW	1024
CK	360
CN	1000
	Gray Code or Natural Binary
	Binary Coded Decimal

i

Connector Options	
Code	Description
1	Axial Connector (End) without Mate
2	Radial Connector (Side) without Mate
4	Axial Connector (End) with Mate
5	Radial Connector (Side) with Mate



ATTENTION: The shielded cables, output devices, and power supplies must be properly grounded. All National Electric Code and applicable local codes and ordinances must be observed when wiring the system.

Electrical Connections

Pin	Function		
	Gray Code	Natural Binary	BCD (8421)
A	G(0)	2 ⁰	1
B	G(1)	2 ¹	2
C	G(2)	2 ²	4
D	G(3)	2 ³	8
E	G(4)	2 ⁴	10
F	G(5)	2 ⁵	20
G	G(6)	2 ⁶	40
H	G(7)	2 ⁷	80
J	G(8)	2 ⁸	100
K	G(9)	2 ⁹	200
L	MSB Complement	Not Used	400
M	Not Used	Not Used	800
N	Not Used	Not Used	Not Used
P	Not Used	Not Used	Not Used
R	Not Used	Direction Control	Direction Control
S	Reset	Reset	Reset
T	DC Return	DC Return	DC Return
U	Not Used	Latch Control	Latch Control
V	DC+ Input	DC+ Input	DC+ Input

Direction Pin

The Direction Pin can change function with code type. In parallel type Gray Code encoders, its function is Most significant Bit Complement or MSBC for short. In Natural Binary and Binary Coded Decimal encoders, its function is Direction Control.

Direction Control ①

Natural Binary and BCD

A logic "1" (+DC or open) on the direction control pin will produce increasing counts with a counter-clockwise rotation of the shaft. A logic "0" (DC common) on the direction control pin will produce increasing counts with a clockwise rotation of the shaft.

Gray Code (parallel only)

Counterclockwise rotation of the shaft will produce increasing counts. For increasing counts with a clockwise rotation, use the Most Significant Bit Complement Pin instead of the Most Significant Bit Pin. See Electrical Connection table for pin designation.



ATTENTION: For parallel gray code: connecting the MSB or MSBC to +DC will result in permanent damage to the encoder.

Reset Pin

The shaft must be stationary before using the reset function. Connecting the Reset Pin to +DC will reset Natural Binary and BCD position value to zero. Connecting the Reset Pin to +DC will reset Gray Code position value to maximum (e.g., 255, 511, 1023, etc.) if MSBC is used, to zero if MSB is used. The reset function requires a connection to +DC for 0.1 seconds or longer.



ATTENTION: Activating the Reset Pin results in a change of position reading. This can cause unexpected motion which could result in damage to the product, equipment, or personal injury.

Flexible Shaft Couplings

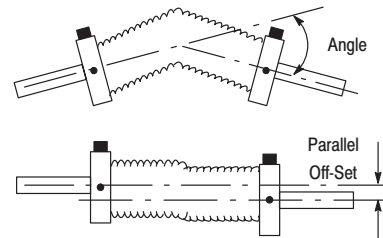

ATTENTION: Rigidly coupling the encoder shaft to the machine shaft **will cause a failure** in either the bearings of the encoder or the bearings of the machine shaft.

① Rotation is viewed from the end of the encoder shaft.

Dimensions—mm (inches)

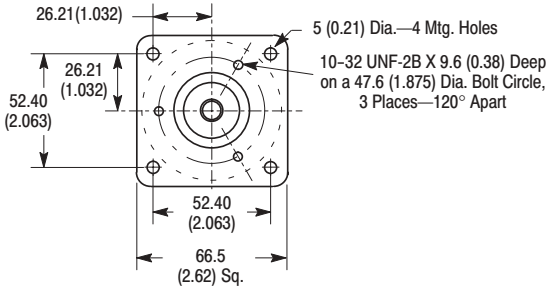
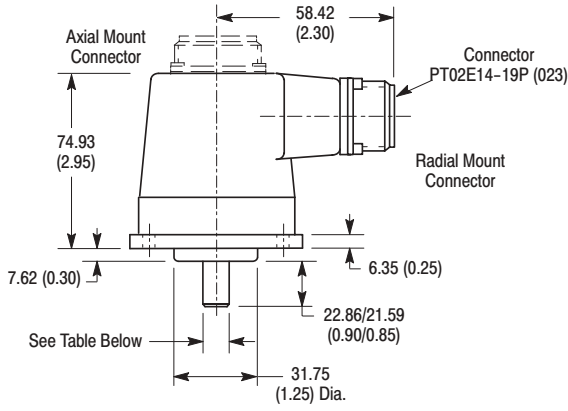

Square Flange Mount

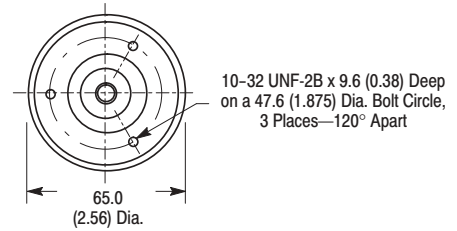
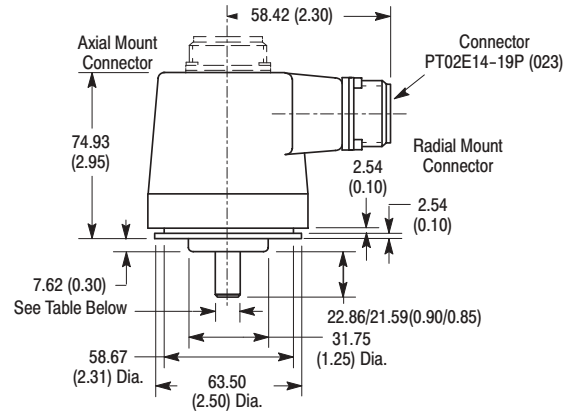

English Servo Mount

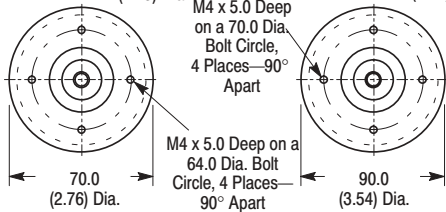
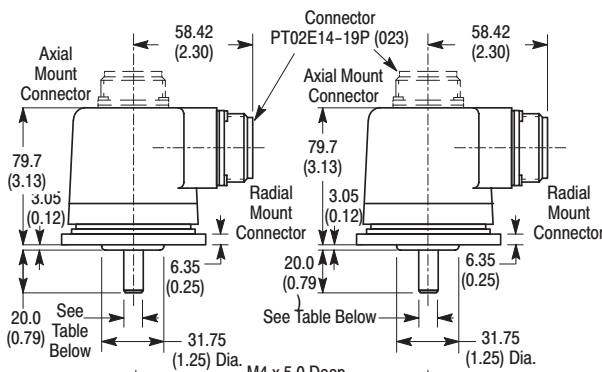

Metric Flange Mount

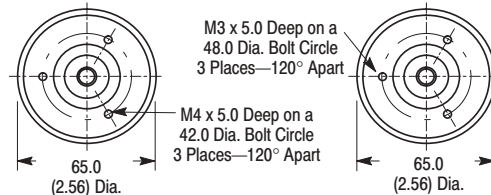
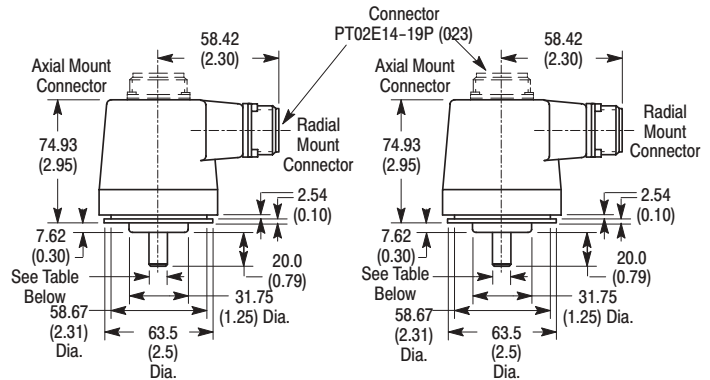

Metric Servo Mount

Shaft Diameter Options

Code	Shaft Diameter
A or K	6mm +0.00mm, -0.013mm
B or L	10mm +0.00mm, -0.013mm
C or M	6.35(0.2499) +0.0000, -0.0005
Z or N	9.52 (0.3749) +0.0000, -0.0005

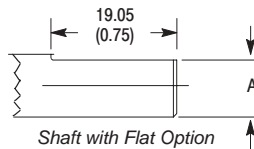

Flat Dimensions

Code	Dimension "A"
K	5.3mm (0.21in)
L	9.1mm (0.36in)
M	5.5mm (0.22in)
N	8.6mm (0.34in)

