

# ICS-8551

## Rugged 4/2-channel, 1.5/3 GHz ADC XMC Module with Virtex-4 FPGA

### Features

- 4 AC-Coupled Analog Inputs
- $F_s \leq 1.5$  GHz 4-channel, or 3 GHz 2-channel (software selectable), 8-bit
- Xilinx Virtex-4 User Programmable FPGA (FX60)
- TCXO @ 10 MHz
- 8-plug Samtec GRF1-J connector (Ruggedization Levels 1, 2 and 3)
- 8 Individual MMCX Coaxial Connectors (Ruggedization Levels 4 and 5)
- PCI 2.2 64-bit, 66 MHz Master/Target Burst Mode DMA capable
- VITA 42 (XMC) high-speed serial interface (single connector, 8 lanes)
- Pn4 LVDS or LVTTTL signal levels
- ANSI/VITA 20-2001 conduction cooled PMC
- VxWorks, Linux and Windows software drivers

The ICS-8551 is a rugged 2 and 4 channel, 1.5/3 GHz ADC XMC module intended for Software Defined Radio (SDR) applications such as communications and radar in benign and hostile environments.

The combination of high performance ADC and FPGA resources allows VHF and UHF signals to be digitized and processed directly on the XMC module. Algorithms such as digital down conversion, FFT, and filtering can be developed to execute in the Virtex-4 FPGA, using the included Hardware Development Kit (HDK). The module is available in five levels of ruggedization, three for air-cooled environments and two for conduction cooled environments. Details of the environmental specifications are available from our web site.

The ICS-8551 HDK includes a default logic core, designed to provide minimum occupancy of the FPGA and to provide a basis for customers to program their own functionality. It includes an A/D interface and data buffering to the high-speed serial outputs and PCI Bus. Functions such as

time-stamping, digital down-conversion, filtering and Fast Fourier Transform can be implemented in the FPGA. For customers not wishing to implement their own DSP functions, we can provide either off-the-shelf DSP functions or our FPGA development team can design and implement specific functions to the customer's specification.

The ICS-8551 provides the user with up to eight lanes of high-speed serial I/O for communication with XMC equipped carrier cards such as the V4DSP at rates up to 3.125 GBytes/s. The 64/66 PCI interface provides sustained data rates in excess of 400 MBytes/s, while the Pn4 user I/O port allows the user to define direct point to point connections to the FPGA, eliminating interrupt latencies. The latter two interfaces may be used for applications in which the XMC interface cannot be used.

The front panel connectors are an 8-plug Samtec GRF1-J connector (for ruggedization levels 1, 2 and 3), or 8 individual MMCX connectors (for ruggedization levels 4 & 5).



# ICS-8551 - Rugged 4/2-channel, 1.5/3 GHz ADC PMC/XMC Module with Virtex-4 FPGA

## Specifications

### Analog Input

- Four AC-coupled analog inputs
- 50 Ohm input impedance
- Software selectable full scale input, 0.236 dBm (650 mVpp) or 2.768 dBm (870 mVpp)
- Input signal bandwidth of 2 MHz -700 MHz (-3 dB point)
- Maximum sample rate of 1.5 GSPS/channel in 4 channel mode or 3.0 GSPS/channel in 2 channel mode
- Minimum sample rate of 200 MSPS
- Internal Sample Clock VCO locked to onboard 10 MHz TCXO or External Source
- Analog to digital resolution 8 bits
- Sampling on rising or falling edge of internal or external sample clock
- External Clock LVTTTL or Sinewave compatible 0 dBm min., 20 dBm max.
- External Trigger LVTTTL
- External Sync LVTTTL
- External User LVTTTL
- SINAD > 40 dB @ 748 MHz input frequency
- SFDR > 45 dB @ 748 MHz input frequency

### General Specifications

- IEEE Std. P1386.1-2001 compatible PCI mezzanine card
- ANSI/VITA 20-2001 conduction-cooled PMC
- VITA 42 XMC compatible (single connector)
- VxWorks, Linux and Windows software device drivers

### Onboard Resources

- Xilinx Virtex-4 FPGA FX60
- TCXO @ 10 MHz
- 8-plug Samtec GRF1-J connector (Ruggedization levels 1, 2 and 3)
- 8 individual MMCX Coaxial connectors (Ruggedization levels 4 and 5)

### I/O Specifications

- PCI 2.2 64-bit, 66 MHz master/target burst mode DMA capable
- XMC interface, two channels, each with four lanes @ 3.125 GBytes/s VITA 42.0-200x
- All 64 user programmable I/O via Pn4 connector routed directly to FPGA
- Pn4 user definable LVDS or LVTTTL signal levels

### Environmental

- Five build levels available. Air and conduction cooled versions
- -40°C to +85°C operating temperature
- 95% non-condensing humidity

## Block Diagram

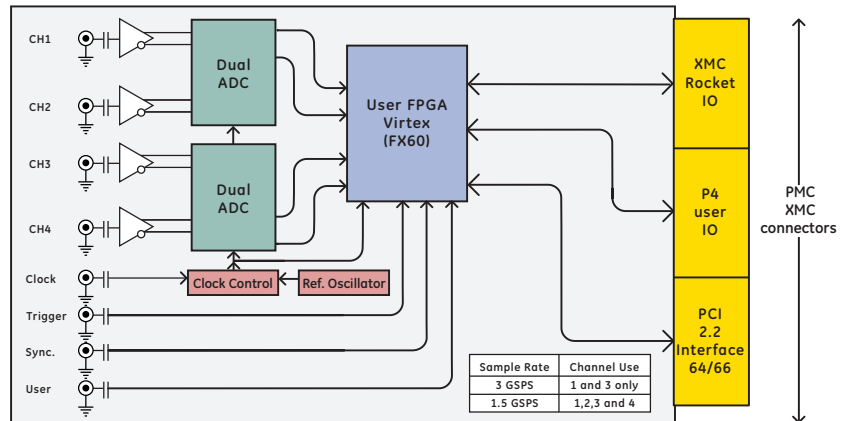

## Ordering Information

### ICS-8551A-xOO

ICS-8551 with Virtex-4 FX60 FPGA

### DRV-8551-VXW

Software device driver for VxWorks operating system

### DRV-8551-LX

Software device driver for Linux operating system

### DRV-8551-WIN

Software device driver for Windows operating system

### DRV-8551-SCA

SCA compliant driver

### HDK-8551

Hardware Development Kit for FPGA development by user, including default core and dual-channel programmable DDC core

## About GE Intelligent Platforms

GE Intelligent Platforms, a General Electric Company (NYSE: GE), is an experienced high-performance technology company and a global provider of hardware, software, services, and expertise in automation and embedded computing. We offer a unique foundation of agile, advanced and ultra-reliable technology that provides customers a sustainable advantage in the industries they serve, including energy, water, consumer packaged goods, government and defense, and telecommunications. GE Intelligent Platforms is a worldwide company headquartered in Charlottesville, VA and is part of GE Home and Business Solutions. For more information, visit [www.ge-ip.com](http://www.ge-ip.com).

## GE Intelligent Platforms Contact Information

Americas: 1 800 433 2682 or 1 434 978 5100

Global regional phone numbers are listed by location on our web site at [www.ge-ip.com/contact](http://www.ge-ip.com/contact)

[www.ge-ip.com/sensorprocessing](http://www.ge-ip.com/sensorprocessing)

