

Space-saving Signal Conditioners M3-UNIT Series

THERMOCOUPLE TRANSMITTER

(field- and PC-configurable)

Functions & Features

- Accepts a thermocouple input and provides an isolated, linearized DC signal
- Easy 'One-Step Cal' calibration using the front three control buttons without needing a PC; PC software is also usable.
- Both input and output type and range are configurable
- Front control button function can be locked
- Cold junction compensation
- Linearization and burnout
- CE marking
- UL approval

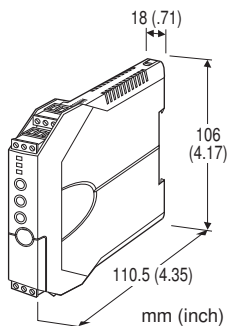
**MODEL: M3LT-R4/[1][2]****ORDERING INFORMATION**

- Code number: M3LT-R4/[1][2]
- Specify a code from below for [1] and [2].
(e.g. M3LT-R4/A)
- Orders will be shipped at default factory settings (K, 0 - 1000°C input/4 - 20 mA output)

INPUT - Field-selectable**Thermocouple**

(PR), K, E, J, T, B, R, S, C (WRe 5-26),
N, U, L, P (Platinel II)

OUTPUT - Field-selectable**Current**

0 - 20 mA DC

Voltage

-2.5 - +2.5 V DC

-10 - +10 V DC

POWER INPUT**DC Power**

R4: 10 - 32 V DC

(Operational voltage range 9 - 36 V, ripple 10 %p-p max.)

[1] CONFIGURATION OPTIONS

A: PC and field configurable

B: Field configurable

[2] OPTIONS**STANDARDS & APPROVALS**

blank: CE marking

/UL: UL approval, CE marking

RELATED PRODUCTS

- PC configurator software (model: M3CON)

Downloadable at M-System's web site.

A dedicated cable is required to connect the module to the PC. Please refer to the internet software download site or the users manual for the PC configurator for applicable cable types.

GENERAL SPECIFICATIONS**Construction:** Small-sized front terminal structure**Connection:** Euro type connector terminal**Housing material:** Flame-resistant resin (gray)**Isolation:** Input to output to power**Overrange output:** -15 to +115 %**Zero adjustment:** -15 to +15 % (front)**Span adjustment:** 85 to 115 % (front)**Burnout:** Upscale (default), downscale or no burnout selectable**Cold junction compensation:** CJC sensor attached to the input terminals**Status indicator LED:** Tri-color (green/amber/red) LED;

Flashing patterns indicate operation status of the transmitter.

Configuration: Via PC configurator and DIP SW**Programmable features include:**

- I/O type and range
- Zero and span adjustments
- Burnout action
- User's T/C table setting
(max. 300 points, input emf specified within -100 - +1000 mV)
- Others

(Refer to the instruction manual)

'One-Step Cal' calibration: With I/O type and the full-scale range configured via the internal DIP switches, precise 0 % and 100 % ranges are calibrated via the front control

buttons with a help of LED.

INPUT SPECIFICATIONS

- **Thermocouple:** See table 1
- Input resistance:** $\geq 1 \text{ M}\Omega$
- Burnout sensing:** $130 \text{ nA} \pm 10 \%$
- Temperature range:** See Table 1.

OUTPUT SPECIFICATIONS

■ DC CURRENT

- Maximum range:** 0 - 20 mA DC
- Minimum span:** 1 mA
- Conformance range:** 0 - 24 mA DC (Negative overrange current below 0 mA is not available.)
- Offset:** Lower range can be any specific value within the output range provided that the minimum span is maintained.
- Load resistance:** Output drive 12 V maximum

■ DC VOLTAGE

- Narrow Spans (mV)**
 - Maximum range:** -2.5 - +2.5 V DC
 - Minimum span:** 250 mV
 - Conformance range:** -3 - +3 V DC
- Wide Spans (V)**
 - Maximum range:** -10 - +10 V DC
 - Minimum span:** 1 V
 - Conformance range:** -11.5 - +11.5 V DC
- Offset:** Lower range can be any specific value within the output range provided that the minimum span is maintained.
- Load resistance:** Output drive 1 mA maximum

INSTALLATION

- Power Consumption**
 - **DC power input:** Approx. 3 W
- Operating temperature:** -25 to +65°C (-13 to +149°F)
Max. 55°C (131°F) for UL approval
- Operating humidity:** 0 to 95 %RH (non-condensing)
- Mounting:** DIN rail
- Weight:** 100 g (3.53 oz)

PERFORMANCE

- Accuracy:** See Table 1.
- Cold junction compensation error:**
 - $\pm 0.5^\circ\text{C}$ at $25 \pm 10^\circ\text{C}$
 - $\pm 0.9^\circ\text{F}$ at $77 \pm 18^\circ\text{F}$
- Temp. coefficient:** $\pm 0.015 \%/^\circ\text{C}$ ($\pm 0.008 \%/^\circ\text{F}$) of max. span at -5 to +55°C [23 to 131°F]
- Response time:** $\leq 0.9 \text{ sec.}$ (0 - 90 %)
- Burnout response:** $\leq 10 \text{ sec.}$

- Line voltage effect:** $\pm 0.1 \%$ over voltage range
- Insulation resistance:** $\geq 100 \text{ M}\Omega$ with 500 V DC
- Dielectric strength:** 1500 V AC @ 1 minute
(input to output or power to ground)
500 V AC @ 1 minute (output to power)

CALCULATION EXAMPLES OF OVERALL ACCURACY

[Example 1]

- Input: K thermocouple, 0 - 1000°C, Output: 4 - 20 mA DC
- 1) Absolute value accuracy (Table 1): 0.25°C
 - 2) CJC error (0.5°C) added: 0.75°C
 - 3) $0.75^\circ\text{C} / 1000^\circ\text{C} \times 100 = 0.075 \%$
 - 4) $0.075 \% < 0.1 \%$ of span. $\Rightarrow 0.1 \%$ is selected.
 - 5) Output span 16 mA (= 20 mA - 4 mA)
Max. span 20 mA
Output span $\geq 1/10$ of max. span \Rightarrow No need of adding 0.2 %.
 - 6) Overall accuracy equals $\pm 0.1 \%$ of span

[Example 2]

- Input: K thermocouple, 50 - 150°C, Output: 2.0 - 2.5 V DC
- 1) Absolute value accuracy (Table 1): 0.25°C
 - 2) CJC error (0.5°C) added: 0.75°C
 - 3) $0.75^\circ\text{C} / (150 - 50)^\circ\text{C} \times 100 = 0.75 \%$
 - 4) $0.75 \% > 0.1 \%$ of span. $\Rightarrow 0.75 \%$ is selected.
 - 5) Output span 0.5 V (= 2.5 V - 2.0 V)
Max. span 5 V
Output span $\leq 1/10$ of max. span \Rightarrow Add 0.2 %.
 - 6) Overall accuracy equals $\pm 0.95 \%$ of span ($0.75 + 0.2$)

STANDARDS & APPROVALS

CE conformity:

- EMC Directive (2004/108/EC)
- EMI EN 61000-6-4: 2007
- EMS EN 61000-6-2: 2005

Approval:

- UL/C-UL general safety requirements
(UL 61010-1, CAN/CSA-C22.2 No.1010-1)

EXTERNAL VIEW

FRONT VIEW

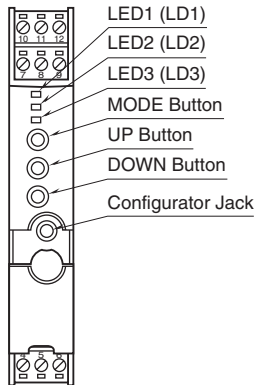

SIDE VIEW

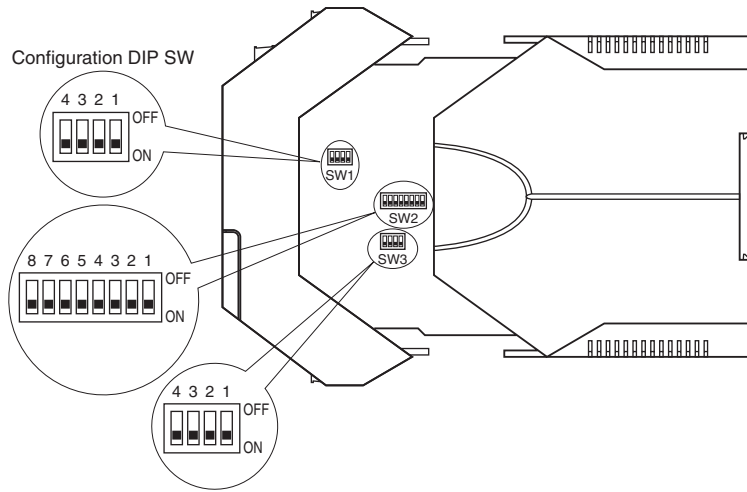

INPUT TYPE, RANGE & ACCURACY

Table 1

Thermocouple	°C				°F			
	MIN. SPAN	MAXIMUM RANGE	CONFORMANCE RANGE	ACCURACY *1	MIN. SPAN	MAXIMUM RANGE	CONFORMANCE RANGE	ACCURACY *1
(PR)	20	0 to 1760	0 to 1760	±1.00	36	32 to 3200	32 to 3200	±1.80
K (CA)	20	-270 to +1370	-150 to +1370	±0.25	36	-454 to +2498	-238 to +2498	±0.45
E (CRC)	20	-270 to +1000	-170 to +1000	±0.20	36	-454 to +1832	-274 to +1832	±0.36
J (IC)	20	-210 to +1200	-180 to +1200	±0.25	36	-346 to +2192	-292 to +2192	±0.45
T (CC)	20	-270 to +400	-170 to +400	±0.25	36	-454 to +752	-274 to +752	±0.45
B (RH)	20	100 to 1820	400 to 1760	±0.75	36	212 to 3308	752 to 3200	±1.35
R	20	-50 to +1760	200 to 1760	±0.50	36	-58 to +3200	392 to 3200	±0.90
S	20	-50 to +1760	0 to 1760	±0.50	36	-58 to +3200	32 to 3200	±0.90
C (WRe 5-26)	20	0 to 2315	0 to 2315	±0.80	36	32 to 4199	32 to 4199	±1.44
N	20	-270 to +1300	-130 to +1300	±0.30	36	-454 to +2372	-202 to +2372	±0.54
U	20	-200 to +600	-200 to +600	±0.20	36	-328 to +1112	-328 to +1112	±0.36
L	20	-200 to +900	-200 to +900	±0.25	36	-328 to +1652	-328 to +1652	±0.45
P (Platinel II)	20	0 to 1395	0 to 1395	±0.25	36	32 to 2543	32 to 2543	±0.45

*1. [Accuracy + Cold Junction Compensation Error 0.5°C (0.9°F)] or ±0.1% of span, whichever is greater.
If the selected output span equals to or narrower than the one-tenth of the maximum span, add 0.2%

EXTERNAL DIMENSIONS & TERMINAL ASSIGNMENTS unit: mm (inch)

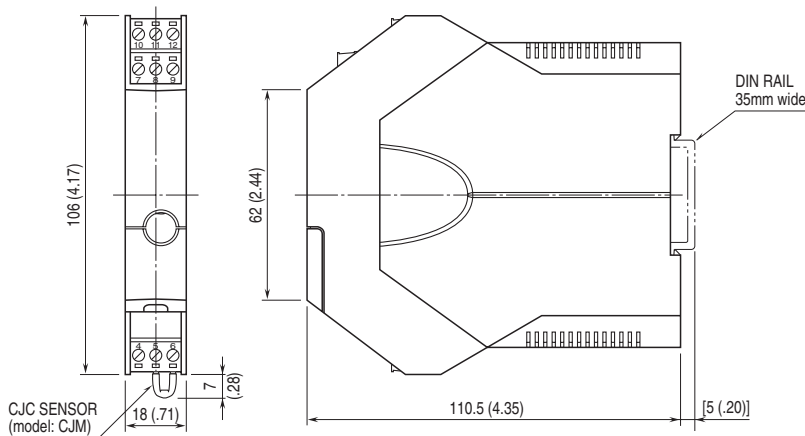

• When mounting, no extra space is needed between units.

SCHEMATIC CIRCUITRY & CONNECTION DIAGRAM

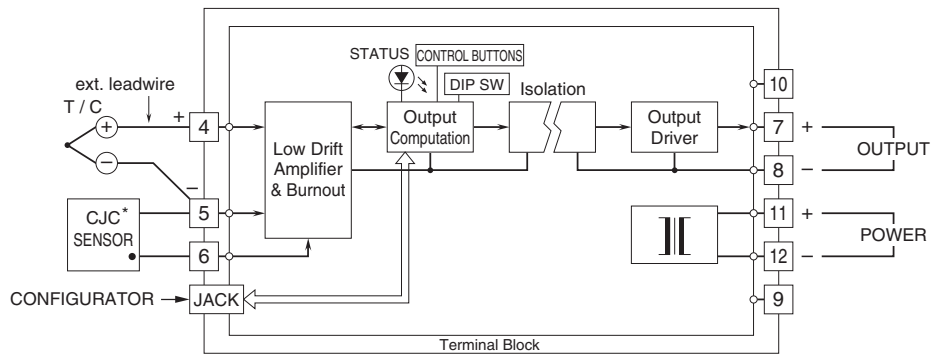

*The CJC Sensor is secured to the terminal 6.
Loosen only the terminal 4 – 5 and connect the T/C extension wires.



Specifications are subject to change without notice.