

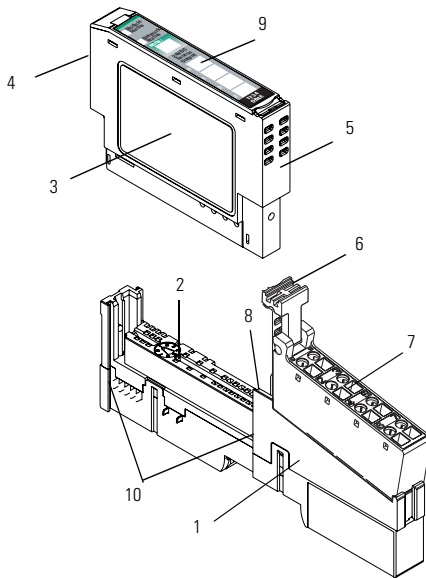

Installation Instructions

POINT I/O Protected Output Module

(Cat. No. 1734-OB2E, -OB4E and -OB8E Series C)



	Description		Description
1	Mounting Base ¹	6	RTB Removal Handle
2	Mechanical Keying (orange)	7	Removable Terminal Block (RTB) ¹
3	Module Wiring Diagram	8	DIN Rail Locking Screw (orange)
4	Module Locking Mechanism	9	Slide-in Writable Label
5	Insertable I/O Module	10	Interlocking Side Pieces

¹ Wiring Base Assembly consists of item 1) mounting base, 1734-MB and item 7) removable terminal block, 1734-RTB or -RTBS.

This Series C product can be used with DeviceNet and PROFIBUS adapters. It can be used with ControlNet and Ethernet adapters using RSLogix 5000, version 11 (or higher) software.

Important User Information

Solid state equipment has operational characteristics differing from those of electromechanical equipment. *Safety Guidelines for the Application, Installation and Maintenance of Solid State Controls* (Publication SGI-1.1 available from your local Rockwell Automation sales office or online at <http://www.literature.rockwellautomation.com>) describes some important differences between solid state equipment and hard-wired electromechanical devices. Because of this difference, and also because of the wide variety of uses for solid state equipment, all persons responsible for applying this equipment must satisfy themselves that each intended application of this equipment is acceptable.



In no event will Rockwell Automation, Inc. be responsible or liable for indirect or consequential damages resulting from the use or application of this equipment.

The examples and diagrams in this manual are included solely for illustrative purposes. Because of the many variables and requirements associated with any particular installation, Rockwell Automation, Inc. cannot assume responsibility or liability for actual use based on the examples and diagrams.

No patent liability is assumed by Rockwell Automation, Inc. with respect to use of information, circuits, equipment, or software described in this manual.

Reproduction of the contents of this manual, in whole or in part, without written permission of Rockwell Automation, Inc. is prohibited.

Throughout this manual we use notes to make you aware of safety considerations.

<p>WARNING</p> 	<p>Identifies information about practices or circumstances that can cause an explosion in a hazardous environment, which may lead to personal injury or death, property damage, or economic loss.</p>
<p>ATTENTION</p> 	<p>Identifies information about practices or circumstances that can lead to personal injury or death, property damage, or economic loss. Attentions help you:</p> <ul style="list-style-type: none"> • identify a hazard • avoid a hazard • recognize the consequence

Important User Information**IMPORTANT**

Identifies information that is critical for successful application and understanding of the product.

SHOCK HAZARD

Labels may be located on or inside the equipment (e.g., drive or motor) to alert people that dangerous voltage may be present.

BURN HAZARD

Labels may be located on or inside the equipment (e.g., drive or motor) to alert people that surfaces may be dangerous temperatures.

ATTENTION



Environment and Enclosure

This equipment is intended for use in a Pollution Degree 2 industrial environment, in overvoltage Category II applications (as defined in IEC publication 60664-1), at altitudes up to 2000 meters without derating.

This equipment is considered Group 1, Class A industrial equipment according to IEC/CISPR Publication 11. Without appropriate precautions, there may be potential difficulties ensuring electromagnetic compatibility in other environments due to conducted as well as radiated disturbance.

This equipment is supplied as "open type" equipment. It must be mounted within an enclosure that is suitably designed for those specific environmental conditions that will be present and appropriately designed to prevent personal injury resulting from accessibility to live parts. The interior of the enclosure must be accessible only by the use of a tool. Subsequent sections of this publication may contain additional information regarding specific enclosure type ratings that are required to comply with certain product safety certifications.

See NEMA Standards publication 250 and IEC publication 60529, as applicable, for explanations of the degrees of protection provided by different types of enclosure. Also, see the appropriate sections in this publication, as well as the Allen-Bradley publication 1770-4.1 ("Industrial Automation Wiring and Grounding Guidelines"), for additional installation requirements pertaining to this equipment.

ATTENTION



POINT I/O is grounded through the DIN rail to chassis ground. Use zinc plated, yellow chromated steel DIN rail to assure proper grounding. Using other DIN rail materials (e.g. aluminum, plastic, etc.) which can corrode, oxidize or are poor conductors can result in improper or intermittent platform grounding.

WARNING**EXPLOSION HAZARD**

- Do not disconnect equipment unless power has been removed or the area is known to be nonhazardous.
 - Do not disconnect connections to this equipment unless power has been removed or the area is known to be nonhazardous. Secure any external connections that mate to this equipment by using screws, sliding latches, threaded connectors, or other means provided with this product.
 - Substitution of components may impair suitability for Class I, Division 2.
 - If this product contains batteries, they must only be changed in an area known to be nonhazardous.
-

ATTENTION**Preventing Electrostatic Discharge**

This equipment is sensitive to electrostatic discharge, which can cause internal damage and affect normal operation. Follow these guidelines when you handle this equipment:

- Touch a grounded object to discharge potential static.
 - Wear an approved grounding wriststrap.
 - Do not touch connectors or pins on component boards.
 - Do not touch circuit components inside the equipment.
 - If available, use a static-safe workstation.
 - When not in use, store the equipment in appropriate static-safe packaging.
-

Installing the Mounting Base

To install the mounting base on the DIN rail, proceed as follows.

1. Position the mounting base vertically above the installed units (adapter, power supply or existing module).
2. Slide the mounting base down allowing the interlocking side pieces to engage the adjacent module or adapter.
3. Press firmly to seat the mounting base on the DIN rail. The mounting base will snap into place.
4. To remove the mounting base from the DIN rail, remove the module, and use a small bladed screwdriver to rotate the base locking screw to a vertical position. This releases the locking mechanism. Then lift straight up to remove.

Installing the I/O Module

The module can be installed before, or after base installation. Make sure that the mounting base is correctly keyed before installing the module into the mounting base. In addition, make sure the mounting base locking screw is positioned horizontal referenced to the base.

WARNING



When you insert or remove the module while backplane power is on, an electrical arc can occur. This could cause an explosion in hazardous location installations. Be sure that power is removed or the area is nonhazardous before proceeding.

1. Using a bladed screwdriver, rotate the keyswitch (2) on the mounting base clockwise until the number required for the type of module being installed aligns with the notch in the base.
2. Make certain the DIN rail locking screw is in the horizontal position. (You cannot insert the module if the locking mechanism is unlocked.)
3. Insert the module straight down into the mounting base and press to secure. The module will lock into place.

Installing the Removable Terminal Block (RTB)

A removable terminal block is supplied with your wiring base assembly. To remove, pull up on the RTB handle. This allows the mounting base to be removed and replaced as necessary without removing any of the wiring. To reinsert the removable terminal block, proceed as follows.

1. Insert the end opposite the handle into the base unit. This end has a curved section that engages with the wiring base.
2. Rotate the terminal block into the wiring base until it locks itself in place.
3. If an I/O module is installed, snap the RTB handle into place on the module.

WARNING



When you connect or disconnect the Removable Terminal Block (RTB) with field side power applied, an electrical arc can occur. This could cause an explosion in hazardous location installations. Be sure that power is removed or the area is nonhazardous before proceeding.

Removing a Mounting Base

To remove a mounting base, you must remove any installed module, and the module installed in the base to the right. Remove the removable terminal block (if wired).

1. Unlatch the RTB handle on the I/O module.
2. Pull on the RTB handle to remove the removable terminal block.

WARNING



When you connect or disconnect the Removable Terminal Block (RTB) with field side power applied, an electrical arc can occur. This could cause an explosion in hazardous location installations. Be sure that power is removed or the area is nonhazardous before proceeding.

3. Press on the module lock on the top of the module.
4. Pull on the I/O module to remove from the base.

WARNING



If you insert or remove the module while backplane power is on, an electrical arc can occur. This could cause an explosion in hazardous location installations. Be sure that power is removed or the area is nonhazardous before proceeding.

5. Repeat steps 1, 2, 3 and 4 for the module to the right.
6. Use a small bladed screwdriver to rotate the orange base locking screw to a vertical position. This releases the locking mechanism.
7. Then lift straight up to remove.

Communicating with Your Module

I/O messages are sent to (consumed) and received from (produced) the POINT I/O modules. These messages are mapped into the processor's memory. This POINT I/O output module produces 1 byte of input data (scanner Rx) (status). It consumes 1 byte of I/O data (scanner Tx).

Default Data Map for the 1734-OB2E Output Module

Message size: 1 Byte

	7	6	5	4	3	2	1	0	
Produces (scanner Rx)	Not used						Ch1	Ch0	Channel status
Where: 0 = no error, 1 = error									

Message size: 1 Byte

	7	6	5	4	3	2	1	0	
Consumes (scanner Tx)	Not used						Ch1	Ch0	Channel state
Where: 0 = Off, 1 = On									

Default Data Map for the 1734-OB4E Output Module

Message size: 1 Byte

	7	6	5	4	3	2	1	0	
Produces (scanner Rx)	Not used				Ch3	Ch2	Ch1	Ch0	Channel status
Where: 0 = no error, 1 = error									

Message size: 1 Byte

	7	6	5	4	3	2	1	0	
Consumes (scanner Tx)	Not used				Ch3	Ch2	Ch1	Ch0	Channel state
Where: 0 = Off, 1 = On									

Default Data Map for the 1734-OB8E Output Module

Message size: 1 Byte

	7	6	5	4	3	2	1	0	
Produces (scanner Rx)	Ch7	Ch6	Ch5	Ch4	Ch3	Ch2	Ch1	Ch0	Channel status
Where: 0 = no error, 1 = error									

Message size: 1 Byte

	7	6	5	4	3	2	1	0	
Consumes (scanner Tx)	Ch7	Ch6	Ch5	Ch4	Ch3	Ch2	Ch1	Ch0	Channel state
Where: 0 = Off, 1 = On									

Wiring the Protected Output Modules

WARNING



If you connect or disconnect wiring while field side power is on, an electrical arc can occur. This could cause an explosion in hazardous location installations.

Be sure that power is removed or the area is nonhazardous before proceeding.

1734-OB2E

1734-OB4E

1734-OB8E

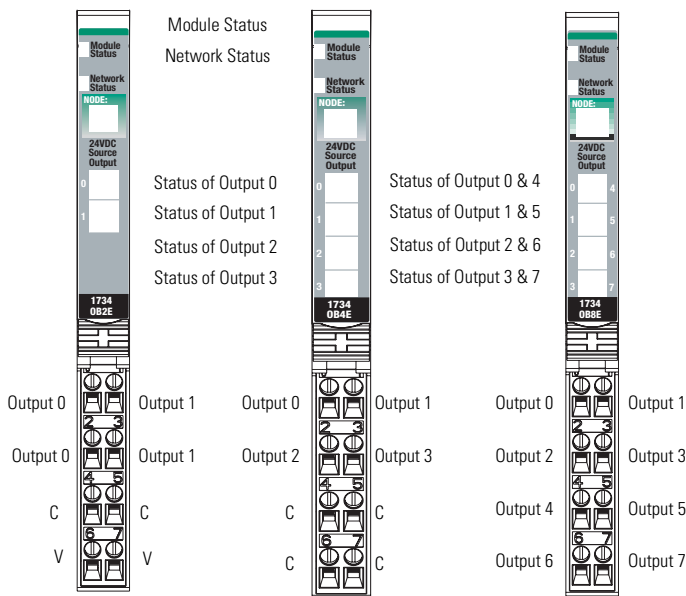

C = Common
V = Supply

42016

dc Output Module Cat. No. 1734-OB2E

WARNING



If you connect or disconnect wiring while field side power is on, an electrical arc can occur. This could cause an explosion in hazardous location installations.

Be sure that power is removed or the area is nonhazardous before proceeding.

1734-OB2E

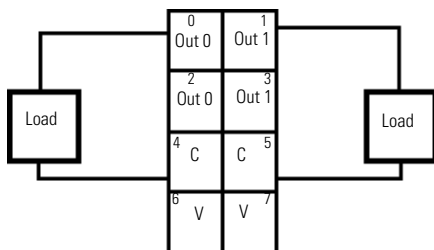

V = 12/24V dc, C = Common
 Field power is supplied from internal power bus

42014

	Output Terminal	Common Terminal	Power
Channel 0	0, 2	4	6
Channel 1	1, 3	5	7

Module power is supplied from the internal power bus.

dc Output Module Cat. No. 1734-OB4E**WARNING**

If you connect or disconnect wiring while field side power is on, an electrical arc can occur. This could cause an explosion in hazardous location installations.

Be sure that power is removed or the area is nonhazardous before proceeding.

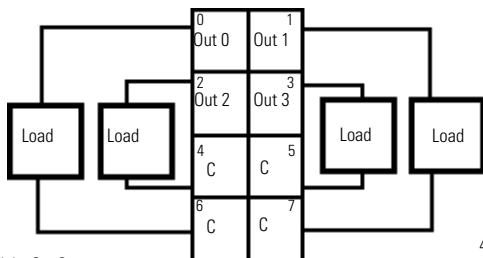
1734-OB4E

V = 12/24V dc, C = Common
Field power is supplied from internal power bus

	Output Terminal	Common Terminal	Power
Channel 0	0	6	
Channel 1	1	7	
Channel 2	2	4	
Channel 3	3	5	

Module power is supplied from internal power bus.

dc Output Module Cat. No. 1734-OB8E

WARNING



If you connect or disconnect wiring while field side power is on, an electrical arc can occur. This could cause an explosion in hazardous location installations.

Be sure that power is removed or the area is nonhazardous before proceeding.

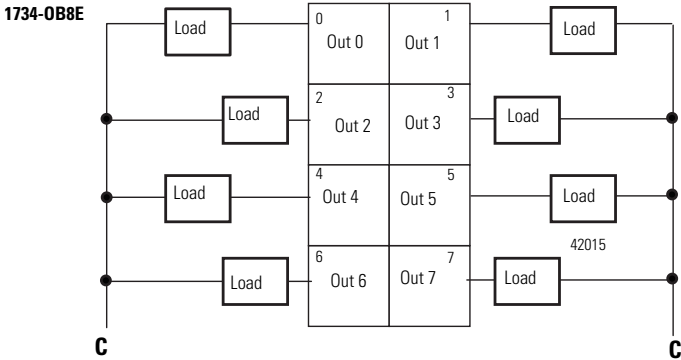

Common must be daisychained from a 1734 adapter, 1734-FPD, 1734-EP24DC, or from a user-supplied auxiliary terminal block. The 24V dc power to the module is supplied by the internal power bus and comes from the same 1734 adapter, 1734-FPD, or 1734-EP24DC as common.

Channel Number	Output Terminal	Common Terminal	Power
Channel 0	0	Common is daisychained from either a 1734 adapter, 1734-FPD, 1734-EP24DC or from a user-supplied external terminal block.	The 24V dc power for the module is supplied by the internal power bus and originates from the same adapter, 1734-FPD or 1734-EP24DC as common.
Channel 1	1		
Channel 2	2		
Channel 3	3		
Channel 4	4		
Channel 5	5		
Channel 6	6		
Channel 7	7		

Module power is supplied from the internal power bus.

Example of Wiring for the 1734-OB8E Output Module

WARNING



If you connect or disconnect wiring while field side power is on, an electrical arc can occur. This could cause an explosion in hazardous location installations.

Be sure that power is removed or the area is nonhazardous before proceeding.

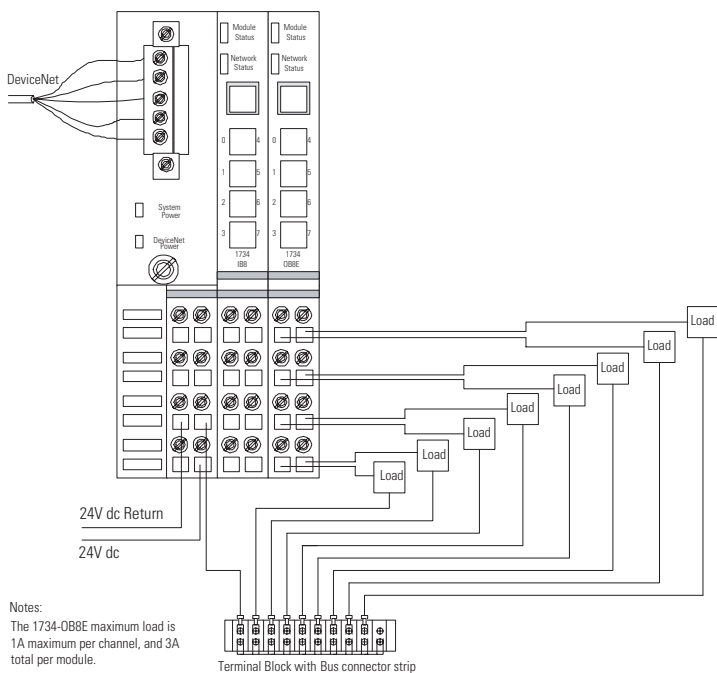

Troubleshooting with the Indicators

1734-OB2E

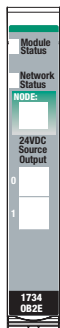

Module Status
 Network Status
 NODE
 24VDC Source Output
 0 Status of Output 0
 1 Status of Output 1
 2 Status of Output 2
 3 Status of Output 3

1734-OB4E

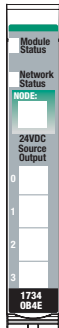

Module Status
 Network Status
 NODE
 24VDC Source Output
 0 Status of Output 0 & 4
 1 Status of Output 1 & 5
 2 Status of Output 2 & 6
 3 Status of Output 3 & 7

1734-OB8E

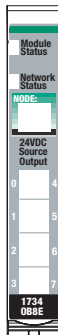



Indication	Probable Cause
Module Status	
Off	No power applied to device
Green	Device operating normally
Flashing Green	Device needs commissioning due to configuration missing, incomplete or incorrect.
Flashing Red	Recoverable fault.
Red	Unrecoverable fault may require device replacement
Flashing Red/Green	Device is in self-test

Indication	Probable Cause
Network Status	
Off	Device is not on-line - Device has not completed dup_MAC_id test. - Device not powered - check module status indicator
Flashing Green	Device is on-line but has no connections in the established state.
Green	Device on-line and has connections in the established state.
Flashing Red	One or more I/O connections in timed-out state
Red	Critical link failure - failed communication device. Device detected error that prevents it communicating on the network.
Flashing Red/Green	Communication faulted device - the device has detected a network access error and is in communication faulted state. Device has received and accepted an Identify Communication Faulted Request - long protocol message.

Indication	Probable Cause
I/O Status	
Off	All outputs inactive
Yellow	One or more output is active and under control
Flashing Red	Open circuit detected. No load. (Off-State only)
Red	Short circuit detected.

Safety Approvals

North American Hazardous Location Approval

The following information applies when operating this equipment in hazardous locations:	Informations sur l'utilisation de cet équipement en environnements dangereux:
<p>Products marked "CL I, DIV 2, GP A, B, C, D" are suitable for use in Class I Division 2 Groups A, B, C, D, Hazardous Locations and nonhazardous locations only. Each product is supplied with markings on the rating nameplate indicating the hazardous location temperature code. When combining products within a system, the most adverse temperature code (lowest "T" number) may be used to help determine the overall temperature code of the system. Combinations of equipment in your system are subject to investigation by the local Authority Having Jurisdiction at the time of installation.</p>	<p>Les produits marqués "CL I, DIV 2, GP A, B, C, D" ne conviennent qu'à une utilisation en environnements de Classe I Division 2 Groupes A, B, C, D dangereux et non dangereux. Chaque produit est livré avec des marquages sur sa plaque d'identification qui indiquent le code de température pour les environnements dangereux. Lorsque plusieurs produits sont combinés dans un système, le code de température le plus défavorable (code de température le plus faible) peut être utilisé pour déterminer le code de température global du système. Les combinaisons d'équipements dans le système sont sujettes à inspection par les autorités locales qualifiées au moment de l'installation.</p>
<div style="display: flex; align-items: center;"> <div style="background-color: black; color: white; padding: 5px; margin-right: 10px;">WARNING</div> <div style="text-align: center;">  </div> </div> <p>EXPLOSION HAZARD -</p> <ul style="list-style-type: none"> Do not disconnect equipment unless power has been removed or the area is known to be nonhazardous. Do not disconnect connections to this equipment unless power has been removed or the area is known to be nonhazardous. Secure any external connections that mate to this equipment by using screws, sliding latches, threaded connectors, or other means provided with this product. Substitution of components may impair suitability for Class I, Division 2. If this product contains batteries, they must only be changed in an area known to be nonhazardous. 	<div style="display: flex; align-items: center;"> <div style="background-color: black; color: white; padding: 5px; margin-right: 10px;">AVERTISSEMENT</div> <div style="text-align: center;">  </div> </div> <p>RISQUE D'EXPLOSION –</p> <ul style="list-style-type: none"> Couper le courant ou s'assurer que l'environnement est classé non dangereux avant de débrancher l'équipement. Couper le courant ou s'assurer que l'environnement est classé non dangereux avant de débrancher les connecteurs. Fixer tous les connecteurs externes reliés à cet équipement à l'aide de vis, loquets coulissants, connecteurs filetés ou autres moyens fournis avec ce produit. La substitution de composants peut rendre cet équipement inadapte à une utilisation en environnement de Classe 1, Division 2. S'assurer que l'environnement est classé non dangereux avant de changer les piles.

European Hazardous Location Approval

European Zone 2 Certification (The following applies when the product bears the EEx Marking)

This equipment is intended for use in potentially explosive atmospheres as defined by European Union Directive 94/9/EC.

DEMKO certifies that this equipment has been found to comply with the Essential Health and Safety Requirements relating to the design and construction of Category 3 equipment intended for use in potentially explosive atmospheres, given in Annex II to this Directive. The examination and test results are recorded in EC-type-examination certificate DEMKO 04 ATEX 0330347 X.

Compliance with the Essential Health and Safety Requirements has been assured by compliance with EN 50021.

IMPORTANT

Observe the following additional Zone 2 certification requirements.

- This equipment is not resistant to sunlight or other sources of UV radiation.
 - The secondary of a current transformer shall not be open-circuited when applied in Class I, Zone 2 environments.
 - Equipment of lesser Enclosure Type Rating must be installed in an enclosure providing at least IP54 protection when applied in Class I, Zone 2 environments.
 - This equipment shall be used within its specified ratings defined by Allen-Bradley.
 - Provision shall be made to prevent the rated voltage from being exceeded by transient disturbances of more than 40% when applied in Class I, Zone 2 environments
-

Specifications - 1734-OB2E, -OB4E and -OB8E Protected Output Modules**Output Specifications**

Number of Outputs	1734-OB2E - 2 (1 group of 2) nonisolated, sourcing 1734-OB4E - 4 (1 group of 4) nonisolated, sourcing 1734-OB8E - 8 (1 group of 8) nonisolated, sourcing
ON-State Voltage Range	10V dc minimum 24V dc nominal 28.8V dc maximum
ON-State Voltage Drop	0.2V dc maximum
ON-State Current	1.0 mA minimum per channel
OFF-State Voltage	28.8V dc maximum
OFF-State Leakage	0.5 mA maximum
Output Signal Delay ¹ OFF to ON ON to OFF	0.1 ms maximum 0.1 ms maximum
Output Current Rating	1734-OB2E - 1.0 A per output, 2.0 A maximum per module 1734-OB4E and 1734-OB8E - 1.0 A per output, not to exceed 3.0 A maximum per module
Surge Current	2 A for 10 ms, repeatable every 3 seconds
Indicators (field side indication, logic driven)	1734-OB2E 2 yellow output status; 2 red output fault 2 green/red module/network status 1734-OB4E 4 yellow output status; 4 red output fault 2 green/red module/network status 1734-OB8E 8 yellow output status; 8 red output fault 2 green/red module/network status
Keyswitch Position	1

General Specifications

Module Location	1734-TB or -TBS wiring base assembly
Pointbus Current	75 mA maximum @ 5V dc
Power Dissipation	1734-OB2E - 0.8 W maximum @ 28.8V dc 1734-OB4E - 1.2 W maximum @ 28.8V dc 1734-OB8E - 2.0 W maximum @ 28.8V dc
Thermal Dissipation	1734-OB2E - 2.7 BTU/hr maximum @ 28.8V dc 1734-OB4E - 4.1 BTU/hr maximum @ 28.8V dc 1734-OB8E - 6.8 BTU/hr maximum @ 28.8V dc

Isolation Voltage	50V continuous Tested to withstand 2500V dc for 60 s
External dc Power Supply Voltage Voltage Range Supply Current	24V dc nominal 10 to 28.8V dc 1734-OB2E - 8 mA 1734-OB4E - 16 mA 1734-OB8E - 32 mA
Dimensions Inches (Millimeters)	2.21H x 0.47W x 2.97L (56.0H x 12.0W x 75.5L)
Environmental Conditions	
Operational Temperature	IEC 60068-2-1 (Test Ad, Operating Cold), IEC 60068-2-2 (Test Bd, Operating Dry Heat), IEC 60068-2-14 (Test Nb, Operating Thermal Shock): -20 to 55 °C (-4 to 131 °F)
Storage Temperature	IEC 60068-2-1 (Test Ab, Unpackaged Nonoperating Cold), IEC 60068-2-2 (Test Bb, Unpackaged Nonoperating Dry Heat), IEC 60068-2-14 (Test Na, Unpackaged Nonoperating Thermal Shock): -40 to 85 °C (-40 to 185 °F)
Relative Humidity	IEC 60068-2-30 (Test Db, Unpackaged Nonoperating, Damp Heat): 5 to 95% noncondensing
Shock Operating Non-operating	IEC 60068-2-27 (Test Ea, Unpackaged Shock) 30g 50g
Vibration	IEC 60068-2-6, (Test Fc, Operating) 5g @ 10-500 Hz
ESD Immunity	IEC 61000-4-2: 6 kV contact discharges 8 kV air discharges
Radiated RF Immunity	IEC 61000-4-3: 10 V/m with 200 Hz 50% Pulse 100%AM at 1890 Mhz 10 V/m with 200 Hz 50% Pulse 100%AM at 900 Mhz 10 V/m with 1kHz sine-wave 80%AM from 30 MHz to 2000 MHz
EFT/B Immunity	IEC 61000-4-4: ±4 kV at 2.5 kHz on signal ports
Surge Transient Immunity	IEC 61000-4-5: ±1 kV line-line(DM) and ±2 kV line-earth(CM) on signal ports

Certifications (when product is marked)³

- C-UL-US** - UL Listed Industrial Control Equipment, certified for US and Canada
- C-UL-US** - UL Listed for Class I, Division 2, Groups A, B, C and D Hazardous locations, certified for US and Canada
- EEx** European Union 94/9/EEC ATEX Directive, compliant with:
EN 50021; Potentially Explosive Atmospheres, Protection "n" (Zone 2)
- CE** European Union 89/336/EEC EMC Directive, compliant with:
EN 61000-6-4; Industrial Emissions
EN 50082-2; Industrial Immunity
EN 61326; Meas./Control/Lab., Industrial Requirements
EN 61000-6-2; Industrial Immunity
- C-Tick** Australian Radiocommunications Act compliant with AS/NZS CISPR 11, Industrial Emissions

- 1 Off/on delay is time from a valid output "on" signal to output energization. On/off delay is time from a valid output "off" signal to output deenergization.
- 2 Use this conductor category information for planning conductor routing as described in publication 1770-4.1, "Industrial Automation Wiring and Grounding Guidelines."
- 3 See the Product Certification link at www.ab.com for Declarations of Conformity, Certificates, and other certification details.

www.rockwellautomation.com

Power, Control and Information Solutions Headquarters

Americas: Rockwell Automation, 1201 South Second Street, Milwaukee, WI 53204-2496 USA, Tel: (1) 414.382.2000, Fax: (1) 414.382.4444
Europe/Middle East/Africa: Rockwell Automation, Vorstlaan/Boulevard du Souverain 36, 1170 Brussels, Belgium, Tel: (32) 2 663 0600, Fax: (32) 2 663 0640
Asia Pacific: Rockwell Automation, Level 14, Core F, Cyberport 3, 100 Cyberport Road, Hong Kong, Tel: (852) 2887 4788, Fax: (852) 2508 1846

Publication 1734-IN056E-EN-E - June 2005

Supersedes Publication 1734-IN056D-EN-P - April 2004

PN 957899-51

© 2005 Rockwell International Corporation. Printed in USA