

Space-saving Signal Conditioners M3-UNIT Series

RS-422 line driver pulse

FREQUENCY TRANSMITTER

(field- and PC-configurable)

Functions & Features

- Converts the output from a pulse-type transducer into a standard process signal
- Sensor excitation
- Easy 'One-Step Cal' calibration using the front three control buttons without needing a PC; PC software is also usable.
- Both input and output type and range are configurable
- Front control button function can be locked
- CE marking
- UL approval

Typical Applications

- Positive displacement flowmeters, turbine flowmeters and vortex flowmeters
- Measuring rotation speed of a machine generating dry contact signals

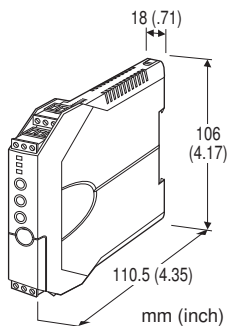

MODEL: M3LPA2-[1]/[2][3]

ORDERING INFORMATION

- Code number: M3LPA2-[1]/[2][3]
- Specify a code from below for each [1] through [3]. (e.g. M3LPA2-R4/A/UL)
- Factory default setting:
 - Input type: Open collector
 - Frequency range: 0 - 100 kHz
 - Sensor excitation: 12 V DC / 20 mA
 - Output range: 4 - 20 mA
 - Threshold: 2 V

INPUT - Field-selectable

- Open collector
- Mechanical contact
- Voltage pulse
- Two-wire current pulse

EXCITATION SELECTION

- 4 V DC / 20 mA
- 8 V DC / 20 mA
- 12 V DC / 20 mA

OUTPUT - Field-selectable

Current

0 - 20 mA DC

Voltage

- 2.5 - +2.5 V DC
- 10 - +10 V DC

[1] POWER INPUT

AC Power

M2: 100 - 240 V AC (Operational voltage range 85 - 264 V, 47 - 66 Hz)

(*'/UL' is not selectable for 'Standards & Approvals' code.)

DC Power

R4: 10 - 32 V DC

(Operational voltage range 9 - 36 V, ripple 10 %p-p max.)

[2] CONFIGURATION OPTIONS

- A: PC and field configurable
- B: Field configurable

[3] OPTIONS

STANDARDS & APPROVALS

- blank: CE marking
- /UL: UL approval, CE marking

RELATED PRODUCTS

- PC configurator software (model: M3CFG)
- Downloadable at M-System's web site.
- A dedicated cable is required to connect the module to the PC. Please refer to the internet software download site or the users manual for the PC configurator for applicable cable types.

GENERAL SPECIFICATIONS

Construction: Small-sized front terminal structure

Connection: Euro type connector terminal

Housing material: Flame-resistant resin (gray)

Isolation: Input to output to power

Overrange output: -15 to +115 %

Zero adjustment: -15 to +15 % (front)

Span adjustment: 85 to 115 % (front)

Status indicator LED: Tri-color (green/amber/red) LED;

Flashing patterns indicate operation status of the transmitter.

PC configurator: Programmable features include:

- I/O type and range, threshold
- Zero and span adjustments
- User's linearization table setting (max. 101 points, specified within -15 to +115 % for both input and output)
- Sampling time (0.05 – 100 sec.) (Refer to the instruction manual)

'One-Step Cal' calibration: With I/O type and the full-scale range configured via the internal DIP switches, precise 0 % and 100 % ranges are calibrated via the front control buttons with a help of LED.

INPUT SPECIFICATIONS

Measurable frequencies: Minimum span 10 % of the frequency range selected in Table 2. (5 % for 0 – 200 kHz range)

See each input type for the maximum span.

Pulse width time requirement: Min. 5 μ sec., max. 10 sec.

■ OPEN COLLECTOR

Maximum frequency: 0 – 200 kHz

- Excitation: 4 V

Sensing voltage/current: Approx. 3V / 0.7 mA

Input requirements:

$\leq 200 \Omega / 0.2 \text{ V}$ for ON; $\geq 2 \text{ k}\Omega / 1 \text{ V}$ for OFF

Detecting level: 0.6 V

- Excitation: 8 V

Sensing voltage/current: Approx. 6V / 1.5 mA

Input requirements:

$\leq 600 \Omega / 1 \text{ V}$ for ON; $\geq 4 \text{ k}\Omega / 3 \text{ V}$ for OFF

Detecting level: 2 V

- Excitation: 12 V

Sensing voltage/current: Approx. 9V / 2.3 mA

Input requirements:

$\leq 400 \Omega / 1 \text{ V}$ for ON; $\geq 2 \text{ k}\Omega / 3 \text{ V}$ for OFF

Detecting level: 2 V

■ MECHANICAL CONTACT

Maximum frequency: 0 – 10 Hz

- Excitation: 4 V

Sensing voltage/current: Approx. 3V / 0.7 mA

Input requirements:

$\leq 200 \Omega / 0.2 \text{ V}$ for ON; $\geq 2 \text{ k}\Omega / 1 \text{ V}$ for OFF

Detecting level: 0.6 V

- Excitation: 8 V

Sensing voltage/current: Approx. 6V / 1.5 mA

Input requirements:

$\leq 600 \Omega / 1 \text{ V}$ for ON; $\geq 4 \text{ k}\Omega / 3 \text{ V}$ for OFF

Detecting level: 2 V

- Excitation: 12 V

Sensing voltage/current: Approx. 9V / 2.3 mA

Input requirements:

$\leq 400 \Omega / 1 \text{ V}$ for ON; $\geq 2 \text{ k}\Omega / 3 \text{ V}$ for OFF

Detecting level: 2 V

■ VOLTAGE PULSE

Maximum frequency: 0 – 200 kHz

Waveform: Square or sine

Input impedance: $\geq 10 \text{ k}\Omega$

Input amplitude: Min. 0.1 Vp-p, max. 100 V p-p (30 V rms, 42.4 V peak or 60 V DC for UL approval)

Max. voltage between input terminals: 100 V (30 V rms, 42.4 V peak or 60 V DC for UL approval)

Detecting levels: -2 – +4 V

(Detecting voltage in the internal circuit)

■ TWO-WIRE CURRENT PULSE

Maximum frequency: 0 – 200 kHz

Input resistance: Receiving resistor 100 Ω

Input range: 0 – 25 mA

Input amplitude: Min. 4 mA, max. 20 mA

Detecting levels: -2 – +4 V

(Detecting voltage in the internal circuit)

■ RS-422 LINE DRIVER PULSE

Maximum frequency: 0 – 200 kHz

Receiver: Conforms to RS-422

OUTPUT SPECIFICATIONS

■ DC CURRENT

Maximum range: 0 – 20 mA DC

Minimum span: 1 mA

Conformance range: 0 – 24 mA DC

(Negative overrange current below 0 mA is not available.)

Offset: Lower range can be any specific value within the output range provided that the minimum span is maintained.

Load resistance: Output drive 12 V maximum;

■ DC VOLTAGE

Narrow Spans (mV)

Maximum range: -2.5 – +2.5 V DC

Minimum span: 250 mV

Conformance range: -3 – +3 V DC

Wide Spans (V)

Maximum range: -10 – +10 V DC

Minimum span: 1 V

Conformance range: -11.5 – +11.5 V DC

Offset: Lower range can be any specific value within the output range provided that the minimum span is maintained.

Load resistance: Output drive 1 mA maximum

INSTALLATION

Power Consumption

- AC Power input:

Approx. 3 VA at 100 V

Approx. 4 VA at 200 V

Approx. 5 VA at 264 V

• **DC power input:** Approx. 3 W

Operating temperature: -25 to +65°C (-13 to +149°F)

Max. 55°C (131°F) for UL approval

Operating humidity: 0 to 95 %RH (non-condensing)

Mounting: DIN rail

Weight: 100 g (3.53 oz)

PERFORMANCE

Accuracy: Input accuracy + output accuracy

Input accuracy: ± 0.03 % of input range (Table 2)

Output accuracy: ± 0.03 % of output range (When the output span is not more than 2 mA, add 0.1 % to the accuracy)

The input accuracy is inversely proportional to the input span; while the output accuracy is likewise inversely proportional to the output span.

Temp. coefficient: ± 0.015 %/°C (± 0.008 %/°F) of I/O range at -5 to +55°C [23 to 131°F]

Response time: 0.5 sec. + one pulse cycle or sampling time, whichever is larger (0 - 90 %)

Line voltage effect: ± 0.1 % over voltage range

Insulation resistance: ≥ 100 M Ω with 500 V DC

Dielectric strength: 1500 V AC @1 minute (input to output to power to ground)

CALCULATION EXAMPLES OF OVERALL ACCURACY

[Example] Open collector input, 0 - 50 kHz; 1 - 5 V output.

Selected freq. range (100 kHz) \div Input span (50 kHz) \times

Accuracy (0.03 %) = 0.06 % (Input accuracy)

Selected output range (20 V) \div Output span (4 V) \times

Accuracy (0.03 %) = 0.15 % (Output accuracy)

Overall accuracy = 0.06 + 0.15 = ± 0.21 %

STANDARDS & APPROVALS

CE conformity:

EMC Directive (2004/108/EC)

EMI EN 61000-6-4: 2007

EMS EN 61000-6-2: 2005

Low Voltage Directive (2006/95/EC)

EN 61010-1: 2001

Installation Category II

Pollution Degree 2

Input or output to power: Reinforced insulation (300 V)

Input to output: Basic insulation (300 V)

Approval:

UL/C-UL general safety requirements

(UL 61010-1, CAN/CSA-C22.2 No.1010-1)

EXTERNAL VIEW

FRONT VIEW

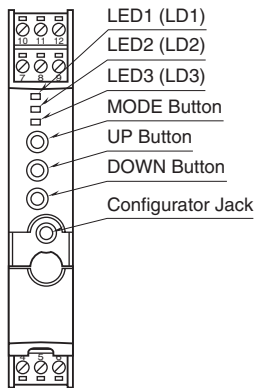

SIDE VIEW

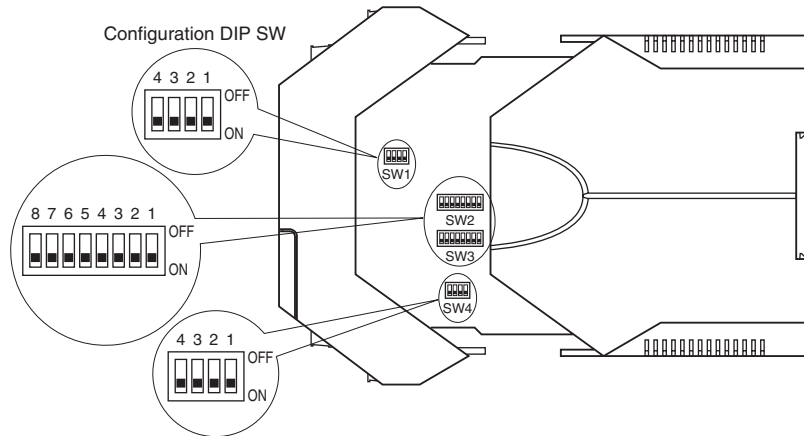

ADJUSTING DETECTING LEVEL

A specific sensitivity scale is applied according to the pulse amplitude by setting up the DIP switch and PC Configurator Software (model: M3CFG). The scaled input voltage is then compared to the detecting level at -2.00 through +4.00 V. For open collector input, be sure to adjust the voltage to following values if it has been changed for other input types.

Detecting level:

- 0.6 V (4 V excitation)
- 2 V (8 V / 12 V excitation)

With DC coupling, the scaled maximum input voltage level must be higher than and the scaled minimum input voltage level must be lower than the detecting level so that the pulse state is accurately detected.

Table 1

PULSE AMPLITUDE	MAX. VOLTAGE AT INPUT TERMINALS	SENSITIVITY SCALE
50 – 100V p-p	100V *1	1/20
25 – 50V p-p	50V *2	1/10
10 – 25V p-p	25V	1/5
5 – 10V p-p	10V	1/2
1 – 5V p-p	5V	1
0.5 – 1V p-p	1V	5
0.1 – 0.5V p-p*3	0.5V	10
Open collector Mechanical contact 2-wire current pulse	----	1

*1. 30V rms, 42.4V peak or 60V DC for UL approval

*2. 30V rms, 42.4V peak or 50V DC for UL approval

*3. Input frequency ≤50 kHz

Choose the noise filter type appropriate for the selected frequency range to ensure the described accuracy. Time constant is set to 50 msec. with the 'large' noise filter setting and to 10 msec. with the 'small' noise filter setting.

Table 2

FREQUENCY RANGE	NOISE FILTER
0 – 10 Hz	Small
0 – 100 Hz	Small
0 – 1 kHz	Small
0 – 10 kHz	None
0 – 200 kHz	None

EXTERNAL DIMENSIONS & TERMINAL ASSIGNMENTS unit: mm (inch)

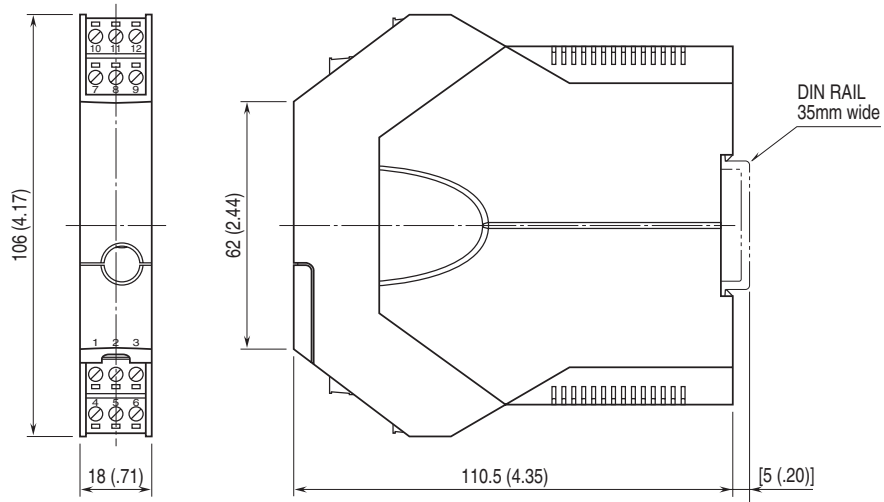

• When mounting, no extra space is needed between units.

SCHEMATIC CIRCUITRY & CONNECTION DIAGRAM

DC POWERED TYPE

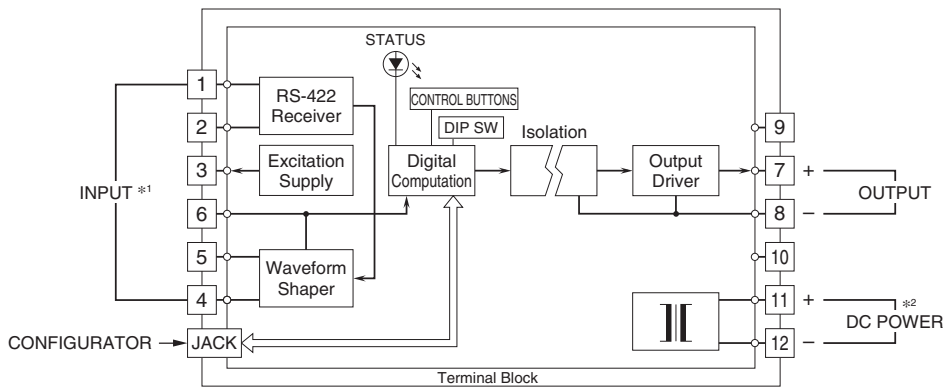

AC POWERED TYPE

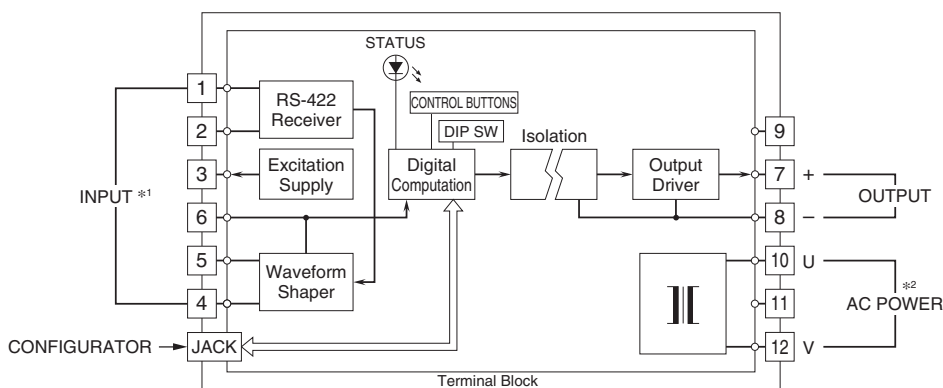

*2. Be aware that the AC power and DC power connect to different terminals.

*1. Input Connection Examples

Open Collector

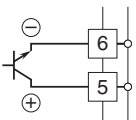

Voltage Pulse

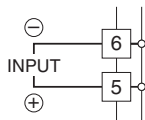

Two-wire Current Pulse

• Built-in Excitation

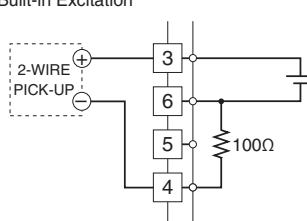

Excitation Supply

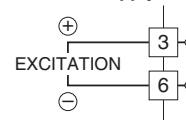

Mechanical Contact

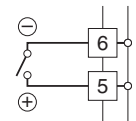

RS-422 Line Driver Pulse

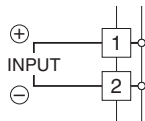

External DC Supply

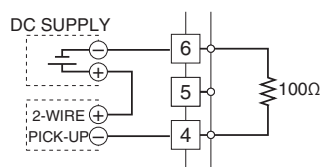

Specifications are subject to change without notice.