

# KAMIO-WL01/SD01

- COTS (Commercial off-the-shelf) 802.11b wireless LAN module for the KAMIO-CB01 carry board
- COTS (Commercial off-the-shelf) MiniSD module for the KAMIO-CB01 carry board

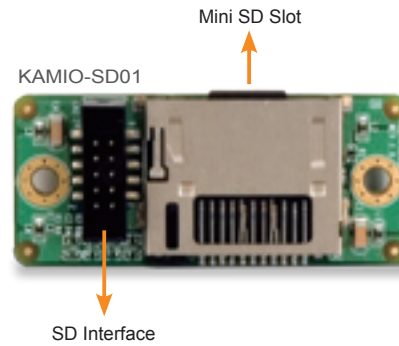
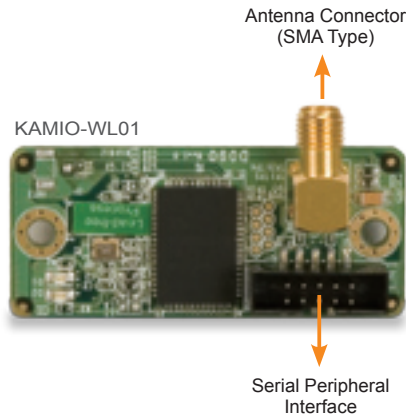

## Specifications

### KAMIO-WL01

- Compliant with 802.11b standard for 2.4GHz Wireless LAN
- Up to 11 Mbps data transfer rate in 802.11b mode of operation
- OEM option: 802.11g SD interface
- Connector type: 10 pin 2.0mm box header
- Antenna: With 100mm length 2dBi SMA type antenna
- Interface: SPI (Serial peripheral Interface)
- Chipset: Philips BGW200
- OS support for Windows® CE
- Low power consumption in standby mode: < 2mW
- Operating Voltage: 3.3V
- Dimensions: 50mm x 22mm x 11.5 mm

### Dimensions (Unit : mm)

#### KAMIO-WL01

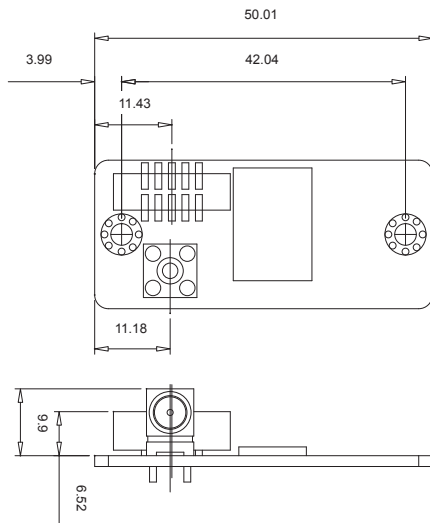

### KAMIO-SD01

- Support to read Mini SD card
- Up to 80X data transfer rate
- OS support for Windows® CE
- Interface: MMC/SD
- Connector type: 10 pin 2.0mm box header
- Operating Voltage: 3.3V
- Dimensions: 50mm x 22mm x 3.9 mm

#### KAMIO-SD01

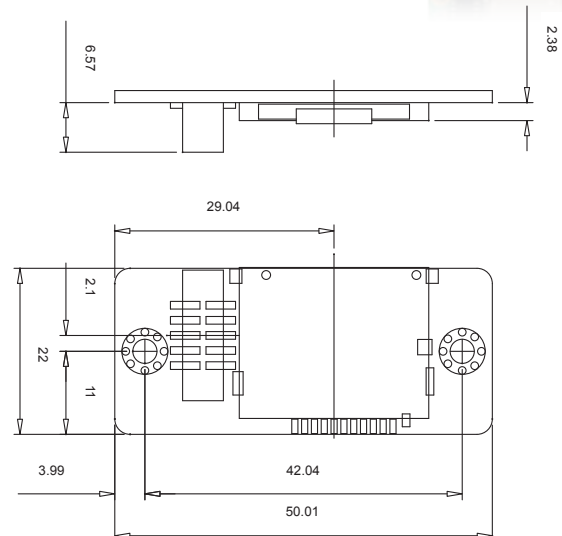

## Ordering Information

Part No.	Description
KAMIO-WL01-R10	802.11b wireless LAN module for the KAMIO-CB01 carry board
KAMIO-SD01-R10	MiniSD module for the KAMIO-CB01 carry board

## Packing List

KAMIO-WL01	1 x KAMIO-WL01 module card 1 x Hardware user manual 1 x Connection cable 1 x 100mm 2dBi SMA type antenna	KAMIO-SD01	1 x KAMIO-SD01 module card 1 x Hardware user manual 1 x Connection cable
------------	---	------------	--

- 1 Single Board Computer
- 2 VIDEO CARD
- 3 Xscale Solutions
- 4 Open HMI
- 5 VITO Universal Controller
- 6 DINO BLADE
- 7 LCD Product Series
- 8 Embedded System
- 9 Industrial Computer Chassis
- 10 Power Supply
- 11 Peripherals