

➤ AM4011

Processor AMC Module based on Intel® Core™ 2 Duo



powered by Embedded
Multi-Core Processor

AdvancedMC™

AdvancedTCA®

μTCA™

- **Ultra Performance**
Intel® Core™ 2 Duo with 1.5 GHz
- **Ultra Capacity**
Up to 4 GB memory DDR2 400 MHz
Up to 8 GB NAND Flash
- **Ultra Flexibility**
Flexible Gigabit and PCI Express fabric interface

➤ First class performance AMC module

Kontron's AdvancedMC processor module AM4011 provides outstanding performance in conjunction with comprehensive AMC interconnect capabilities designed according to the PICMG specifications AMC.0, AMC.1, AMC.2, AMC.3.

➤ Ultra Performance

The AM4011 is a highly integrated CPU board implemented as a Single Mid-size or Full-size Advanced Mezzanine Card (AMC) Module. The design is based on the Intel® Core™2 Duo processor in 65 nm technology with 64 kB L1 and 4 MB L2 cache in a 479 FCBGA package combined with the Intel® 3100 server-class chipset providing a front side bus (FSB) of 667 MHz.

➤ Ultra Capacity

The board includes up to 4 GB registered Double Data Rate (DDR2) memory with Error Checking and Correcting (ECC) running at 400 MHz. Two dual Gigabit Ethernet controllers each utilizing a x4 lane PCI Express interconnection to the Intel® 3100 chipset ensure maximum data throughput between processor and memory. The AM4011 further provides up to 8 GB Flash memory via a USB 2.0 NAND Flash Controller.

➤ Ultra Flexibility

Supporting the PICMG sub-specifications AMC.1/.2/.3 the AM4011 ensures a comprehensive set of interconnecting capabilities to the AMC Carrier. A x4 PCI Express lane according to AMC.1 guarantees high throughput for I/O intensive applications. The dual Gigabit Ethernet controller realizing the AMC.2 interconnect utilizes a x4 lane PCI Express interface to the 3100 chipset ensuring maximum packet performance. Two SATA ports compliant to AMC.3 allow flexible usage models of the AM4011 depending on the application requirements. The AM4011 offers comprehensive front panel connectivity by 2x GbE RJ45 ports, 1x USB port, an RS232 interface realized via a mini 10-pin connector.

➤ AMC everywhere

A comprehensive range of 'AMC everywhere' ATCA boards, such as ATCA carrier boards, CPU and hub boards are complementing Kontron's AMC product portfolio including the AM4011 module. Optimized for high-performance, packetbased telecom systems, the AM4011 is targeted towards, but not limited to telecom applications such as radio network controllers, storage control, routing and switching solutions in ATCA systems. Beyond the usage in ATCA systems the AM4011 complies to the MicroTCA standard dedicated for cost optimized communication applications.

➤ Reliability

The careful design and selection of high temperature resistant components together with the elaborated heat sink construction ensures a high product availability. This, along with a high level of scalability, reliability, and stability, makes this state-of-the-art product a perfect core technology for long-life embedded applications.

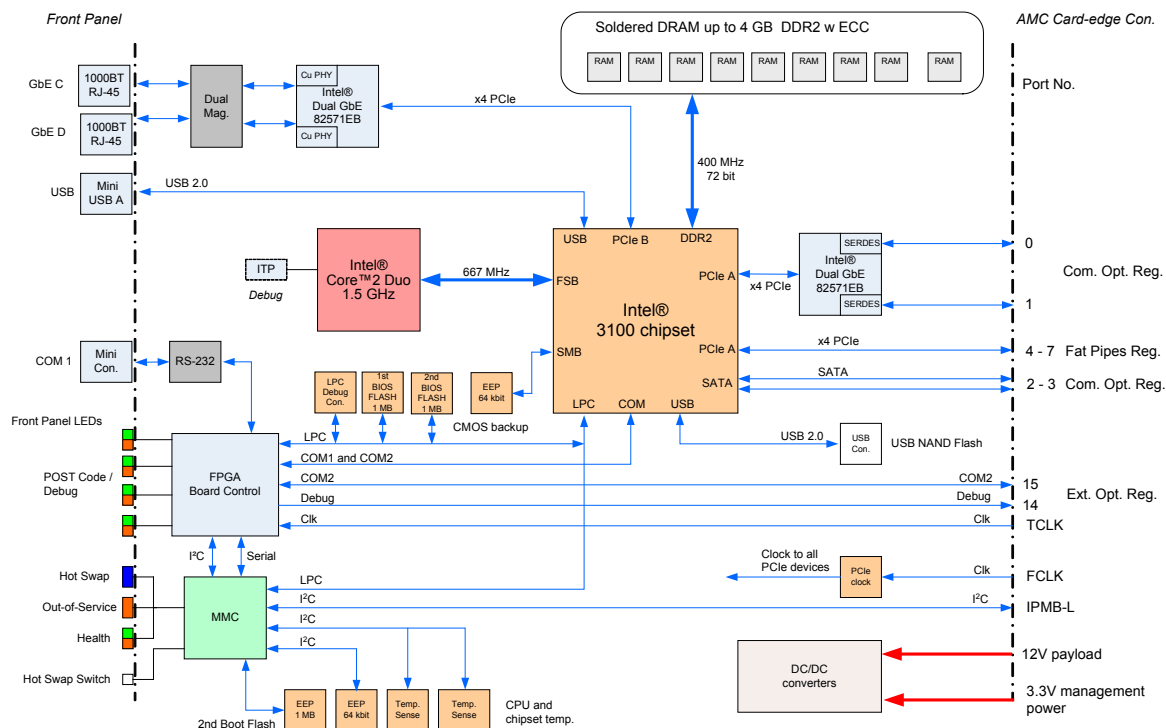

► Specification

System Processor	
	Intel® Core™2 Duo L7400 (LV), 1.5 GHz, 667 MHz FSB, 4 MB L2 cache The processor is passive cooled with a fanless heatsink. Forced air cooling at a specific flow rate is required.
Memory	
System memory:	Up to 4 GByte (soldered) registered DDR2 400 MHz with ECC
NAND Flash:	Up to 8 GByte NAND Flash via onboard USB 2.0 Flash controller
Flash (BIOS):	Two redundant 1 MB Firmware hubs (FWH)
EPROM:	Serial EEPROM (24LC64) 64 kbit
Onboard Controller	
Intel® 3100 chipset with integrated Memory and I/O Controller Hub:	Three x4 PCI Express ports, DDR2 SDRAM memory controller with ECC, six SATA 150 ports, four USB 2.0 ports, two UARTs, RTC, Interrupt Controller, Timer
Gigabit Ethernet:	Two Intel® 82571EB dual Gigabit Ethernet PCI Express bus controller
Watchdog:	FPGA based, software configurable, two-stage Watchdog with programmable timeout ranging from 125 msec to 256 sec in 12 steps.
MMC:	Microcontroller with on-chip 512 kB Flash and 40 kB RAM, ext. 1 MB SPI Flash, 64 kbit EEPROM
AMC System Interconnect	
PCI Express:	One x4 PCI Express interface AMC fat pipes region port 4-7
Gigabit Ethernet:	1x 1000BASE-BX (SerDes) on AMC ports 0-1 (Common Options Region)
Serial ATA:	2x Serial ATA 150 ports on AMC ports 2-3 (Common Options Region) and 2x Serial ATA 150 ports on AMC ports 12-13 (Extended Options Region)
Serial Interface:	1x Serial Port (COM2) on AMC port 15 (Extended Options Region)
Front Panel	
	One USB 2.0 port on a 5-pin, mini USB type A connector One Serial port (COM1) with RS-232 signal level on a mini 10-pin connector Two Gigabit Ethernet ports on two RJ-45 connectors Three Module Management LEDs Four User-Specific LEDs
MMC Module Management Controller	
	Microcontroller with 40 kB RAM and redundant 512 kB Firmware Flash with automatic roll-back strategy. The MMC carries out IPMI commands such as monitoring several onboard temperature conditions, board voltages and the power supply status, and managing hot swap operations. The MMC is accessible via a local IPMB (IPMB-L) and two host Keyboard Style Interfaces (KCS).
Compliance	
ATCA:	PICMG 3.0 AdvancedTCA Base Specification R2.0
MicroTCA:	PICMG MTCA.0 Micro Telecommunications Comp. Architecture R1.0
AMC:	PICMG AMC.0: Advanced Mezzanine Card Specification R2.0 PICMG AMC.1: PCI Express and Advanced Switching R1.0 PICMG AMC.2: Gigabit Ethernet R1.0 PICMG AMC.3: Storage Interfaces R1.0
IPMI:	IPMI Intelligent Platform Management Interface Spec. V2.0 IPMI - Platform Management FRU Information Definition V1.0
PCI Express:	PCI Express Base Specification Revision 1.0a
Serial ATA:	Serial ATA 2.5 Specification
CE:	EN55022, EN55024, EN61000-6-2/-6-3, EN300386, EN60950-1
Vibration/Shock:	IEC60068-2-6 / IEC60068-2-27
Climatic Humidity:	IEC60068-2-78
WEEE:	Directive 2002/96/EC
RoHS:	Directive 2002/95/EC
Power Consumption	
AM4011 with Core 2 Duo, 1.5 GHz, 2 GB	max. 36 W
General	
Dimensions:	181.5 mm x 73.5 mm x 18.96 mm (Mid-size/Single-width), 181.5 mm x 73.5 mm x 28.95 mm (Full-size/Single-width)
MTBF:	223,951 h acc. Bellcore Issue 6, Ground Benign, Controlled, 30 C
Software Support	
	AMI BIOS, BIOS parameters saved in EEPROM, Boot order defined via MMC Serial over Lan, Support for Redhat Linux, WRLinux PNE 2.0 (Q3/2008), VxWorks 6.6 SMP (Q3/2008)
Environmental	
Operating temp.:	-5°C to +55°C (depending on system environment)
Storage temp.:	-40°C to +70°C
Humidity:	Operational: 5%-90% (non-condensing) Non-Operating: 5%-95% (non-condensing)

► Ordering Information

Article	Description
	Processor AMC
AM4011-1.5GHz-2M-mid	PrAMC, Intel® Core™ 2 Duo (LV), 1.5 GHz, 667 MHz FSB, 2 GB memory
AM4011-1.5GHz-4M-mid	PrAMC, Intel® Core™ 2 Duo (LV), 1.5 GHz, 667 MHz FSB, 4 GB memory
	Software
LIN-BSP-AM4011	Generic Linux Board Support Package, Documentation
	Accessories
FLASH-xxx	NAND-Flash in various capacities

► AM4011 Platforms



► Corporate Offices

Europe, Middle East & Africa

Oskar-von-Miller-Str. 1
85386 Eching/Munich
Germany
Tel.: +49 (0)8165/ 77 777
Fax: +49 (0)8165/ 77 219
sales@kontron.com

North America

14118 Stowe Drive
Poway, CA 92064-7147
USA
Tel.: +1 888 294 4558
Fax: +1 858 677 0898
sales@us.kontron.com

Asia Pacific

17 Building, Block #1, ABP.
188 Southern West 4th Ring Road
Beijing 100070, P.R.China
Tel.: + 86 10 63751188
Fax: + 86 10 83682438
kcn@kontron.cn

Kontron Modular Computers GmbH

Sudetenstr. 7
87600 Kaufbeuren
Germany
Tel.: +49 (0)8341/ 803-0
Fax: +49 (0)8341/ 803-499
sales@kontron.com