

Mating Connectors

H11
H15
H15 S4

Description

All 19" cassette type converters are equipped with either H11-, H15-, H15 S2 or H15 S4 male connectors. Mating female connectors are available as accessories according to the following tables. The four H-type connector versions are specially designed for power supply applications, capable of handling high operating currents. The connectors have an integrated code key system allowing many coding possibilities. Modules with high output current normally use two contacts in parallel to keep the voltage drop across the connector as low as possible.

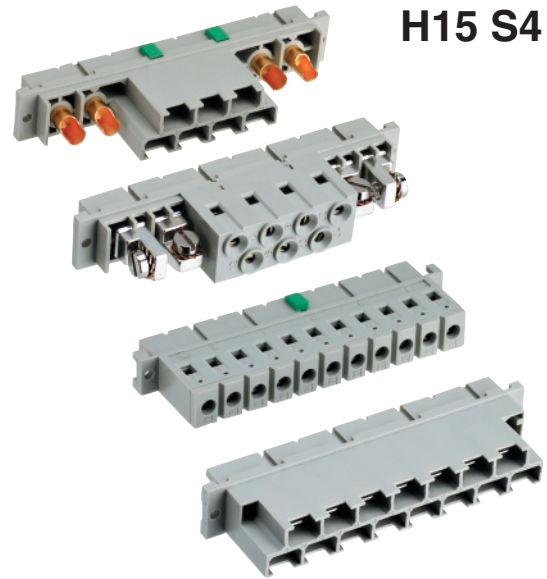

H11 Connector

This connector has eleven contacts in one vertical column marked 2 to 32. Mating and mounting conditions are according to DIN 41612. The connector contacts are hard-silver-plated and correspond to quality class 1, with respect to electrical and mechanical life time.

Table 1: H11 Connector Survey

Female connector type	Part no.	Description of terminals	Integrated coding
STV-H11-F/CO	HZZ 00101	Faston straight 6.3 × 0.8 mm	yes
STV-H11-FS/CO	HZZ 00104	Faston straight 6.3 × 0.8 mm, solderable (short moulding)	yes
STV-H11-FSR/CO	HZZ 00102	Screw terminals, 90°, 2.5 mm ² (AWG 13) max,	yes
STV-H11-FB/CO ¹	HZZ 00103	Solder pin 5.2 mm, Ø 1.6 mm	yes
STV-H11-FBER/CO ²	HZZ 00113	Solder pin 4.3 mm, Ø 1.0 mm	yes
STV-H11-FP/CO ²	HZZ 00111	Press fit 6.5 mm, Ø 1.0 mm	yes
STV-H11-FBG/CO ²	HZZ 00199	Solder pin 5.2 mm, Ø 1.6 mm, gold-plated contacts	yes

¹ See also matching Flexi-PCB for PCB mounting of converters (see *Mounting Supports*)

² Available on request

This connector type (male version) is used in the following converter series (case size):

H (H02), M (M02), SR (L01) and PSL (L04).

Table of Contents

	Page		Page
Description	1	Extraction Tool for High Current Contacts	6
H11 Connector	1	Connector Retention Clip V	6
H15 Connector	3	Connector Retention Bracket CRB	7
H15 S2, H15 S4 Connector	4	Cable Hood	7
Technical Data	5	Cable Hood Retention Bracket CHRB	7
Code Key System	6		

Mechanical Dimensions

All dimensions in mm, tolerances ± 0.2 mm unless otherwise specified

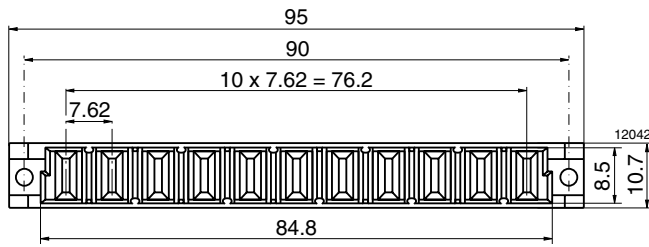

Fig. 1
H11 frontal view, relating to figures below

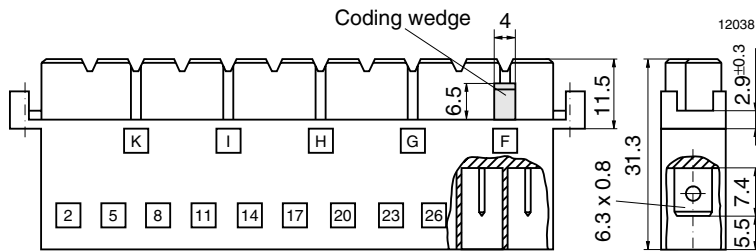

Fig. 2
STV-H11-F/CO,
Faston cable terminals 6.3×0.8 mm

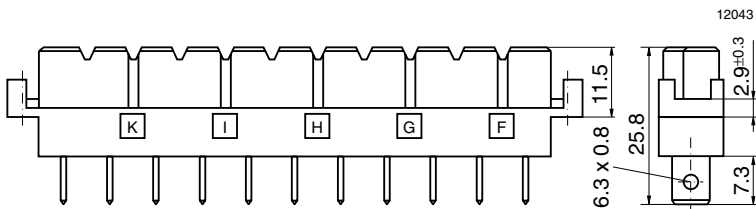

Fig. 3
STV-H11-FS/CO,
Faston cable terminals 6.3×0.8 mm,
solderable (short moulding)

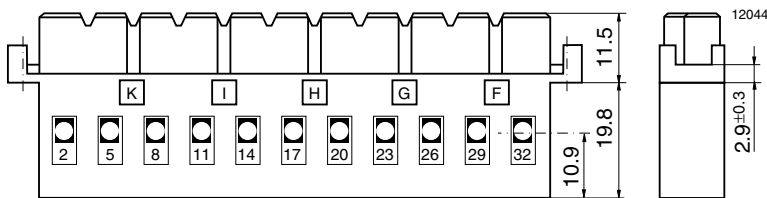

Fig. 4
STV-H11-FSR/CO,
screw terminals (max. 2.6 mm^2 /AWG 13)

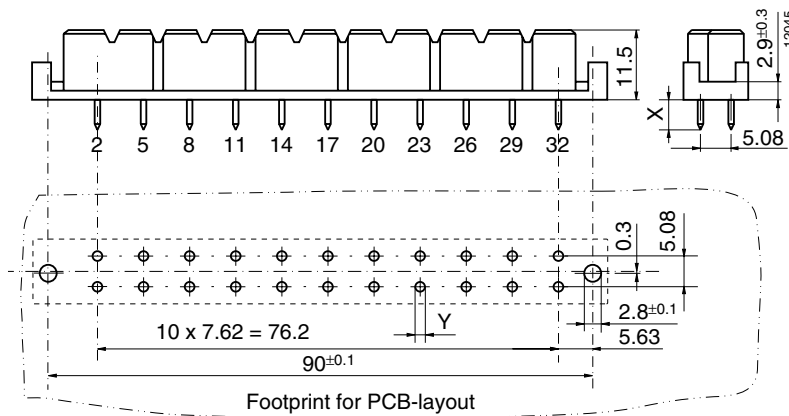

Fig. 5
STV-H11-FB/CO,
soldering pins $X = 5.2 \quad Y = \varnothing 1.6$
STV-H11-FBG/CO,
soldering pins $X = 5.2 \quad Y = \varnothing 1.6$
STV-H11-FBER/CO,
soldering pins $X = 4.3 \quad Y = \varnothing 1.0$
STV-H11-FP/CO,
press insert pins $X = 6.5 \quad Y = \varnothing 1.0$

H15 Connector

This connector has fifteen contacts in two vertical columns marked 4 to 32 and is designed to meet DIN 41612. The connector contacts are hardsilver-plated and correspond to quality class 1, with respect to electrical and mechanical life time.

This connector type (male version) is used in the following converter series (case size):

PSS (S01), S (S02), Q (Q01) and for PSK (K01) and K (K02) only for output current ≤ 18 A.

Table 2: H15 Connector Survey

Female connector type	Part no.	Description of terminals	Integrated coding
STV-H15-F/CO	HZZ 00106	Faston straight 6.3×0.8 mm	yes
STV-H15-FSR	HZZ 00107	Screw terminals, 90° , 2.5 mm^2 (AWG 13) max.	no
STV-H15-FB/CO	HZZ 00112	Solder pin 4.0 mm, $\varnothing 1.6$ mm	yes
STV-H15-FP/CO ¹	HZZ 00117	Press fit 4.5 mm, $\varnothing 1.0$ mm (double pin version)	yes
STV-H15-FBG/CO ¹	HZZ 00197	Solder pin 4.0 mm, $\varnothing 1.6$ mm, gold-plated contacts	yes
STV-H15-FWS/CO	HZZ 00114	Solder pin 10.1 mm, $\varnothing 1.6$ mm, 90° bent contacts	yes

¹ Available on request

Mechanical Dimensions

All dimensions in mm, tolerances ± 0.2 mm unless otherwise specified

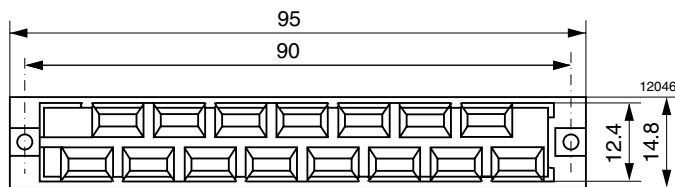

Fig. 6
H15 frontal view,
relating to figures below

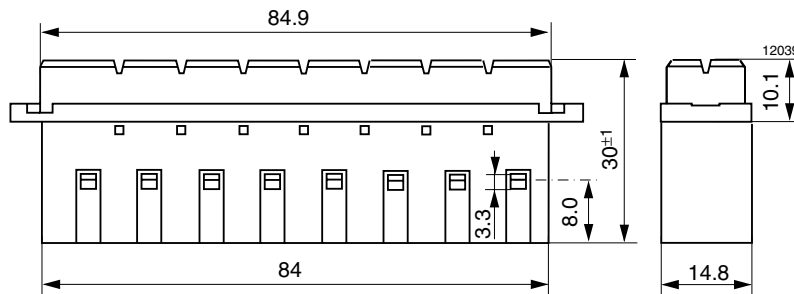

Fig. 7
STV-H15-FSR,
Screw terminals, no coding
STV-H15-F/CO,
Faston cable terminals 6.3×0.8 mm
(identical dimensions, but not shown)

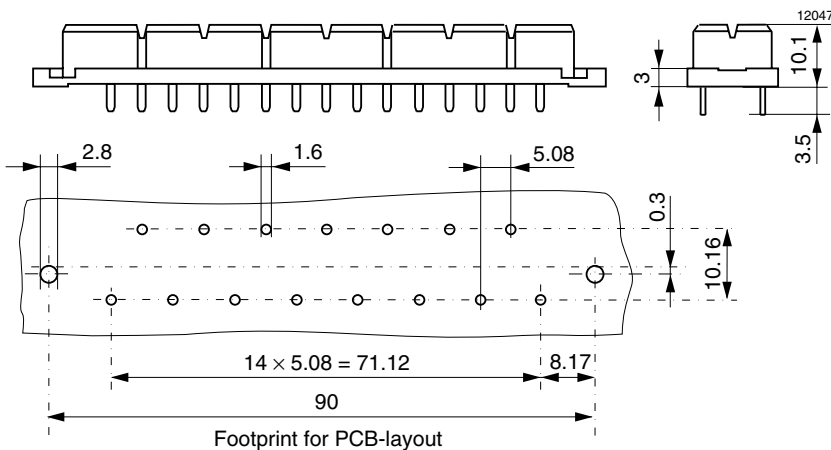

Fig. 8
STV-H15-FB/CO,
soldering pins

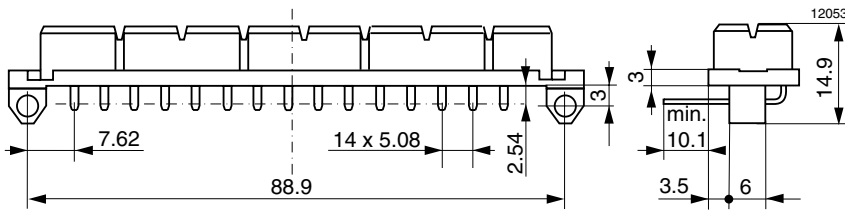

Fig. 9
STV-H15-FWS/CO
Solder pins for pcb mounting

H15 S2, H15 S4 Connector

This special connector is a derivative of the H15 having seven standard contacts as above, combined with two (H15 S2) or four (H15 S4) high current contacts according to DIN 41626. The high current contacts are specially designed to handle currents from 20 A up to 40 A. They correspond to quality class 1, with respect to electrical and mechanical life time. The contact material is high quality Beryllium-Copper (CuBe treated) with a gold-plated surface.

To install the high current contacts carefully follow the assembly instructions. It is extremely important to solder cables, screw cable terminals or heat shrink sleeves to high current jacks first, before inserting them into the moulding. Paralleled converters should preferably be interconnected on current bars or at a star point.

Using screw versions, the two outer high current jacks may be inserted at a 90° angle in order to prevent possible short

circuits between the cable terminals, especially in applications with high vibration environment. Heat shrink sleeves might be necessary for further isolation purposes or to keep clearance and creepage distances at specified levels.

An Extraction Tool allows removal of the high current contacts for replacement (see: *Extraction Tool*).

Caution: The use of an adequate cable strain relief device (e.g. Cable Hood etc.) is essential in order to protect the high current contact jacks from damage. Never screw, solder or manipulate these contacts when the connector is plugged into the male connector! The use of highly flexible cables is strongly recommended.

This connector type (male version) is used in the following converter series (case size):

PSK (K01), K (K02) and P with output current ≥20 A.

Table 3: H15 S2/S4 Connector Survey

Female connector type	Part no.	Description of terminals coding	Integrated
STV-H15 S2-F/CO	HZZ 00115	11 Faston straight 6.3 × 0.8 mm, set of 2 solder jacks ¹	yes
STV-H15 S2-FSF/CO	HZZ 00116	11 Faston straight 6.3 × 0.8 mm, set of 2 screw jacks ¹	yes
STV-H15 S4-F/CO	HZZ 00105	7 Faston straight 6.3 × 0.8 mm, set of 4 solder jacks ¹	yes
STV-H15 S4-FSF/CO	HZZ 00110	7 Faston straight 6.3 × 0.8 mm, set of 4 screw jacks ¹	yes
STV-H15 S4-FLS/CO	HZZ 00109	7 screw terminals, 90°, 2.5 mm ² , set of 4 solder jacks ¹	yes
STV-H15 S4-FSR/CO	HZZ 00108	7 screw terminals, 90°, 2.5 mm ² , set of 4 screw jacks ¹	yes

¹ Spare set of high current jacks are available on request

Delivery content: H15 S2 (S4) moulding, two (four) high current jacks and assembly instructions. Screw versions also include four M4 screws with washers and heat shrink sleeves.

Mechanical Dimensions

All dimensions in mm, tolerances ±0.2 mm unless otherwise specified

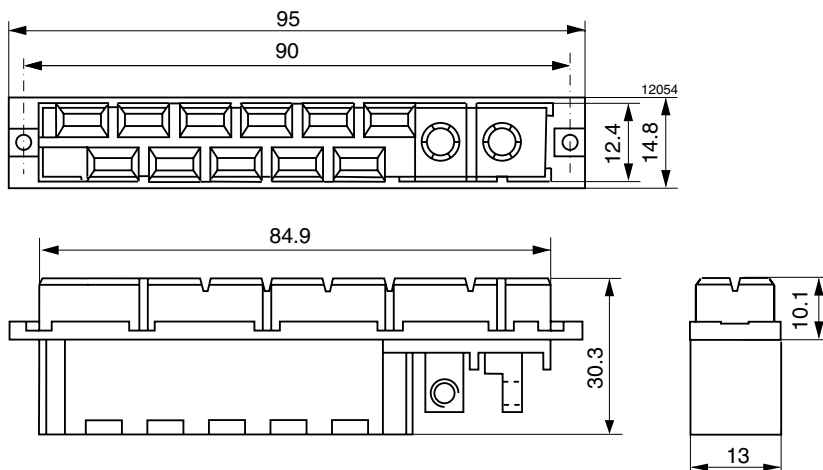

Fig. 10
STV-H15 S2-FSF/CO
Faston cable terminals and two high current screw terminals (solder terminals see H15 S4)

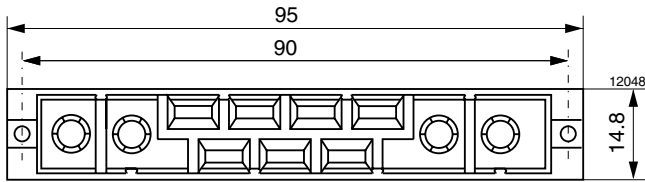

Fig. 11
H15 S4 frontal view,
relating to figures below

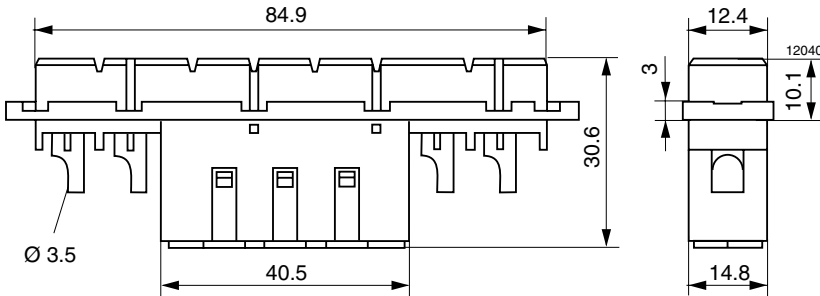

Fig. 12
STV-H15 S4-FLS/CO,
screw terminals and four high current
soldering terminals
STV-H15 S4-FSR/CO,
screw terminals and four high current
screw terminals (not shown)

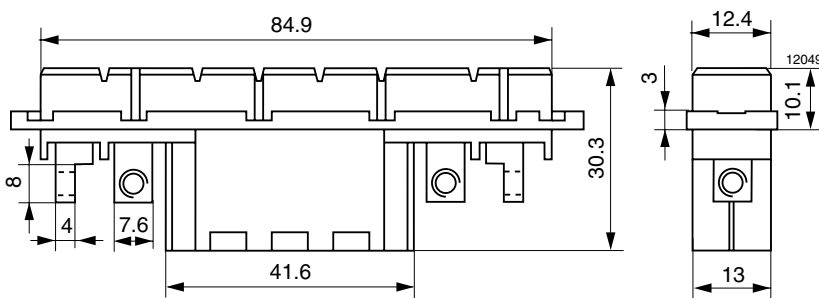

Fig. 13
STV-H15 S4-FSF/CO,
Faston cable terminals and four high
current screw terminals
STV-H15 S4-F/CO
Faston cable terminals and four high
current soldering terminals (not shown)

Technical Data

Table 4: Connector data

Type	H11	H15	H15 S2/H15 S4	
			Standard	High current
Mechanical data				
Number of poles	11	15	11/7	2/4
Mating cycles	500	500	500	500
Insertion/withdrawal forces max.	80 N	90 N	90 N	10/1.6 N
Electrical data				
Clearance distance contact/ground	≥4.5 mm	≥4.5 mm	≥4.5 mm	
Creepage distance contact/contact	≥8.0 mm	≥8.0 mm	≥8.0 mm	
Test voltage V _{rms}	3100	3100	3100	
Operation voltage V AC	500	500	500	
Operation current per contact	T _A 20°C 20 A T _A 70°C 17 A T _A 95°C 14 A	15 A 12 A 9 A	15 A 12 A 9 A	40 A 35 A 25 A
Contact resistance	≤8 mΩ	≤8 mΩ	≤8 mΩ	≤1 mΩ
Isolation resistance at 100 V DC	≥10 ¹² Ω	≥10 ¹² Ω	≥10 ¹² Ω	
Miscellaneous data				
Operating temperature	-55...125°C	-55...125°C	-55...125°C	
Contact surface	6 μm Ag	6 μm Ag	6 μm Ag	1.3 μm Au
Moulding material	PBTP/PC	PBTP/PC	PBTP	
Flammability	UL 94V-0/UL 94 V-1	UL 94 V-0/UL 94 V-1	UL 94 V-0	
Approvals				

Code Key System

An efficient coding system is of great importance and cannot be valued highly enough in complex electronic systems. Since power supplies handle high currents and voltages any false connection could not only be extremely dangerous but also quite costly.

This integrated polarizing system allows effortless coding by the simple insertion of Coding Wedges into the female connector mouldings. The corresponding counter-parts, i.e. the coding tabs of the male moulding just have to be broken off to match the right female part. Major advantages are high mechanical stability and ease of handling. The H11 connectors have 10 and the H15 connectors have 8 coding positions. Using 4 coding wedges results in 210 (H11) respectively 70 (H15) different coding possibilities. Coding wedges are available as accessories to female connectors with the following part number:

Description: Coding wedge (Codierkeil)
Delivery content: 5 pcs.
Part Number: HZZ 00202

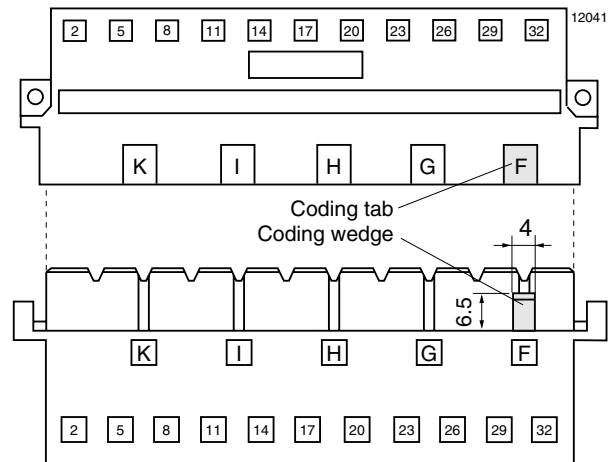

Fig. 14
Integrated code key system

Extraction Tool for High Current Contacts

High current plugs and jacks can be disassembled from the moulding by means of a special Extraction Tool (H15 S2, H15 S4). Holding the extraction tool over the centre of the connector's female contact the outer part of the extraction tool should be fed between the moulding and the outside of the female contact itself. This releases the spring clip fixing the contacts, in order to pull the contacts out of their moulding for replacement. If the operation is performed correctly very little force is required. Extreme care should be taken since incorrect procedure and excessive force could damage the tool and/or connector.

This tool is available as an accessory for both screw or solder high current contacts.

Note: In order to avoid damage never manipulate high current contacts when plugged-in!

Description: Extraction Tool
Part Number: HZZ 00150



Fig. 15
Extraction tool

Connector Retention Clip V

The retention clip V is an accessory which guarantees secure connection even under severe vibration, as for example in mobile applications. One connector retention system fits to almost all units and all of the aforementioned connector types.

The following converter series are delivered with pre-punched holes in the back plate for fast field-mounting of retention clips:

H, M, K, PSK, S, PSS and T (Q series only in combination with Mounting Plate Q, see Mounting Supports)

Description: Retention Clips V
Delivery content: 2 pcs.
Part Number: HZZ 01209

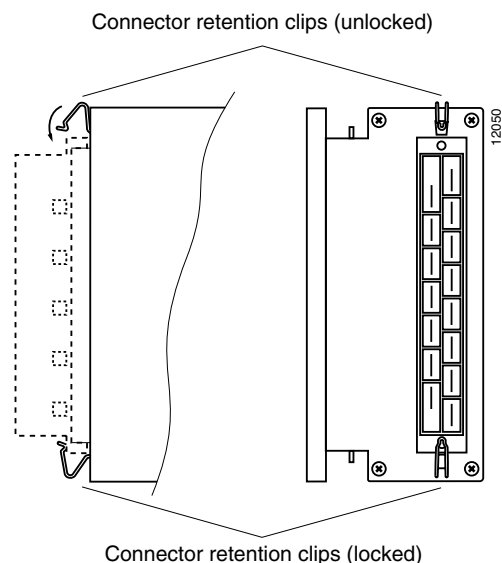

Fig. 16
Connector retention clip

Connector Retention Bracket CRB

An alternative to the above mentioned retention clip V is the connector retention bracket. They are attached to the back plate by one screw each with a torque of 20 to 30 Ncm.

Table 5: Connector Retention Bracket Survey

Connector series	Type Part number	Delivery content
H, M K, PSK S, PSS T	CRB-HKMS HZZ 01216	2 brackets 2 screws 2 washers
Q, P PC	CRB-Q HZZ 01217	

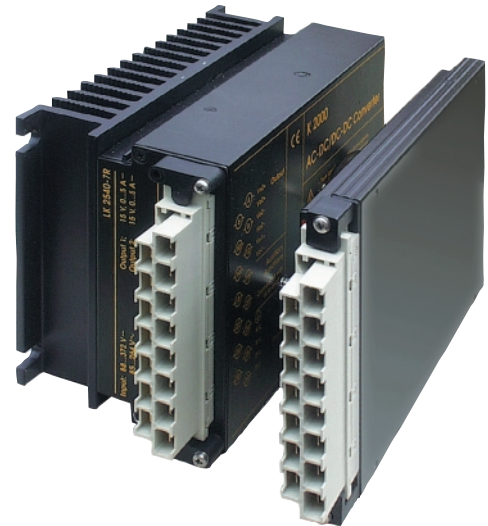

Cable Hood

A cable connector housing or Cable Hood is available for all female H15, H15 S2 and H15 S4 type connectors with faston connectors (Not suited for screw terminals). It serves as a strain relief, isolates connections and protects cables.

Description: KSG-H15/H15 S4

Delivery content: Housing shell, cable duct with covers, cable clip, cable boot and screws

Part number: HZZ 00141

If using the cable hood together with retention clips a special version is available, where both sides of the hood are slightly modified in order to allow for insertion of the clips. The cable hood with retention clips has been tested to withstand vibrations according to IEC 86-2-6: 5 g, 6 directions, 2.5 hours per axis.

Description: KSG-H15/H15 S4-V

Delivery content: Housing shell, cable duct with covers, cable clip, cable boot and screws

Part Number: HZZ 00142

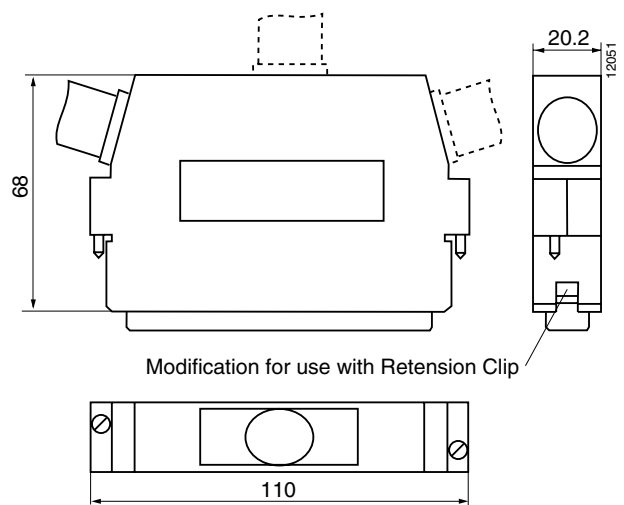

Fig. 17
Cable hood for H15 and H15 S4 connectors

Cable Hood Retention Bracket CHRB

The cable hood can also be fixed to the converter case with two U-shaped cable hood retention brackets.

Description: CHRB-KSG

Delivery content: Two brackets with two screws

Part number: HZZ 01218

