

ICS-8550

Rugged XMC Module Provides 210 MHz ADCs and Virtex-4 Processing Power

Features

- 2 ADC channels (Analog Devices AD9430): 12 bits @ 210 MHz
- Xilinx Virtex-4 FX60 with two IP cores (default logic core, programmable DDC core)
- Hardware Development Kit (HDK) included
- High-speed serial I/O (8 lanes) through XMC connector
- 8-connector Samtec GRF1-J connector (ruggedization levels 1 - 3)
- 8 individual MMCX connectors (ruggedization level 4 & 5)
- Companion to V4DSP 6U VME FPGA and PowerPC Processor
- VxWorks, Linux and Windows device drivers
- Extensive application and technical support available

The ICS-8550 is an XMC form factor digital receiver module intended for Software Defined Radio applications such as communications and radar in benign and hostile environments. The card has been optimized to provide high performance signal conversion capability to XMC equipped host cards such as the V4DSP Dual Virtex-4 & PowerPC Processor. The combination of high performance ADC and FPGA resources allows VHF and UHF signals to be digitized and processed directly on the XMC module. Algorithms such as digital down conversion, FFT, and filtering can be developed to execute in the Virtex-4 FPGA, using the included Hardware Development Kit (HDK). The module is available in five levels of ruggedization, three for air-cooled environments and two for conduction cooled environments. Details of the environmental specifications are available from our web site.

The ICS-8550 HDK includes two core designs, a default logic core and a programmable, dual channel, Digital Down-Converter (DDC) IP core. The default logic core, designed to provide minimum occupancy of the FPGA, includes an A/D interface and data buffering to the high-speed serial outputs and provides a basis for customers to program their own functionality.

The DDC core provides for programmable decimation ratios of 1 through 16, with real or complex outputs. Output selection options include the high-speed serial outputs or the PCI bus. The 18-bit filter coefficients can be independently programmed for each channel; a standard coefficient set is included in the design. Also provided are input and output gain controls, a peak signal detector and a test signal capability.

The ICS-8550 provides the user with up to eight lanes of high-speed serial I/O for communication with XMC equipped carrier cards such as the V4DSP at rates up to 2.5 GBytes/s. The 64/66 PCI interface provides sustained data rates in excess of 400 MBytes/s, while the Pn4 user I/O port allows the user to define direct point to point connections to the FPGA, eliminating interrupt latencies. The latter two interfaces may be used for applications in which the XMC interface cannot be used.

Optional front panel connectors include an 8-plug Samtec GRF1-J connector (for ruggedization levels 1, 2 and 3), or 8 individual MMCX connectors (for ruggedization levels 4 & 5).



ICS-8550 Rugged XMC Module Provides 210 MHz ADCs and Virtex-4 Processing Power

Specifications

Analog Input

- 2 analog inputs, transformer-coupled, AD9430, 12-bit
- Max. sample rate 210 MHz
- 50 Ohm input impedance
- Full scale input +7.7dBm or +1.7dBm, software selectable
- Input bandwidth 2 – 700 MHz (–3dB)
- Max. sampling rate 210 MHz
- Internal sampling clock 409.6 MHz VCXO with dividers
- Min. sampling rate 40 MHz
- Ext. clock LVTTTL or sine wave 0dBm min., 20dBm max., 10 – 420 MHz
- Ext. trigger LVCMOS, rising or falling edge
- SINAD >65dB @ fin <70 MHz
- SFDR >75dB
- Cross-talk <-80dB

General Specifications

- VITA 42 XMC compliant, 8 lanes

Onboard Resources

- Xilinx Virtex-4 FPGA XC4VFX60
- Two IP cores available (default core and programmable DDC core)
- 8-plug Samtec GRF1-J connector (Levels 1 – 3)
- 8 individual MMCX connectors (Level 4 & 5)

I/O Specifications

- PCI 2.2 64-bit, 66 MHz PCI bus interface, universal signaling
- 32 user configurable LVDS I/O pairs directly connect P4 to FPGA

Environmental

- Five build levels available. Air and conduction cooled versions
- -40 to +85 °C operating temperature
- 95% non-condensing humidity

Block Diagram

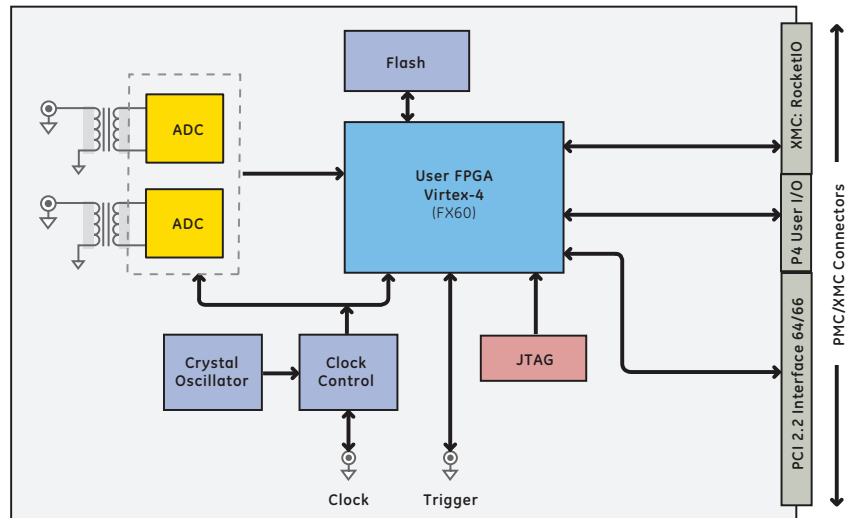

Ordering Information

ICS-8550A-xOO	ICS-8550 with Virtex-4 FX60 FPGA
DRV-8550-VXW	Software device driver for VxWorks operating system
DRV-8550-LX	Software device driver for Linux operating system
DRV-8550-WIN	Software device driver for Windows operating system
DRV-8550-SCA	SCA compliant driver
HDK-8550	Hardware Development Kit for FPGA development by user, including default core and dual-channel programmable DDC core

About GE Intelligent Platforms

GE Intelligent Platforms, a General Electric Company (NYSE: GE), is an experienced high-performance technology company and a global provider of hardware, software, services, and expertise in automation and embedded computing. We offer a unique foundation of agile, advanced and ultra-reliable technology that provides customers a sustainable advantage in the industries they serve, including energy, water, consumer packaged goods, government and defense, and telecommunications. GE Intelligent Platforms is a worldwide company headquartered in Charlottesville, VA and is part of GE Home and Business Solutions. For more information, visit www.ge-ip.com.

GE Intelligent Platforms Contact Information

Americas: **1 800 433 2682** or **1 434 978 5100**

Global regional phone numbers are listed by location on our web site at www.ge-ip.com/contact

www.ge-ip.com/sensorprocessing

