

SBC



PSB-602LF

Socket 775 New Intel®
Q965, supports Intel®
Core™ 2 Duo Processors

Features and Benefits:

- PICMG 1.0 Full size CPU card, supports Intel® Core™ 2 Duo, Intel® Celeron® D, Intel® Pentium® D and Intel® Pentium® 4 processors
- Equipped with Intel® Q965 Chipset with FSB 1066MHz
- Memory supports DDRII 800 SDRAM up to 4GB
- Applications such as gaming, medical, multimedia systems, digital image storage servers and more



Protech Systems Co., Ltd.

No. 24, Lane 365, Yang Goang Street, Nei Hu
District Taipei 114, Taiwan
TEL: +886-2-8751-1111 FAX: +886-2-8751-1199
E-mail: sales@protech.com.tw
<http://www.protech.com.tw>

Protech Technologies Inc.

950 Fee Ana St, Suite B Placentia, CA 92870
TEL: +1-714- 996-7200 FAX: +1-714- 996-7300
Sales: sales@protech-usa.net
<http://www.protech-usa.net>

Protech Japan Co., Ltd.

OSK Bldg, 6F, 6-25-14, Minami-ohi Shinagawa-ku,
Tokyo, 140-0013
TEL: +81-3-5753-8411 FAX: +81-3-3763-9282
E-mail: sam@protech-j.com
<http://www.protech-j.com>



ISO CERTIFIED
9001 14001

PSB-602LF

Socket 775 New Intel® Q965 Supports Intel® Core™ 2 Duo Processors

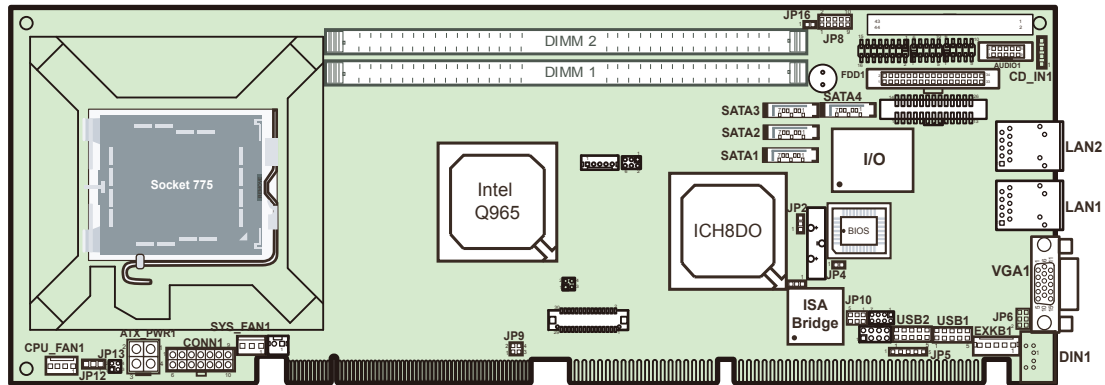

Specifications

System	
CPU Type	Intel® Celeron® D, Pentium® 4, Pentium® D, Core™ 2 Duo, LGA-775 processor
Chipset	Intel® Q965 + ICH8DO + FWH (FSB : 533/800/1066MHz)
DRAM	2 x 240-Pin DDR2-DIMM Socket (Supports DDR2 533/667/800MHz, up to 4GB)
BIOS	PhoenixAward PnP BIOS, with VGA BIOS
Watchdog	1~255 secs Watchdog timer selectable w / Reset / NMI
Power Supply	Supports ATX / AT Power
Power Requirement	+5V, +12V
Power Consumption	+5V : 3.2A / +12V : 10.45A
Dimension	338.5mm x 122mm (13.33" x 4.8")
Certificate	FCC / CE

I/O Chipset	
SATA Interface	4 x S-ATA connector
FDD Interface	1 x FDD connector with 34-pin Boxheader on board
IDE Interface	1 x 40-pin IDE (UDMA33/66/100)
Function BUS	1 x CF
Serial Port	2 x Serial ports, 16550 UARTs RS-232 x COM 1 for RS-232, COM 2 for RS-232/422/485
Parallel Port	1 x Parallel Port (SPP/EPP/ECP)
IrDA	1 (SIR)

Keyboard	Mini DIN connector or external connector
Mouse	Mini DIN connector (selectable w/KB) or Y-cable
LAN	LAN1/2: Marvell 88E8071, 1G BaseTxEthernet Supports Wake-on-LAN with ATX power
Audio	HD Codec, Realtek ALC262 with Line-in/Line-out/MIC
USB	4 x USB 2.0

Display	
Graphic	Built-in Intel® Q965, share system memory, Supports CRT, LVDS (LVDS transfer from SDVO)

Environment	
OperationTemp.	0°~60°C (32°~140°F)
Storage Temp.	-40°~85°C (-40°~185°F)
Humidity	Operation humidity 20~90%, Storage humidity 20~95%

Ordering Information	
PSB-602LF	PICMG 1.0 Intel® Core™ S775 Q965 w VGA / Audio / 2 x COM / 2 x LAN (GbE) / Raid / LVDS
PSB-602LF-E	PICMG 1.0 Intel® Core™ S775 Q965 w VGA / Audio / 2 x COM / 2 x LAN (GbE) / Raid

All of trademarks and brand names are the property of their owners. Trademark "Protech" is the property of Protech Systems Co., Ltd. All information contained in this document is subject to change without any prior notice. This catalog is copyrighted in Apr. 2010.